

USER MANUAL

MODEL:

VS-42H2

4K 4x2 HDMI Matrix Switcher



Contents

Introduction	1
Getting Started	1
Overview	2
Typical Applications	3
Defining VS-42H2 4K 4x2 HDMI Matrix Switcher	4
Mounting VS-42H2	6
Connecting VS-42H2	7
Connecting to VS-42H2 via Ethernet	8
Connecting the Remote Input Selection Switches	10
Connecting to VS-42H2 via RS-232	10
Operating and Controlling VS-42H2 via Front Panel Buttons	11
Locking and Unlocking Front Panel Buttons	11
Acquiring an EDID from an Output	11
Muting and Unmuting Output AV	12
Routing an Input to an Output	12
Configuring and Maintaining VS-42H2	13
Setting DIP-Switches	13
Resetting VS-42H2 to Factory Default Settings	14
Upgrading Firmware	14
Using Embedded Web Pages	15
Routing and Setting the Inputs and Outputs	16
Managing EDID	18
Setting Device Parameters	20
Upgrade the Firmware	22
Viewing the About Us Page	23
Technical Specifications	24
Default Communication Parameters	25
Default EDID	25
Protocol 3000	28
Understanding Protocol 3000	28
Protocol 3000 Commands	29
Result and Error Codes	35

Introduction

Welcome to Kramer Electronics! Since 1981, Kramer Electronics has been providing a world of unique, creative, and affordable solutions to the vast range of problems that confront the video, audio, presentation, and broadcasting professional on a daily basis. In recent years, we have redesigned and upgraded most of our line, making the best even better!

Getting Started

We recommend that you:

- Unpack the equipment carefully and save the original box and packaging materials for possible future shipment.
- Review the contents of this user manual.



Go to www.kramerav.com/downloads/VS-42H2 to check for up-to-date user manuals, application programs, and to check if firmware upgrades are available (where appropriate).

Achieving Best Performance

- Use only good quality connection cables (we recommend Kramer high-performance, high-resolution cables) to avoid interference, deterioration in signal quality due to poor matching, and elevated noise levels (often associated with low quality cables).
- Do not secure the cables in tight bundles or roll the slack into tight coils.
- Avoid interference from neighboring electrical appliances that may adversely influence signal quality.
- Position your Kramer **VS-42H2** away from moisture, excessive sunlight and dust.

Safety Instructions



Caution:

- This equipment is to be used only inside a building. It may only be connected to other equipment that is installed inside a building.
- For products with relay terminals and GPIO ports, please refer to the permitted rating for an external connection, located next to the terminal or in the User Manual.
- There are no operator serviceable parts inside the unit.



Warning:

- Use only the power cord that is supplied with the unit.
- To ensure continuous risk protection, replace fuses only according to the rating specified on the product label which located on the bottom of the unit.

Recycling Kramer Products

The Waste Electrical and Electronic Equipment (WEEE) Directive 2002/96/EC aims to reduce the amount of WEEE sent for disposal to landfill or incineration by requiring it to be collected and recycled. To comply with the WEEE Directive, Kramer Electronics has made arrangements with the European Advanced Recycling Network (EARN) and will cover any costs of treatment, recycling and recovery of waste Kramer Electronics branded equipment on arrival at the EARN facility. For details of Kramer's recycling arrangements in your particular country go to our recycling pages at www.kramerav.com/support/recycling.

Overview

Congratulations on purchasing your Kramer **VS-42H2 4K 4x2 HDMI Matrix Switcher**. **VS-42H2** is a high quality, 4x2 matrix switcher for HDMI™ signals that reclocks and equalizes the signals and routes any one of four HDMI, HDCP-compliant sources (selectable) to any or all outputs simultaneously.

VS-42H2 provides exceptional quality, advanced and user-friendly operation, and flexible control.

Exceptional Quality

- High-Performance AV Matrix – Switches 4 4K@60Hz (4:4:4) HDR HDMI HDCP-compliant signals to 2 18G 4K@60Hz (4:4:4) HDR HDMI HDCP-compliant outputs at up to 18G data rate. Signals are HDCP 2.2/1.4 compliant.
- Kramer Equalization & reKlocking™ Technology – Rebuilds the digital signal to travel longer distances.

Advanced and User-friendly Operation

- EDID Management – Individual EDID management per input. Captures and stores the EDID from a display device.
- Convenient Unit Control and Configuration – Local control via front panel, IR remote-control. Distance control via user-friendly embedded web pages via the Ethernet, Protocol 3000 and RS-232 serial commands.
- Cost-Effective Maintenance – Power status, IR and Input Selection indicators facilitate easy local maintenance and troubleshooting. Local and remote firmware upgrade via network connection through embedded web page interface which ensures lasting, field-proven deployment.
- Easy Installation – Half-19" size enables mounting in a 1U rack space with the recommended rack adapter.

Flexible Connectivity

- Flexible Content Protection – Selectable HDCP per input.

Typical Applications

VS-42H2 is ideal for the following typical applications:

- Conference Rooms.
- Education.
- Sports Bars.
- Restaurants.
- Casinos.
- Home Theaters.

Controlling your VS-42H2

Control your **VS-42H2** directly via the front panel push buttons (with on-screen menus), or:

- By RS-232 serial commands transmitted by a touch screen system, PC, or other serial controller.
- Remotely, from the infrared remote-control transmitter.
- Via the Ethernet using built-in user-friendly web pages.

Using the IR Transmitter

You can use the **RC-IR3** IR transmitter to control the machine via the built-in IR receiver on the front panel or, instead, via an optional external IR receiver. The external IR receiver can be located up to 15m away from the machine. This distance can be extended to up to 60m when used with three extension cables.

Before using the external IR receiver, be sure to arrange for your Kramer dealer to insert the internal IR connection cable with the 3.5mm connector that fits into the REMOTE IR opening on the rear panel. Connect the external IR receiver to the REMOTE IR 3.5mm connector.

Defining VS-42H2 4K 4x2 HDMI Matrix Switcher

This section defines VS-42H2.

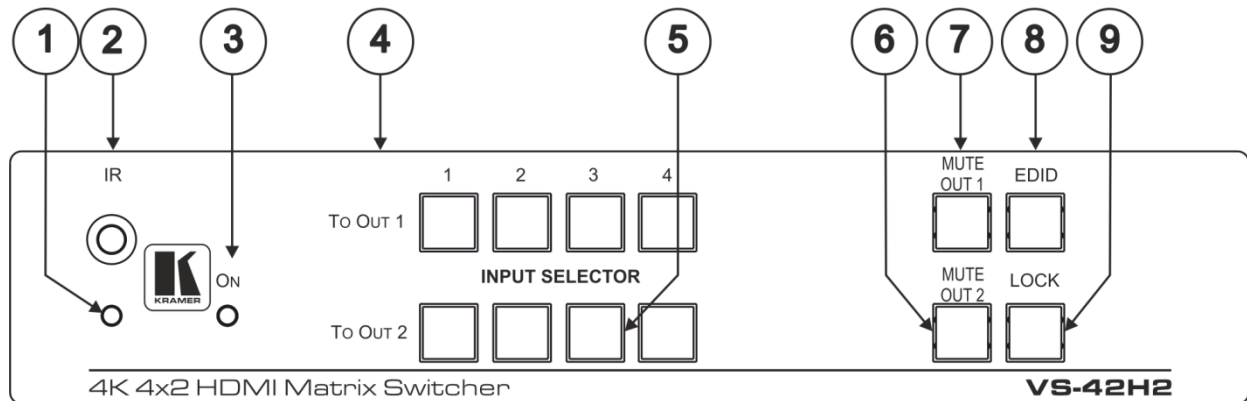

Figure 1: VS-42H2 4K 4x2 HDMI Matrix Switcher Front Panel

#	Feature	Function
①	IR LED	Lights yellow when receiving an IR signal.
②	IR Sensor	Receives signals from the infrared remote-control transmitter.
③	ON LED	Lights green when the device is powered on.
④	INPUT SELECTOR TO OUT 1, Buttons (1 to 4)	Press one of the four input buttons to switch it TO OUT 1.
⑤	INPUT SELECTOR TO OUT 2, Buttons (1 to 4)	Press one of the four input buttons to switch it TO OUT 2.
⑥	MUTE OUT 2 Button	Press to toggle mute of the OUT 2 signal.
⑦	MUTE OUT 1 Button	Press to toggle mute of the OUT 1 signal.
⑧	EDID Button	Press to capture the EDID (see Acquiring an EDID from an Output on page 11).
⑨	LOCK Button	Press and hold to lock the front panel buttons. Press and hold again to unlock.

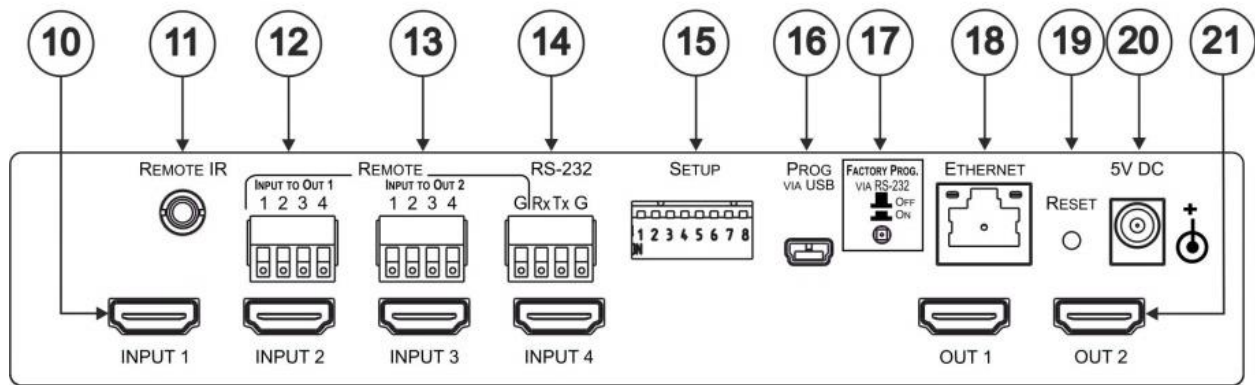

Figure 2: VS-42H2 4K 4x2 HDMI Matrix Switcher Rear Panel

#	Feature	Function
⑩	INPUT HDMI Input Connectors (1 to 4)	Connect to up to four HDMI sources.
⑪	REMOTE IR Opening	Connect to an external IR receiver for controlling the device via an IR remote-controller. Covered by a cap. The 3.5mm mini jack at the end of the internal IR connection cable fits into this opening. (see Using the IR Transmitter on page 3).
⑫	REMOTE INPUT TO OUT 1 4-pin Terminal Block + Ground	Connect to up to four remote, contact-closure input selection switches for Output 1 (see Connecting the Remote Input Selection Switches on page 10). i Use the left G pin on the RS-232 4-pin terminal block in conjunction with this terminal block.
⑬	REMOTE INPUT TO OUT 2 4-pin Terminal Block + Ground	Connect to up to four remote, contact-closure input selection switches for Output 2 (see Connecting the Remote Input Selection Switches on page 10). i Use the left G pin on the RS-232 4-pin terminal block in conjunction with this terminal block.
⑭	RS-232 4-pin Terminal Block	Connect to a PC/serial controller. i Use the three rightmost pins for the RS-232 control and the left ground pin for the two REMOTE INPUT TO OUT ⑫ and ⑬ terminal blocks
⑮	SETUP 8-way DIP-Switch	Sets the device configuration (see Setting DIP-Switches on page 13).
⑯	PROG VIA USB Connector	N/A
⑰	FACTORY PROG Switch	N/A
⑱	ETHERNET RJ-45 Connector	Connect to a PC via a LAN.
⑲	RESET Switch	Press while power-cycling the device to reset to factory default parameters.
⑳	5V DC Connector	Connect to the power adapter, center pin positive.
㉑	OUT 1 and OUT 2 HDMI Output Connectors	Connect to up to two HDMI acceptors.

Mounting VS-42H2

This section provides instructions for mounting **VS-42H2**. Before installing, verify that the environment is within the recommended range:



- Operation temperature – 0° to 40°C (32 to 104°F).
- Storage temperature – -40° to +70°C (-40 to +158°F).
- Humidity – 10% to 90%, RHL non-condensing.

**Caution:**

- Mount **VS-42H2** before connecting any cables or power.

**Warning:**

- Ensure that the environment (e.g., maximum ambient temperature & air flow) is compatible for the device.
- Avoid uneven mechanical loading.
- Appropriate consideration of equipment nameplate ratings should be used for avoiding overloading of the circuits.
- Reliable earthing of rack-mounted equipment should be maintained.
- Maximum mounting height for the device is 2 meters.

To mount the VS-42H2 in a rack:

Mount the unit in a rack using the recommended rack adapter (see www.kramerav.com/product/VS-42H2).

To mount the VS-42H2 on a table or shelf:

- Attach the rubber feet and place the unit on a flat surface.
- Fasten a bracket on each side of the unit and attach it to a flat surface.

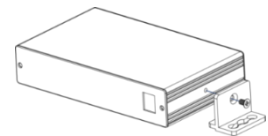

For more information go to www.kramerav.com/downloads/VS-42H2

Connecting VS-42H2



Always switch off the power to each device before connecting it to your VS-42H2. After connecting your VS-42H2, connect its power and then switch on the power to each device.

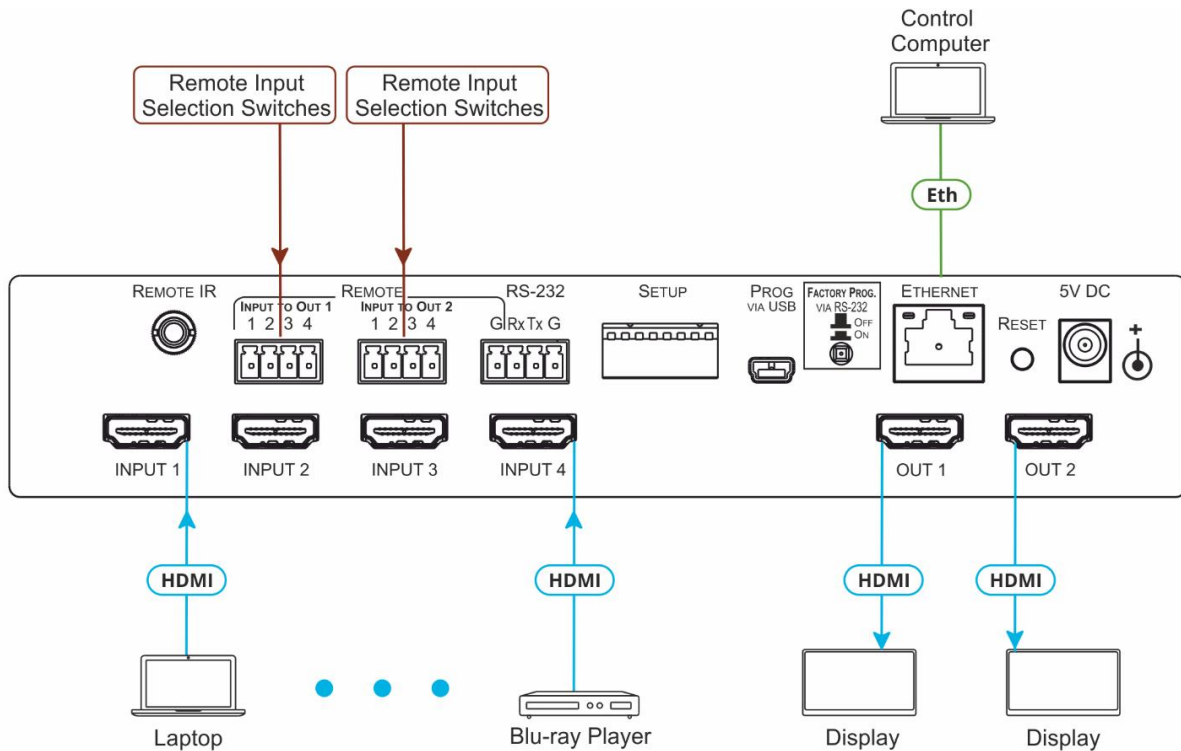

Figure 3: Connecting to the VS-42H2 Rear Panel

To connect the VS-42H2 as illustrated in the example in Figure 3:

1. Connect up to four HDMI sources, (for example, Blu-ray players) to the HDMI Input connectors ⑩.
2. Connect the two OUT HDMI connectors to up to two HDMI acceptors, (for example, LCD displays with built-in speakers).
3. If required, connect a PC/controller to the RS-232 port ⑭ (see [Connecting to VS-42H2 via RS-232](#) on page 10).
4. Connect the power adapter to the device and plug the power adapter into the mains electricity (not shown in [Figure 3](#)).
5. If required, acquire the EDID.

Connecting to VS-42H2 via Ethernet

You can connect to the VS-42H2 via Ethernet using either of the following methods:

- Directly to the PC using a crossover cable (see [Connecting the Ethernet Port Directly to a PC](#) on page 8).
- Via a network hub, switch, or router, using a straight-through cable (see [Connecting the Ethernet Port via a Network Hub or Switch](#) on page 9).



If you want to connect via a router and your IT system is based on IPv6, speak to your IT department for specific installation instructions.

Connecting the Ethernet Port Directly to a PC

You can connect the Ethernet port of the VS-42H2 directly to the Ethernet port on your PC using a crossover cable with RJ-45 connectors.



This type of connection is recommended for identifying the VS-42H2 with the factory configured default IP address.

After connecting the VS-42H2 to the Ethernet port, configure your PC as follows:

1. Click **Start > Control Panel > Network and Sharing Center**.
2. Click **Change Adapter Settings**.
3. Highlight the network adapter you want to use to connect to the device and click **Change settings of this connection**.

The Local Area Connection Properties window for the selected network adapter appears as shown in [Figure 4](#).

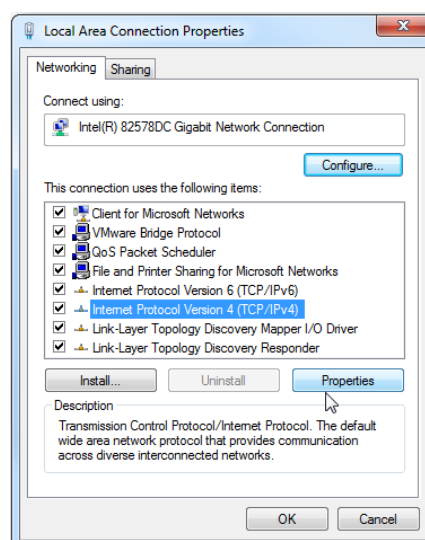

Figure 4: Local Area Connection Properties Window

4. Highlight **Internet Protocol Version 4 (TCP/IPv4)** by clicking on the item.
5. Click **Properties**.

The Internet Protocol Properties window appears as shown in [Figure 5](#).

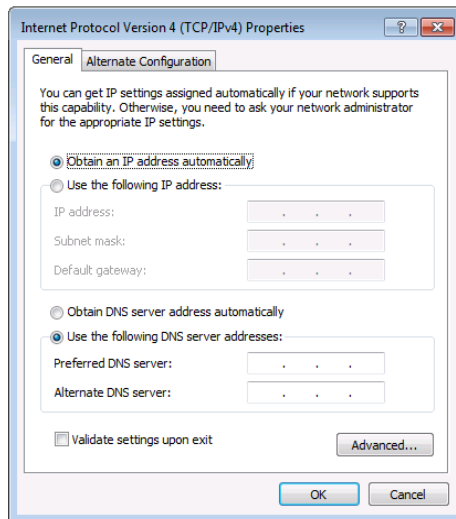

Figure 5: Internet Protocol Version 4 Properties Window

6. Select **Use the following IP Address** for static IP addressing and fill in the details as shown in [Figure 6](#).

For TCP/IPv4 you can use any IP address in the range 192.168.1.1 to 192.168.1.255 (excluding 192.168.1.39) that is provided by your IT department.

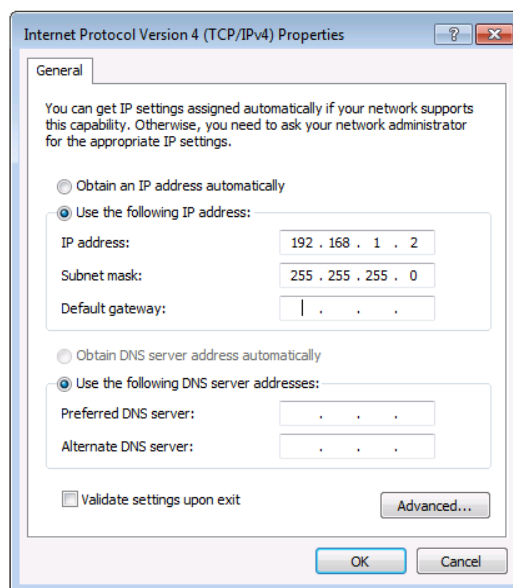

Figure 6: Internet Protocol Properties Window

7. Click **OK**.
8. Click **Close**.

Connecting the Ethernet Port via a Network Hub or Switch

You can connect the Ethernet port of the **VS-42H2** to the Ethernet port on a network hub or using a straight-through cable with RJ-45 connectors.

Connecting the Remote Input Selection Switches

These remote switches replicate the input selection buttons on the front panel of **VS-42H2**.

You can connect up to four remote, contact-closure switches per output to control the **VS-42H2** remotely.

[Figure 7](#) illustrates the wiring of the switch connections to the terminal block.

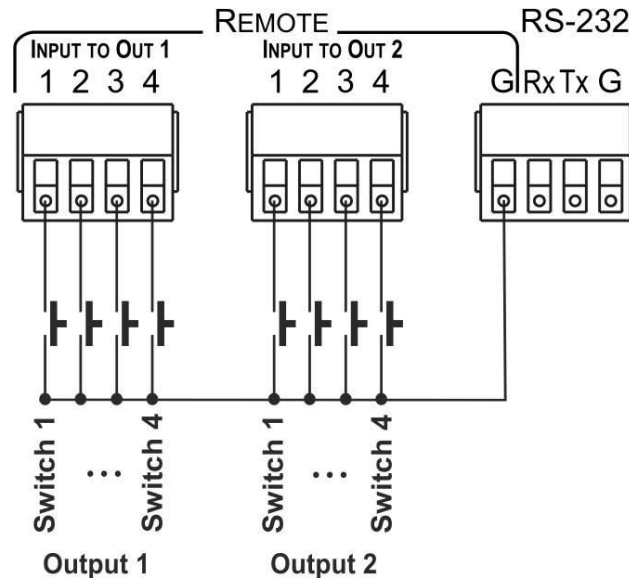

Figure 7: Remote Contact-closure Switch Connections

Connecting to VS-42H2 via RS-232

You can connect to the **VS-42H2** via an RS-232 4-pin Terminal Block (14) using, for example, a PC.

i The three rightmost pins are used for the RS-232 control and the left pin is used as Ground for the two REMOTE INPUT TO OUT (12) and (13) terminal blocks.

Connect the RS-232 terminal block on the rear panel of the **VS-42H2** to a PC/controller, as follows:

From the RS-232 9-pin D-sub serial port connect:

- Pin 2 to the TX pin on the **VS-42H2** RS-232 terminal block
- Pin 3 to the RX pin on the **VS-42H2** RS-232 terminal block
- Pin 5 to the G pin on the **VS-42H2** RS-232 terminal block

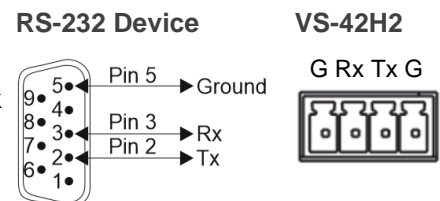

Operating and Controlling VS-42H2 via Front Panel Buttons

VS-42H2 front panel buttons allow you to do the following:

- [Locking and Unlocking Front Panel Buttons](#) on page [11](#).
- [Acquiring an EDID from an Output](#) on page [11](#).
- [Muting and Unmuting Output AV](#) on page [12](#).
- [Routing an Input to an Output](#) on page [12](#).

Locking and Unlocking Front Panel Buttons

You can toggle locking/unlocking the front panel buttons.

To lock front panel buttons:

- Press and hold **LOCK** (9) for about 3 seconds.
The front panel LOCK button lights and all the panel buttons are nonoperational.

To unlock front panel buttons:

- Press and hold **LOCK** (9) for about 3 seconds.
The front panel LOCK button no longer lights and all the panel buttons are operational.

Acquiring an EDID from an Output

You can acquire the EDID from OUT 1 or OUT 2 and copy it to any or all of the four inputs to be stored in non-volatile memory. You can also reset any or all the inputs to the default EDID.

To copy the EDID from Output 1 and/or Output 2 to one or more Inputs:

1. Press the **EDID** button (8) to enter the EDID setting mode.
The EDID button and all the INPUT SELECTOR buttons light.



If there is no button activity for 10 seconds, the device automatically exits the EDID setting mode to normal operation, the EDID button no longer lights and any changes made are lost.

2. From the TO OUT 1 (4) (top) row, press each of the Input buttons to deselect or select which inputs you want to copy the Output 1 EDID.
Each button press toggles the input button's light on or off.
3. From the TO OUT 2 (5) (bottom) row, press each of the Input buttons to deselect or select which inputs you want to copy the Output 2 EDID.
Each button press toggles the input button's light on or off.

4. Press **EDID** (8).

The EDID changes are saved.



The inputs that were routed to specific outputs will stay lit.

To copy the default EDID to one or more Inputs:

1. Press **EDID** (8) to enter the EDID setting mode.

The EDID button and all the INPUT SELECTOR buttons light.



Pressing the EDID button now applies the default EDID to all the inputs.

2. Deselect the pairs of input buttons to which you do not want to copy the default EDID by pressing both the **TO OUT 1** (4) and **TO OUT 2** (5) input buttons simultaneously.

Both top and bottom row Input LEDs turn off for the selected pair.

3. Press **EDID** (8).

The EDID changes are saved.

Muting and Unmuting Output AV

Use the MUTE button to mute/unmute an output audio and video.

To mute an output:

- Press **MUTE OUT 1** (7) or **MUTE OUT 2** (6).

The MUTE button lights, the inputs routed to the outputs flash and the output AV is muted.

To unmute an output:

- Press **MUTE OUT 1** (7) or **MUTE OUT 2** (6).

The MUTE button turns off, the inputs routed to the outputs stop flashing and the output AV is unmuted.

Routing an Input to an Output

Use the INPUT SELECTOR buttons to route a selected input to an output.

To route an input to output 1:

- From the **TO OUT 1** (4) (top) row, press an input button.

The selected input button lights and the input is routed to output 1.

To route an input to output 2:

- From the **TO OUT 2** (5) (bottom) row, press an input button.

The selected input button lights and the input is routed to output 2.

Configuring and Maintaining VS-42H2

Setting DIP-Switches

The eight DIP-switches ⁽¹⁵⁾ located on the back panel dictate the behavior of the VS-42H2.

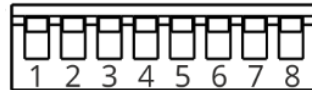

Figure 8: DIP-Switches

#	Feature	Description
1	Input 1 HDCP support	Off (up) – Input 1 does not support HDCP. On (down) – Input 1 is HDCP compliant.
2	Input 2 HDCP support	Off (up) – Input 2 does not support HDCP. On (down) – Input 2 is HDCP compliant.
3	Input 3 HDCP support	Off (up) – Input 3 does not support HDCP. On (down) – Input 3 is HDCP compliant.
4	Input 4 HDCP support	Off (up) – Input 4 does not support HDCP. On (down) – Input 4 is HDCP compliant.
5	Output 1 switching mode	Off (up) – Output 1: Manual switching. On (down) – Output 1: Automatic switching.
6	Output 1 switching type	Off (up) – Output 1: Last Connected mode (if DIP 5 is on). On (down) – Output 1: Priority mode (if DIP 5 is on).
7	Output 2 switching mode	Off (up) – Output 2: Manual switching. On (down) – Output 2: Automatic switching.
8	Output 2 switching type	Off (up) – Output 2: Last Connected mode (if DIP 7 is on). On (down) – Output 2: Priority mode (if DIP 7 is on).



The DIP-switch status is sampled when the device is reset. The unit must be powered off and on for the new settings to activate.

Resetting VS-42H2 to Factory Default Settings

To reset the device to factory default settings:

1. Unplug the device to power down VS-42H2.

VS-42H2 powers down.

2. While holding down the Reset button (19) on the rear panel using a sharp object, power on the device and wait a few seconds.

The device is reset to its factory settings.

Upgrading Firmware

VS-42H2 can be upgraded via Ethernet connection through embedded web page interface.

a

Using Embedded Web Pages

VS-42H2 enables you to configure settings via Ethernet using built-in, user-friendly web pages.



If a web page does not update correctly, clear your Web browser's cache.

1. Type the IP address of the device in the address bar of your internet browser (default = 192.168.1.39).

If security is enabled, the Login window appears.

Figure 9: Embedded Web Pages Login Window

2. Enter the Username (default = Admin) and Password (default = Admin) and click **Sign in**.

The default web page appears.

General Info	
Model name	VS-42H2
Firmware version	1.1.0001
Serial number	12180007800031
Web version	1.1.01

Figure 10: The General Info Page

The General Info page displays information related to the device and the Web page version.



You can also configure **VS-42H2** via Protocol 3000 commands (see [Protocol 3000 Commands](#) on page [29](#)).

VS-42H2 web pages enable performing the following:

- [Routing and Setting the Inputs and Outputs](#) on page [16](#).
- [Managing EDID](#) on page [18](#).
- [Setting Device Parameters](#) on page [20](#).
- [Upgrade the Firmware](#) on page [22](#).
- [Viewing the About Us Page](#) on page [23](#).

Routing and Setting the Inputs and Outputs

Use Routing page to perform the following actions:

- [Switching an Input to an Output](#) on page [16](#).
- [Muting and Unmuting Output AV](#) on page [17](#).
- [Locking and Unlocking Controls](#) on page [17](#).

Switching an Input to an Output

To switch an Input to an Output:

1. Click **Routing** on the Navigation List.

The Routing page appears.

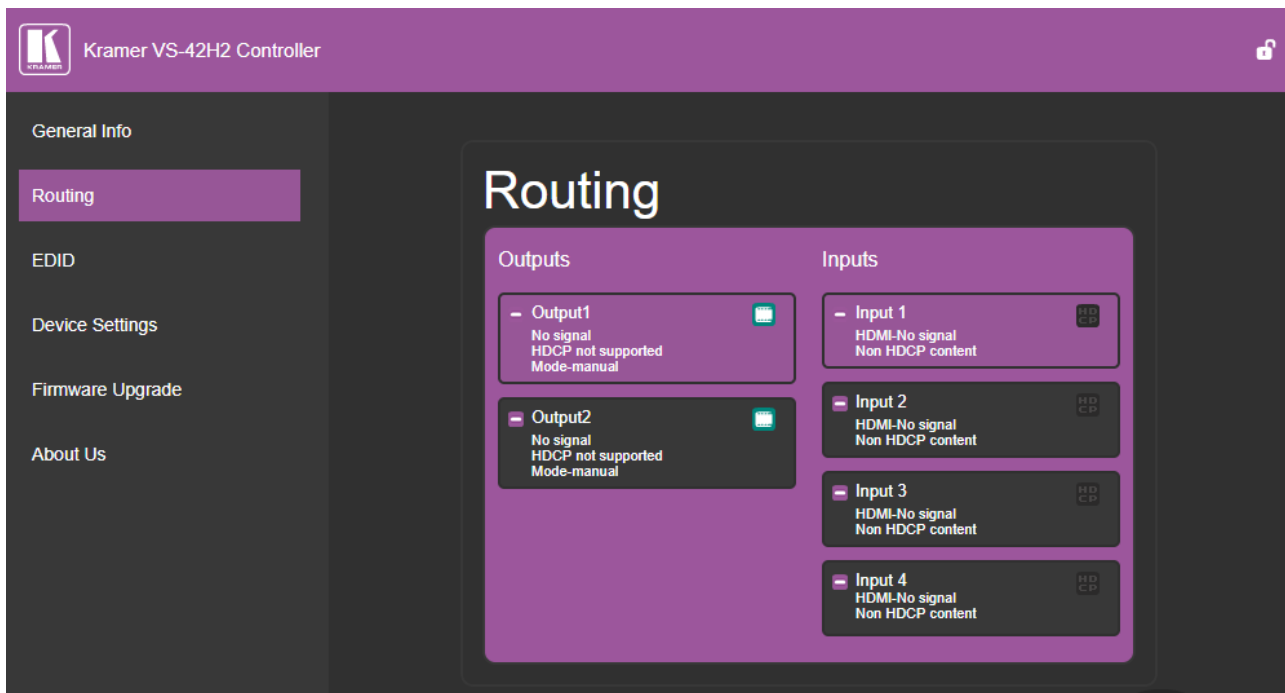

Figure 11: The Routing Page

2. Click **Output1** or **Output2**.

The button changes color to purple and the Output is selected.

3. Click an Input button.

The button changes color to purple and the input selected is routed to the output selected.

Muting and Unmuting Output AV

You can mute or unmute a selected output.

To mute output AV:

1. Click **Routing** on the Navigation List.

The Routing page appears ([Figure 11](#)).

2. Click  beside an output.

The selected output's audio and video are muted and the Mute icon changes to .

To unmute output AV:

1. Click **Routing** on the Navigation List.

The Routing page appears ([Figure 11](#)).

2. Click  beside an output.

The selected output's audio and video are no longer muted and the Mute icon changes to .

Locking and Unlocking Controls

To lock all the VS-42H2 controls:

1. Click **Routing**, **EDID**, or **Device Settings** on the Navigation List.

The navigated page appears.

2. Click the open lock icon  at the top right of the page.

The icon changes to a closed lock  and the **VS-42H2** controls are now locked.

To unlock all the VS-42H2 controls:

1. Click **Routing**, **EDID**, or **Device Settings** on the Navigation List.

The navigated page appears.

2. Click the closed lock icon  at the top right of the page.

The icon changes to an open lock icon  and the **VS-42H2** controls are unlocked.

Managing EDID

Use the EDID page to copy EDID data to one or more Inputs from an Output, Input, or from an EDID data file.

The EDID page enables performing the following functions:

- [Copying EDID Data from an Output or Input](#) on page [18](#).
- [Copying EDID Data from an EDID Data File](#) on page [19](#).



The display is not updated automatically when the status of an EDID changes on the device due to outputs being exchanged. Click Refresh to update the display.

Copying EDID Data from an Output or Input

To copy EDID data from an output or input to one or more inputs:

1. Click **EDID** on the Navigation List.

The EDID page appears.

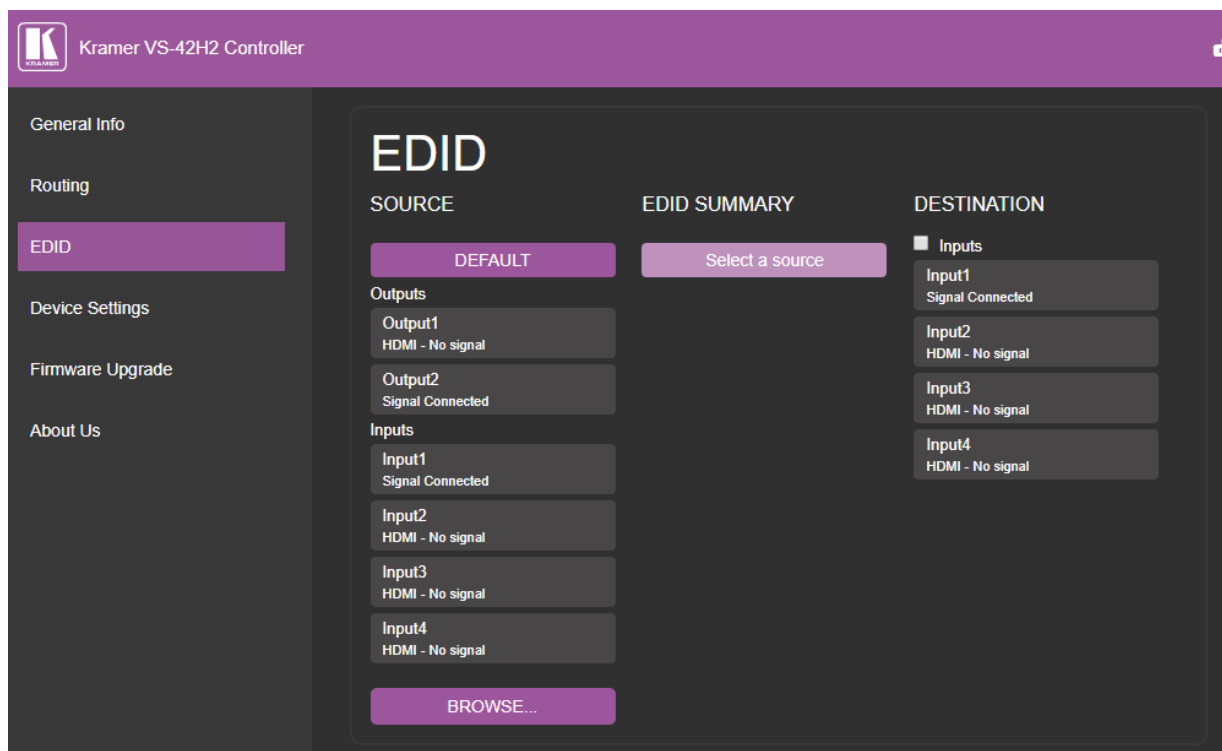

Figure 12: The EDID Page

2. Click the source button from which to copy the EDID (Output or Input).

The button changes color and the EDID summary information reflects the EDID data.

3. Click one or more destination inputs or select all inputs by checking the Inputs check-box.

All selected Input buttons change color and the EDID summary information reflects the Input selection(s).

4. Click the **Copy** button.

A success message is displayed and the EDID data are copied to the selected Input(s).

5. Click **OK**.

The message disappears.

Copying EDID Data from an EDID Data File

To copy EDID data to an input from an EDID data file:

1. Click **EDID** on the Navigation List.

The EDID page appears.

2. Click the **BROWSE** button.

The Windows Browser opens.

3. Select the required file and click **Open**.

The EDID summary information reflects the selection.

4. Click one or more destination Inputs.

All selected Input buttons change color and the EDID summary information reflects the Input selection(s).



You can check or uncheck the Inputs checkbox to select or deselect all 4 inputs.

5. Click the Copy button.

The “EDID was copied” success message is displayed and the EDID data are copied to the selected Input(s).

6. Click **OK**.

Setting Device Parameters

Use the Device Settings page to modify some communication parameters and view others.

The Device Settings page enables performing the following functions:

- [Modifying Serial or Ethernet Communication Parameters](#) on page 20.
- [Performing a Factory Reset](#) on page 21.

Modifying Serial or Ethernet Communication Parameters

To modify serial or Ethernet communication parameters:

1. Click **Device Settings** on the Navigation List.

The Device Settings page appears.

The screenshot shows the 'Device Settings' page for a Kramer VS-42H2 Controller. The page has a dark theme with purple accents. On the left is a navigation menu with options: General Info, Routing, EDID, Device Settings (highlighted), Firmware Upgrade, and About Us. The main content area is titled 'Device Settings' and contains several sections:

- Unit Info:** Unit name is 'KRAMER' with a 'set' button.
- RS-232:** Baud rate is '115200' with a dropdown arrow and a 'set' button.
- Ethernet:** DHCP is set to 'OFF' (with 'ON' also visible).
- IP address:** '192.168.001.039' with a 'set' button.
- UDP Port:** '50000' with a 'set' button.
- TCP Port:** '5000' with a 'set' button.
- Mask:** '255.255.000.000' with a 'set' button.
- Gateway:** '192.168.000.001' with a 'set' button.
- Mac:** '00-1D-56-04-8F-20'.
- Factory Reset:** A purple button labeled 'Factory Reset'.

Figure 13: The Device Setting Page

2. Adjust the parameters as required, either by entering the parameters directly or by using the drop-down list and click **set**.

The changes are saved.

Performing a Factory Reset

To reset the device to its factory default values:

1. Click **Device Settings** on the Navigation List.

The Device Settings page appears.

2. Click **Factory Reset**.

The following window appears:

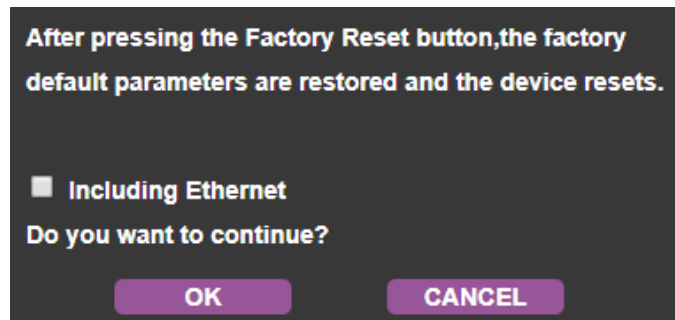

Figure 14: Factory Reset message

3. Choose whether to include resetting Ethernet parameters and click **OK**.

The device resets to its default parameters.

Upgrade the Firmware

The Firmware Upgrade page lets you perform a firmware upgrade from a firmware file.

Upgrading Firmware

To upgrade the firmware:

1. Click **Firmware Upgrade** on the Navigation List.

The Firmware Upgrade page appears.

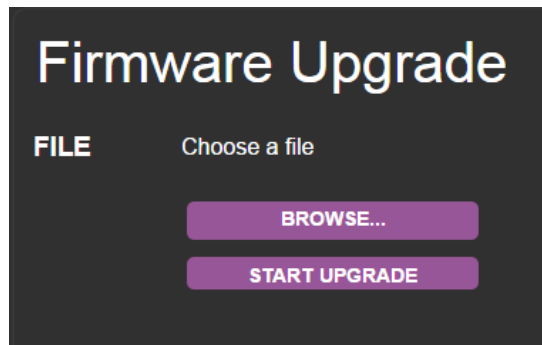

Figure 15: The Firmware Upgrade Page

2. Click the **BROWSE** button.

The Windows Browser opens.

3. Select the required file and click **Open**.

The firmware file name is displayed in the Firmware Upgrade page.

4. Click **START UPGRADE**.

The firmware file is loaded and a progress bar is displayed.



Do not interrupt the process or the **VS-42H2** may be damaged.

5. When the process is complete reboot the device.

The firmware is upgraded.

Viewing the About Us Page

The VS-42H2 About Us page displays the Web page version and Kramer Electronics Ltd company details.

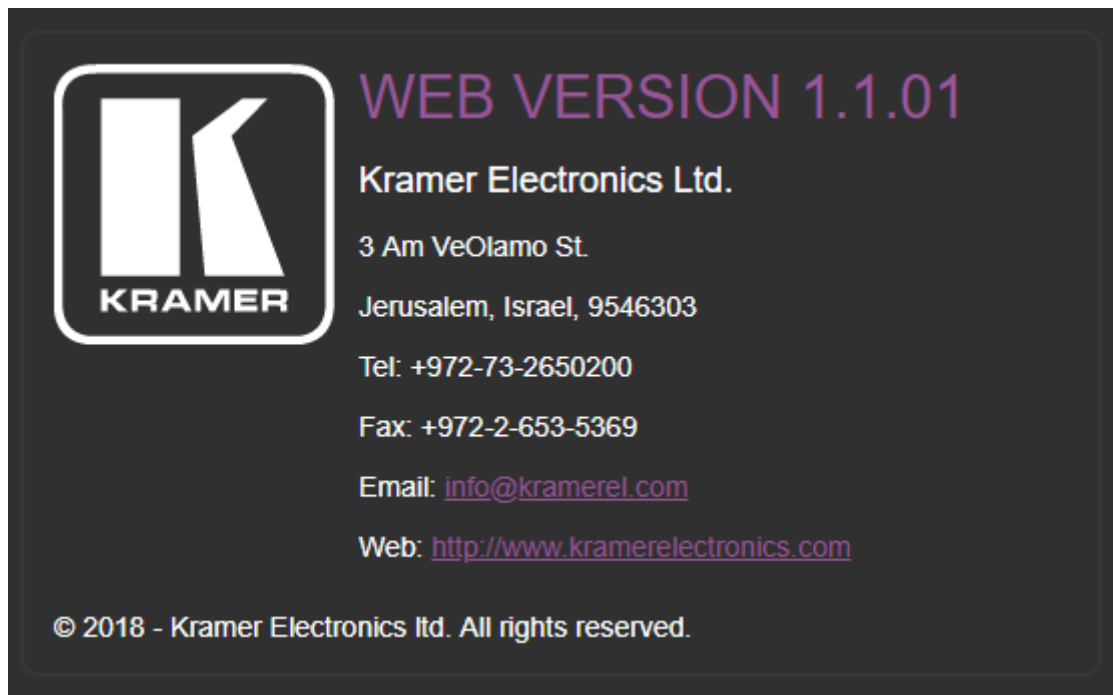

Figure 16: The About Us Page

Technical Specifications

Inputs	4 HDMI	On female HDMI connectors
Outputs	2 HDMI	On female HDMI connectors
Ports	Ethernet	On an RJ-45 female connector
	RS-232	On a 4-pin terminal block
	USB	On a mini USB connector
	8 Remote Selection Contact-Closure Switches	On 9 terminal block pins
Video	Max Bandwidth	18Gbps (6Gbps per graphic channel)
	Max Resolution	4K@60Hz (4:4:4)
	Compliance	HDCP 2.2/1.4
Controls	Rear Panel	DIP-switches
	Front Panel	Input selector
		Output mute
		EDID capture
Indication LEDs		Power LED
		IR
Power	Consumption	5V DC, 2.5A
	Source	5V DC, 4A
Environmental Conditions	Operating Temperature	0° to +40°C (32° to 104°F)
	Storage Temperature	-40° to +70°C (-40° to 158°F)
	Humidity	10% to 90%, RHL non-condensing
Regulatory Compliance	Safety	CE, UL
	Environmental	RoHs, WEEE
Enclosure	Size	Half 19" 1U
	Type	Aluminum
	Cooling	Convection ventilation
General	Net Dimensions (W, D, H)	21.5cm x 16.3cm x 4.4 cm (8.45" x 6.42" x 1.73")
	Shipping Dimensions (W, D, H)	35.1cm x 21.2cm x 7.2cm (13.82" x 8.35" x 2.83")
	Net Weight	1.0kg (2.1lbs) approx.
	Shipping Weight	1.6kg (3.5lbs) approx.
Accessories	Included	Power adapter and cord
		Rubber feet
	Optional	To achieve specified extension distances, use the recommended Kramer cables available at www.kramerav.com/product/VS-42H2
Specifications are subject to change without notice at www.kramerav.com		

Default Communication Parameters

RS-232	
Baud Rate:	115,200
Data Bits:	8
Stop Bits:	1
Parity:	None
Command Format:	ASCII
Ethernet	
To reset the IP settings to the factory reset values go to: Menu->Setup -> Factory Reset-> press Enter to confirm	
IP Address:	192.168.1.39
Subnet mask:	255.255.0.0
Gateway:	0.0.0.0
TCP Port #:	5000
UDP Port #:	50000
Default username:	Admin
Default password:	Admin

Default EDID

Monitor

Model name..... VS-42H2
 Manufacturer..... KMR
 Plug and Play ID..... KMR031D
 Serial number..... 49
 Manufacture date..... 2016, ISO week 19
 Filter driver..... None

EDID revision..... 1.3
 Input signal type..... Digital
 Color bit depth..... Undefined
 Display type..... Monochrome/grayscale
 Screen size..... 360 x 360 mm (20.0 in)
 Power management..... Standby, Suspend, Active off/sleep
 Extension blocs..... 1 (CEA-EXT)

 DDC/CI..... Not supported

Color characteristics

Default color space..... Non-sRGB
 Display gamma..... 2.40
 Red chromaticity..... Rx 0.611 - Ry 0.329
 Green chromaticity..... Gx 0.313 - Gy 0.559
 Blue chromaticity..... Bx 0.148 - By 0.131
 White point (default).... Wx 0.320 - Wy 0.336
 Additional descriptors... None

Timing characteristics

Horizontal scan range.... 15-136kHz
 Vertical scan range..... 23-61Hz
 Video bandwidth..... 600MHz
 CVT standard..... Not supported
 GTF standard..... Not supported
 Additional descriptors... None
 Preferred timing..... Yes
 Native/preferred timing.. 3840x2160p at 60Hz (16:9)
 Modeline..... "3840x2160" 594.000 3840 4016 4104 4400 2160 2168 2178 2250 +hsync +vsync
 Detailed timing #1..... 1920x1080p at 60Hz (16:9)
 Modeline..... "1920x1080" 148.500 1920 2008 2052 2200 1080 1084 1089 1125 +hsync +vsync

Standard timings supported

640 x 480p at 60Hz - IBM VGA
 640 x 480p at 72Hz - VESA
 640 x 480p at 75Hz - VESA
 800 x 600p at 56Hz - VESA
 800 x 600p at 60Hz - VESA
 800 x 600p at 72Hz - VESA
 800 x 600p at 75Hz - VESA

1024 x 768p at 60Hz - VESA
 1024 x 768p at 70Hz - VESA
 1024 x 768p at 75Hz - VESA
 1280 x 1024p at 75Hz - VESA
 1600 x 1200p at 60Hz - VESA STD
 1280 x 1024p at 60Hz - VESA STD
 1400 x 1050p at 60Hz - VESA STD
 1920 x 1080p at 60Hz - VESA STD
 640 x 480p at 85Hz - VESA STD
 800 x 600p at 85Hz - VESA STD
 1024 x 768p at 85Hz - VESA STD
 1280 x 1024p at 85Hz - VESA STD

EIA/CEA-861 Information

Revision number..... 3
 IT underscan..... Supported
 Basic audio..... Supported
 YCbCr 4:4:4..... Supported
 YCbCr 4:2:2..... Supported
 Native formats..... 0
 Detailed timing #1..... 1440x900p at 60Hz (16:10)
 Modeline..... "1440x900" 106.500 1440 1520 1672 1904 900 903 909 934 -hsync +vsync
 Detailed timing #2..... 1366x768p at 60Hz (16:9)
 Modeline..... "1366x768" 85.500 1366 1436 1579 1792 768 771 774 798 +hsync +vsync

CE video identifiers (VICs) - timing/formats supported

1920 x 1080p at 60Hz - HDTV (16:9, 1:1)
 1920 x 1080p at 50Hz - HDTV (16:9, 1:1)
 1280 x 720p at 60Hz - HDTV (16:9, 1:1)
 1280 x 720p at 50Hz - HDTV (16:9, 1:1)
 1920 x 1080i at 60Hz - HDTV (16:9, 1:1)
 1920 x 1080i at 50Hz - HDTV (16:9, 1:1)
 720 x 480p at 60Hz - EDTV (4:3, 8:9)
 720 x 576p at 50Hz - EDTV (4:3, 16:15)
 720 x 480i at 60Hz - Doublescan (4:3, 8:9)
 720 x 576i at 50Hz - Doublescan (4:3, 16:15)
 1920 x 1080p at 30Hz - HDTV (16:9, 1:1)
 1920 x 1080p at 25Hz - HDTV (16:9, 1:1)
 1920 x 1080p at 24Hz - HDTV (16:9, 1:1)
 1920 x 1080p at 24Hz - HDTV (16:9, 1:1)
 1920 x 1080p at 24Hz - HDTV (16:9, 1:1)
 1920 x 1080p at 24Hz - HDTV (16:9, 1:1)
 1920 x 1080p at 24Hz - HDTV (16:9, 1:1)
 1920 x 1080p at 24Hz - HDTV (16:9, 1:1)
 NB: NTSC refresh rate = (Hz*1000)/1001

CE audio data (formats supported)

LPCM 2-channel, 16/20/24 bit depths at 32/44/48 kHz
 AC-3 6-channel, 640k max. bit rate at 32/44/48 kHz
 DTS 7-channel, 1536k max. bit rate at 32/44/48 kHz
 DD+ 8-channel at 32/44/48 kHz
 DTS-HD 8-channel, 16-bit at 32/44/48 kHz
 DVD-A 8-channel at 32/44/48 kHz
 LPCM 6-channel, 16/20/24 bit depths at 32/44/48 kHz
 LPCM 8-channel, 16/20/24 bit depths at 32/44/48 kHz

CE speaker allocation data

Channel configuration.... 7.1
 Front left/right..... Yes
 Front LFE..... Yes
 Front center..... Yes
 Rear left/right..... Yes
 Rear center..... No
 Front left/right center.. No
 Rear left/right center... Yes
 Rear LFE..... No

CE vendor specific data (VSDB)

IEEE registration number. 0x000C03
 CEC physical address..... 1.0.0.0
 Supports AI (ACP, ISRC).. No
 Supports 48bpp..... No
 Supports 36bpp..... Yes
 Supports 30bpp..... Yes
 Supports YCbCr 4:4:4..... Yes
 Supports dual-link DVI... No
 Maximum TMDS clock..... 300MHz
 Audio/video latency (p).. n/a
 Audio/video latency (i).. n/a
 HDMI video capabilities.. Yes
 EDID screen size..... No additional info
 3D formats supported..... Not supported
 Data payload..... 030C001000383C20008001020304

CE vendor specific data (VSDB)
IEEE registration number. 0xC45DD8
CEC physical address..... 0.1.7.8
Supports AI (ACP, ISRC).. Yes
Supports 48bpp..... No
Supports 36bpp..... No
Supports 30bpp..... No
Supports YCbCr 4:4:4..... No
Supports dual-link DVI... No
Maximum TMDS clock..... 35MHz

Reserved video related data
Data payload..... 0F000003

Report information
Date generated..... 12/03/2018
Software revision..... 2.70.0.989
Data source..... Real-time 0x0071
Operating system..... 6.1.7601.2.Service Pack 1

Raw data
00,FF,FF,FF,FF,FF,FF,00,2D,B2,1D,03,31,00,00,00,13,1A,01,03,80,24,24,8C,E2,90,20,9C,54,50,8F,26,
21,52,56,2F,CF,00,A9,40,81,80,90,40,D1,C0,31,59,45,59,61,59,81,99,08,E8,00,30,F2,70,5A,80,B0,58,
8A,00,BA,88,21,00,00,1E,02,3A,80,18,71,38,2D,40,58,2C,45,00,BA,88,21,00,00,1E,00,00,00,FC,00,56,
53,2D,34,32,48,32,0A,20,20,20,20,0A,00,00,FD,00,17,3D,0F,88,3C,00,0A,20,20,20,20,20,01,C4,
02,03,50,F0,52,10,1F,04,13,05,14,02,11,06,15,22,21,20,5D,5E,5F,60,61,38,09,07,07,15,07,50,3E,07,
C0,57,07,00,5F,07,01,67,07,00,0D,07,07,0F,07,07,83,4F,00,00,6E,03,0C,00,10,00,38,3C,20,00,80,01,
02,03,04,67,D8,5D,C4,01,78,80,07,E4,0F,00,00,03,9A,29,A0,D0,51,84,22,30,50,98,36,00,10,0A,00,00,
00,1C,66,21,56,AA,51,00,1E,30,46,8F,33,00,10,09,00,00,00,1E,28,3C,80,00,00,00,00,00,00,00,A9

Protocol 3000

Kramer devices can be operated using Kramer Protocol 3000 commands sent via serial or Ethernet ports.

Understanding Protocol 3000

Protocol 3000 commands are a sequence of ASCII letters, structured according to the following.

- **Command format:**

Prefix	Command Name	Constant (Space)	Parameter(s)	Suffix
#	Command	-	Parameter	<CR>

- **Feedback format:**

Prefix	Device ID	Constant	Command Name	Parameter(s)	Suffix
~	nn	@	Command	Parameter	<CR><LF>

- **Command parameters** – Multiple parameters must be separated by a comma (,). In addition, multiple parameters can be grouped as a single parameter using brackets ([and]).
- **Command chain separator character** – Multiple commands can be chained in the same string. Each command is delimited by a pipe character (|).
- **Parameters attributes** – Parameters may contain multiple attributes. Attributes are indicated with pointy brackets (<...>) and must be separated by a period (.).

The command framing varies according to how you interface with the VS-42H2. The following figure displays how the # command is framed using terminal communication software (such as Hercules):

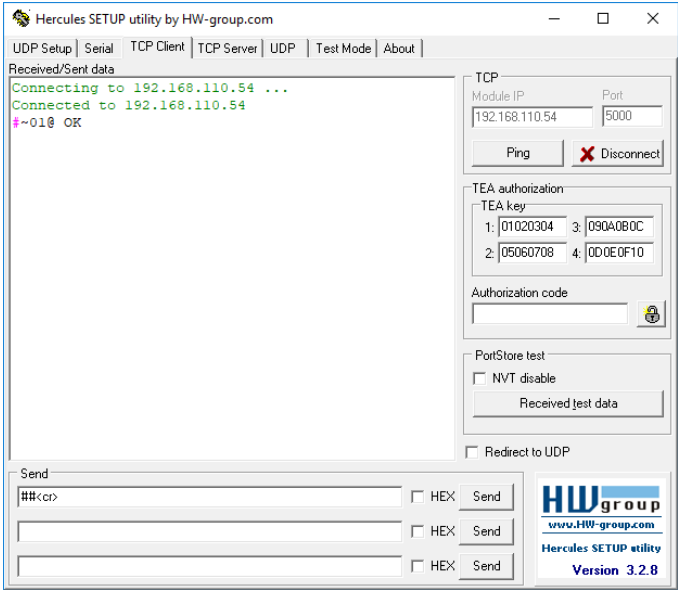











Protocol 3000 Commands

Function	Description	Syntax	Parameters/Attributes	Example
#	<p>Protocol handshaking.</p> <p>i Validates the Protocol 3000 connection and gets the machine number.</p> <p>Step-in master products use this command to identify the availability of a device.</p>	COMMAND #<CR> FEEDBACK ~nn@_ok<CR><LF>		#<CR>
BAUD	<p>Set protocol serial port baud rate.</p> <p>i The new defined baud rate is stored in the EEPROM and used when powering up.</p> <p>Default baud rate is 115200 (on factory reset).</p> <p>Only works with devices supporting this command (if ERR 002 is returned, the default baud rate is used).</p>	COMMAND #BAUD_baud_rate<CR> FEEDBACK ~nn@BAUD_baud_rate<CR><LF> <p>Option 1: ~nn@BAUD_current_baud_rate<CR><LF></p> <p>Option 2: ~nn@BAUD_baud_rate1, baud_rate2, . . <CR><LF></p>	baud_rate – 9600 / 115200 / else - new baud rate to set current_baud_rate – 9600 / 115200 / else - current protocol serial port baud rate baud_param – 0 - get the list of supported baud rates baud_rate1, baud_rate2, ... – List of supported baud rates	Set the baud rate to 9600: #BAUD_9600<CR>
BAUD?	<p>Get protocol serial port baud rate. (Option 1 - for current baud rate. Option 2 - for list of supported baud rates).</p> <p>i The new defined baud rate is stored in the EEPROM and used when powering up.</p> <p>Default baud rate is 115200 (on factory reset).</p> <p>Only works with devices supporting this command (if ERR 002 is returned, the default baud rate is used).</p>	COMMAND #BAUD?_<CR> #BAUD?_baud_param<CR> FEEDBACK ~nn@BAUD_baud_rate<CR><LF> <p>Option 1: ~nn@BAUD_current_baud_rate<CR><LF></p> <p>Option 2: ~nn@BAUD_baud_rate1, baud_rate2, . . <CR><LF></p>	baud_rate – 9600 / 115200 / else - new baud rate to set current_baud_rate – 9600 / 115200 / else - current protocol serial port baud rate baud_param – 0 - get the list of supported baud rates baud_rate1, – Baud_rate2, ... - list of supported baud rates	Get protocol serial port baud rate: #BAUD?_<CR>
BUILD-DATE?	<p>Get device build date.</p>	COMMAND #BUILD-DATE?_<CR> FEEDBACK ~nn@BUILD-DATE_date, time<CR><LF>	date – Format: YYYY/MM/DD where YYYY = Year MM = Month DD = Day time – Format: hh:mm:ss where hh = hours mm = minutes ss = seconds	Get the device build date: #BUILD-DATE?<CR>
CPEDID	<p>Copy EDID data from the output to the input EEPROM.</p> <p>i Destination bitmap size depends on device properties (for 64 inputs it is a 64-bit word).</p> <p>Example: bitmap 0x0013 means inputs 1,2 and 5 are loaded with the new EDID.</p> <p>In certain products Safe_mode is an optional parameter. See the HELP command for its availability.</p>	COMMAND #CPEDID_edid_io, src_id, edid_io, dest_bitmap<CR> or #CPEDID_edid_io, src_id, edid_io, dest_bitmap, safe_mode<CR> FEEDBACK ~nn@CPEDID_edid_io, src_id, edid_io, dest_bitmap<CR><LF> ~nn@CPEDID_edid_io, src_id, edid_io, dest_bitmap, safe_mode<CR><LF>	edid_io – EDID source type (usually output) 0 – Input 1 – Output 2 – Default EDID 3 – Custom EDID src_id – Number of chosen source stage 0 – Default EDID source 1 – Output 1 2 – Output 2 edid_io – EDID destination type (usually input) 0 – Input 1 – Output 2 – Default EDID 3 – Custom EDID dest_bitmap – Bitmap representing destination IDs. Format: XXXX..X, where X is hex digit. The binary form of every hex digit represents corresponding destinations. 0 – indicates that EDID data is not copied to this destination. 1 – indicates that EDID data is copied to this destination. safe_mode – Safe mode 0 – device accepts the EDID as is without trying to adjust 1 – device tries to adjust the EDID (default value if no parameter is sent)	Copy the EDID data from the Output 1 (EDID source) to the Input: #CPEDID_1, 1, 0, 0x1<CR> Copy the EDID data from the default EDID source to the Input: #CPEDID_2, 0, 0, 0x1<CR>

Function	Description	Syntax	Parameters/Attributes	Example
DEF-RES?	<p>Get custom defined video resolution.</p> <p>i If a requested custom resolution is not defined, yet is in the device, it returns ERRSP003 (out of range).</p> <p>Only indexes 100-104 are valid for custom defined resolution.</p> <p>In Get command when sending:</p> <p>index 0 - device replies with detailed info of native resolution.</p> <p>index 255 - device replies with detailed info of current resolution.</p>	<p>COMMAND</p> <pre>#DEF-RES?_table_id,io_mode,in_index<CR></pre> <p>FEEDBACK</p> <pre>~nn@DEF-RES_table_id,width,height,htotal,vtotal,hsyncw,hsyncbackporch,vsyncw,vsyncbackporch,framerate,interlaced<CR><LF></pre>	<p>table_id – Index in resolution table</p> <p>If a requested custom resolution is not defined, yet is in the device, it returns ERRSP003 (out of range)</p> <p>Only indexes 100-104 are valid for custom defined resolution</p> <p>In Get command when sending:</p> <p>index 0 - device replies with detailed info of native resolution</p> <p>index 255 - device replies with detailed info of current resolution</p> <p>custom – Resolution parameters - by name (self-explanatory), numeric value</p> <p>interlaced – Interlaced/progressive according to On/Off ("ON"- 1, "OFF" - P)</p> <p>io_mode – Input/Output</p> <p>0 – Input</p> <p>1 – Output</p> <p>in_index – Number that indicates the specific input: 1 to 4</p>	<p>Get custom defined video resolution:</p> <pre>#DEF-RES?_255,0,1<CR></pre>
DISPLAY?	<p>Get output HPD status.</p>	<p>COMMAND</p> <pre>#DISPLAY?_out_index<CR></pre> <p>FEEDBACK</p> <pre>~nn@DISPLAY_out_index,status<CR><LF></pre>	<p>out_index – Number that indicates the specific output: 1 or 2</p> <p>status – HPD status according to signal validation</p> <p>0 – Signal or sink is not valid</p> <p>1 – Signal or sink is valid</p> <p>2 – Sink and EDID is valid</p>	<p>Get the output HPD status of Output 1:</p> <pre>#DISPLAY?_1<CR></pre>
ETH-PORT	<p>Set Ethernet port protocol.</p> <p>i If the port number you enter is already in use, an error is returned.</p> <p>The port number must be within the following range: 0-(2¹⁶-1).</p>	<p>COMMAND</p> <pre>#ETH-PORT_port_type,port_id<CR></pre> <p>FEEDBACK</p> <pre>~nn@ETH-PORT_port_type,port_id<CR><LF></pre>	<p>port_type – TCP/UDP</p> <p>port_id – TCP/UDP port number (0 – 65535)</p>	<p>Set the Ethernet port protocol for TCP to port 12457:</p> <pre>#ETH-PORT_0,12457<CR></pre>
ETH-PORT?	<p>Get Ethernet port protocol.</p>	<p>COMMAND</p> <pre>#ETH-PORT?_port_type<CR></pre> <p>FEEDBACK</p> <pre>~nn@ETH-PORT_port_type,port_id<CR><LF></pre>	<p>port_type – TCP/UDP</p> <p>TCP</p> <p>UDP</p> <p>port_id – TCP / UDP port number (0 – 65535)</p>	<p>Get the Ethernet port protocol:</p> <pre>#ETH-PORT?_UDP<CR></pre>
FACTORY	<p>Reset device to factory default configuration.</p> <p>i This command deletes all user data from the device. The deletion can take some time.</p> <p>Your device may require powering off and powering on for the changes to take effect.</p>	<p>COMMAND</p> <pre>#FACTORY<CR></pre> <p>FEEDBACK</p> <pre>~nn@FACTORY_ok<CR><LF></pre>		<p>Reset the device to factory default configuration:</p> <pre>#FACTORY<CR></pre>
GEDID	<p>Get EDID support on certain input/output.</p> <p>i For old devices that do not support this command, ~nn@ERR 002<CR><LF> is received.</p>	<p>COMMAND</p> <pre>#GEDID_io_mode,in_index<CR></pre> <p>FEEDBACK</p> <pre>~nn@GEDID_io_mode,in_index,size<CR><LF></pre>	<p>io_mode – Input/Output</p> <p>0 – Input</p> <p>1 – Output</p> <p>2 – Default EDID</p> <p>3 – Custom EDID</p> <p>in_index – Number that indicates the specific input: 1 to 4</p> <p>size – Size of data to be sent from device, 0 means no EDID support</p>	<p>Get EDID support information for input 1:</p> <pre>#GEDID_001<CR></pre>
HDCP-MOD	<p>Set HDCP mode.</p> <p>i Set HDCP working mode on the device input:</p> <p>HDCP supported - HDCP_ON [default].</p> <p>HDCP not supported - HDCP OFF.</p> <p>HDCP support changes following detected sink - MIRROR OUTPUT.</p> <p>When you define 3 as the mode, the HDCP status is defined according to the connected output in the following priority: OUT 1, OUT 2. If the connected display on OUT 2 supports HDCP, but OUT 1 does not, then HDCP is defined as not supported. If OUT 1 is not connected, then HDCP is defined by OUT 2.</p>	<p>COMMAND</p> <pre>#HDCP-MOD_in_index,mode<CR></pre> <p>FEEDBACK</p> <pre>~nn@HDCP-MOD_in_index,mode<CR><LF></pre>	<p>in_index – Number that indicates the specific input: 1 to 4</p> <p>mode – HDCP mode:</p> <p>0 – HDCP Off</p> <p>3 – HDCP defined according to the connected output</p>	<p>Set the input HDCP-MODE of IN 1 to Off:</p> <pre>#HDCP-MOD_1,0<CR></pre>

Function	Description	Syntax	Parameters/Attributes	Example										
HDCP-MOD?	Get HDCP mode. ① Set HDCP working mode on the device input: HDCP supported - HDCP_ON [default]. HDCP not supported - HDCP OFF. HDCP support changes following detected sink - MIRROR OUTPUT.	COMMAND #HDCP-MOD?_in_index<CR> FEEDBACK ~nn@HDCP-MOD_in_index,mode<CR><LF>	in_index – Number that indicates the specific input: 1 to 4 mode – HDCP mode: 0 – HDCP Off 3 – HDCP defined according to the connected output	Get the input HDCP-MODE of IN 1 HDMI: #HDCP-MOD?_1<CR>										
HDCP-STAT?	Get HDCP signal status. ① io_mode =1 – get the HDCP signal status of the sink device connected to the specified output. io_mode =0 – get the HDCP signal status of the source device connected to the specified input.	COMMAND #HDCP-STAT?_io_mode, in_index<CR> FEEDBACK ~nn@HDCP-STAT_io_mode, in_index, status<CR><LF>	io_mode – Input/Output 0 – Input 1 – Output in_index – Number that indicates the specific input: 1 to 4 status – Signal encryption status - valid values On/Off 0 – HDCP Off 1 – HDCP On	Get the output HDCP-STATUS of IN 1: #HDCP-STAT?_0,1<CR>										
HELP	Get command list or help for specific command.	COMMAND #HELP<CR> #HELP_cmd_name<CR> FEEDBACK 1..ulti-line: ~nn@Device_cmd_name, cmd_name.<CR><LF> To get help for command use: HELP (COMMAND_NAME)<CR><LF> ~nn@HELP_cmd_name:<CR><LF> description<CR><LF> USAGE: usage<CR><LF>	cmd_name – Name of a specific command	Get the command list: #HELP<CR> To get help for AV-SW-TIMEOUT: HELP_av-sw-timeout<CR>										
LDEDID	Write EDID data from external application to device. ① When the unit receives the LDEDID command it replies with READY and enters the special EDID packet wait mode. In this mode the unit can receive only packets and not regular protocol commands. If the unit does not receive correct packets for 30 seconds or is interrupted for more than 30 seconds before receiving all packets, it sends timeout error ~nn@LDEDID_err01<CR><LF> and returns to the regular protocol mode. If the unit received data that is not a correct packet, it sends the corresponding error and returns to the regular protocol mode.	COMMAND Multi-step syntax FEEDBACK Step 1: #LDEDID_edid_io, dest_bitmask, edid_size, safe_mode<CR> Response 1: ~nn@LDEDID_edid_io, dest_bitmask, edid_size, safe_mode_ready<CR><LF> or ~nn@LDEDID_errnn<CR><LF> Step 2: If ready was received, end EDID_DATA Response 2: ~nn@LDEDID_edid_io, dest_bitmask, edid_size, safe_mode_ok<CR><LF> or ~nn@LDEDID_errnn<CR><LF>	edid_io – EDID destination type (usually input) 0 – Input 1 – Output 2 – Default EDID 3 – Custom EDID dest_bitmask – Bitmap representing destination IDs. Format: 0x*****, where * is ASCII presentation of hex digit. The binary presentation of this number is a bit mask for destinations. Setting '1' means EDID data has to be copied to this destination edid_size – EDID data size safe_mode – Safe mode 0 – Device accepts the EDID as is without trying to adjust 1 – Device tries to adjust the EDID edid_data – Data in protocol packets Using the Packet Protocol Send a command: LDRV, LOAD, IROUT, LDEDID Receive Ready or ERR### If Ready: a. Send a packet, b. Receive OK on the last packet, c. Receive OK for the command Packet structure: Packet ID (1, 2, 3...) (2 bytes in length) Length (data length + 2 for CRC) – (2 bytes in length) Data (data length -2 bytes) CRC – 2 bytes <table border="1"><tr><td>01</td><td>02</td><td>03</td><td>04</td><td>05</td></tr><tr><td>Packet ID</td><td>Length</td><td>Data</td><td colspan="2">CRC</td></tr></table> 5. Response: ~nnnn_ok<CR><LF> (Where NNNN is the received packet ID in ASCII hex digits.)	01	02	03	04	05	Packet ID	Length	Data	CRC		Write the EDID data from an external application to the HDMI In 1 input without adjustment attempts: #LDEDID_0, 0x1, 2340, 0<CR> > Write the EDID data from an external application to HDMI In 1 and PC In inputs with adjustment attempts: #LDEDID_0, 0x5, 2340, 1<CR> >
01	02	03	04	05										
Packet ID	Length	Data	CRC											
LOCK-FP	Lock the front panel. ① In NT-52N, this command includes the PortNumber (1-2) parameter.	COMMAND #LOCK-FP_lock/unlock<CR> FEEDBACK ~nn@LOCK-FP_lock/unlock<CR><LF>	lock/unlock – On/Off 0 – Off unlocks EDID 1 – On locks EDID	Unlock front panel: #LOCK-FP_0<CR>										
LOCK-FP?	Get the front panel lock state. ① In NT-52N, this command includes the PortNumber (1-2) parameter.	COMMAND #LOCK-FP?_<CR> FEEDBACK ~nn@LOCK-FP_lock/unlock<CR><LF>	lock/unlock – On/Off 0 – Off unlocks EDID 1 – On locks EDID	Get the front panel lock state: #LOCK-FP?<CR>										
MODEL?	Get device model. ① This command identifies equipment connected to VS-42H2 and notifies of identity changes to the connected equipment. The Matrix saves this data in memory to answer REMOTE-INFO requests.	COMMAND #MODEL?_<CR> FEEDBACK ~nn@MODEL_model_name<CR><LF>	model_name – String of up to 19 printable ASCII chars	Get the device model: #MODEL?_<CR>										

Function	Description	Syntax	Parameters/Attributes	Example
MTX-MODE	<p>LEGACY COMMAND. Set auto-switch mode.</p> <p>i Not recommended for new devices.</p>	<p>COMMAND #MTX-MODE_out_id,connection_mode<CR></p> <p>FEEDBACK ~nn@MTX-MODE_out_id,connection_mode<CR><LF></p>	<p>out_id – 1 to number of system outputs connection_mode – Connection mode 0 – manual 1 – auto priority 2 – auto last connected</p>	<p>Set output to last connected: #MTX-MODE_1,2<CR></p>
MTX-MODE?	<p>LEGACY COMMAND. Get auto-switch mode.</p> <p>i Not recommended for new devices.</p>	<p>COMMAND #MTX-MODE?_out_id<CR></p> <p>FEEDBACK ~nn@MTX-MODE_out_id,connection_mode<CR><LF></p>	<p>out_id – 1 to number of system outputs connection_mode – Connection mode 0 – manual 1 – auto priority 2 – auto last connected</p>	<p>Get auto-switch mode: #MTX-MODE?_2<CR></p>
NAME	<p>Set machine (DNS) name.</p> <p>i The machine name is not the same as the model name. The machine name is used to identify a specific machine or a network in use (with DNS feature on).</p>	<p>COMMAND #NAME_machine_name<CR></p> <p>FEEDBACK ~nn@NAME_machine_name<CR><LF></p>	<p>machine_name – String of up to 15 alpha-numeric chars (can include hyphen, not at the beginning or end)</p>	<p>Set the DNS name of the device to room-442: #NAME_room-442<CR></p>
NAME?	<p>Get machine (DNS) name.</p> <p>i The machine name is not the same as the model name. The machine name is used to identify a specific machine or a network in use (with DNS feature on).</p>	<p>COMMAND #NAME?_<CR></p> <p>FEEDBACK ~nn@NAME_machine_name<CR><LF></p>	<p>machine_name – String of up to 15 alpha-numeric chars (can include hyphen, not at the beginning or end)</p>	<p>Get the DNS name of the device: #NAME?_<CR></p>
NAME-RST	<p>Reset machine (DNS) name to factory default.</p> <p>i Factory default of machine (DNS) name is "KRAMER_" + 4 last digits of device serial number.</p>	<p>COMMAND #NAME-RST<CR></p> <p>FEEDBACK ~nn@NAME-RST_ok<CR><LF></p>		<p>Reset the machine name (S/N last digits are 0102): #NAME-RST_kramer_0102<CR></p>
NET-DHCP	<p>Set DHCP mode.</p> <p>i Only 1 is relevant for the mode value. To disable DHCP, the user must configure a static IP address for the device.</p> <p>Connecting Ethernet to devices with DHCP may take more time in some networks.</p> <p>To connect with a randomly assigned IP by DHCP, specify the device DNS name (if available) using the NAME command. You can also get an assigned IP by direct connection to USB or RS-232 protocol port, if available.</p> <p>For proper settings consult your network administrator.</p> <p>i For Backward compatibility, the id parameter can be omitted. In this case, the Network ID, by default, is 0, which is the Ethernet control port.</p>	<p>COMMAND #NET-DHCP_netw_id,dhcp_state<CR></p> <p>FEEDBACK ~nn@NET-DHCP_netw_id,dhcp_state<CR><LF></p>	<p>netw_id – Network ID—the device network interface (if there are more than one). Counting is 0 based, meaning the control port is '0', additional ports are 1,2,3.... dhcp_state – 1 – Try to use DHCP. (If unavailable, use the IP address set by the factory or the net-ip command).</p>	<p>Enable DHCP mode for port 1, if available: #NET-DHCP_1,1<CR></p>
NET-DHCP?	<p>Get DHCP mode.</p>	<p>COMMAND #NET-DHCP?_<CR></p> <p>FEEDBACK ~nn@NET-DHCP_dhcp_mode<CR><LF></p>	<p>dhcp_mode – 0 – Do not use DHCP. Use the IP set by the factory or using the net-ip or net-config command. 1 – Try to use DHCP. If unavailable, use the IP set by the factory or using the net-ip or net-config command.</p>	<p>Get DHCP mode for port 1: #NET-DHCP?_1<CR></p>
NET-GATE	<p>Set gateway IP.</p> <p>i A network gateway connects the device via another network and maybe over the Internet. Be careful of security issues. For proper settings consult your network administrator.</p>	<p>COMMAND #NET-GATE_ip_address<CR></p> <p>FEEDBACK ~nn@NET-GATE_ip_address<CR><LF></p>	<p>ip_address – Format: xxx.xxx.xxx.xxx</p>	<p>Set the gateway IP address to 192.168.0.1: #NET-GATE_192.168.000.001<CR></p>
NET-GATE?	<p>Get gateway IP.</p> <p>i A network gateway connects the device via another network and maybe over the Internet. Be aware of security problems.</p>	<p>COMMAND #NET-GATE?_<CR></p> <p>FEEDBACK ~nn@NET-GATE_ip_address<CR><LF></p>	<p>ip_address – Format: xxx.xxx.xxx.xxx</p>	<p>Get the gateway IP address: #NET-GATE?_<CR></p>

Function	Description	Syntax	Parameters/Attributes	Example
NET-IP	Set IP address.  For proper settings consult your network administrator.	COMMAND #NET-IP_ip_address<CR> FEEDBACK ~nn@NET-IP_ip_address<CR><LF>	ip_address – Format: xxx.xxx.xxx.xxx	Set the IP address to 192.168.1.39: #NET-IP_192.168.001.039<CR>
NET-IP?	Get IP address.	COMMAND #NET-IP?_<CR> FEEDBACK ~nn@NET-IP_ip_address<CR><LF>	ip_address – Format: xxx.xxx.xxx.xxx	Get the IP address: #NET-IP?_<CR>
NET-MAC?	Get MAC address.  For backward compatibility, the id parameter can be omitted. In this case, the Network ID, by default, is 0, which is the Ethernet control port.	COMMAND #NET-MAC?_id<CR> FEEDBACK ~nn@NET-MAC_id,mac_address<CR><LF>	id – Network ID—the device network interface (if there are more than one). Counting is 0 based, meaning the control port is '0', additional ports are 1,2,3.... mac_address – Unique MAC address. Format: XX-XX-XX-XX-XX-XX where X is hex digit	#NET-MAC?_id<CR>
NET-MASK	Set subnet mask.  For proper settings consult your network administrator.	COMMAND #NET-MASK_net_mask<CR> FEEDBACK ~nn@NET-MASK_net_mask<CR><LF>	net_mask – Format: xxx.xxx.xxx.xxx	Set the subnet mask to 255.255.0.0: #NET-MASK_255.255.000.000<CR>
NET-MASK?	Get subnet mask.	COMMAND #NET-MASK?_<CR> FEEDBACK ~nn@NET-MASK_net_mask<CR><LF>	net_mask – Format: xxx.xxx.xxx.xxx	Get the subnet mask: #NET-MASK?_<CR>
PASS	Set password for login level.  The default password is an empty string.	COMMAND #PASS_login_level,password<CR> FEEDBACK ~nn@PASS_login_level,password<CR><LF>	login_level – Level of login to set (End User or Administrator). password – Password for the login_level. Up to 15 printable ASCII chars	Set the password for the Admin protocol permission level to 33333: #PASS_admin,33333<CR>
PASS?	Get password for login level.  The default password is an empty string.	COMMAND #PASS?_login_level<CR> FEEDBACK ~nn@PASS_login_level,password<CR><LF>	login_level – Level of login to set (End User or Administrator). password – Password for the login_level. Up to 15 printable ASCII chars	Get the password for the Admin protocol permission level: #PASS?_admin<CR>
PRIO	Set input priority.  The PRIO max value may vary for different devices.	COMMAND #PRIO_in_index,priority_value<CR> FEEDBACK ~nn@PRIO_in_index,priority_value<CR><LF>	in_index – Number that indicates the specific input: 1 to 4 priority_value – Assigned priority (1...max priority)	Set input priority #PRIO_1,4<CR>
PRIO?	Get input priority.  The PRIO max value may vary for different devices.	COMMAND #PRIO?_in_index<CR> FEEDBACK ~nn@PRIO_in_index,priority_value<CR><LF>	in_index – Number that indicates the specific input: 1 to 4 priority_value – Assigned priority (1...max priority)	PRIO
PROT-VER?	Get device protocol version.	COMMAND #PROT-VER?_<CR> FEEDBACK ~nn@PROT-VER_3000:version<CR><LF>	version – XX.XX where X is a decimal digit	Get the device protocol version: #PROT-VER?_<CR>
RESET	Reset device.  To avoid locking the port due to a USB bug in Windows, disconnect USB connections immediately after running this command. If the port was locked, disconnect and reconnect the cable to reopen the port.	COMMAND #RESET<CR> FEEDBACK ~nn@RESET_ok<CR><LF>		Reset the device: #RESET<CR>
ROUTE	Set layer routing.  This command replaces all other routing commands.	COMMAND #ROUTE_layer_type,out_index,in_index<CR> FEEDBACK ~nn@ROUTE_layer_type,out_index<CR><LF>	layer_type Layer Enumeration 1 – Video out_index 1 – OUT 1 HDMI 2 – OUT 2 HDMI * – ALL in_index – Source id 1 – IN 1 HDMI 2 – IN 2 HDMI 3 – IN 3 HDMI 4 – IN 4 HDMI	Route video IN 2 HDBT to video OUT 8 HDBT: #ROUTE_1,8,2<CR>
ROUTE?	Get layer routing.  This command replaces all other routing commands.	COMMAND #ROUTE?_layer_type,out_index<CR> FEEDBACK ~nn@ROUTE_layer_type,out_index,in_index<CR><LF>	layer_type Layer Enumeration 1 – Video out_index 1 – OUT 1 HDMI 2 – OUT 2 HDMI * – ALL in_index – Source id 1 – IN 1 HDMI 2 – IN 2 HDMI 3 – IN 3 HDMI 4 – IN 4 HDMI	Get the layer routing: #ROUTE?_layer,dest<CR>
SIGNAL?	Get input signal status.	COMMAND #SIGNAL?_in_index<CR> FEEDBACK ~nn@SIGNAL_in_index,status<CR><LF>	in_index – Number that indicates the specific input: 1 to 4 status – Signal status according to signal validation: 0 – Off 1 – On	Get the input signal lock status of IN 1: #SIGNAL?_1<CR>

Function	Description	Syntax	Parameters/Attributes	Example
SN?	Get device serial number.	COMMAND #SN?_<CR> FEEDBACK ~nn@SN_serial_num<CR><LF>	serial_num – 14 decimal digits, factory assigned	Get the device serial number: #SN?_<CR>
VERSION?	Get firmware version number.	COMMAND #VERSION?_<CR> FEEDBACK ~nn@VERSION_firmware_version<CR><LF>	firmware_version – XX.XX.XXXX where the digit groups are: major.minor.build version	Get the device firmware version number: #VERSION?_<CR>
VID	LEGACY COMMAND. Set video switch state. ⓘ The SET command is for remote input switching on Step-in clients (essentially via by the Web). This is a legacy command. New Step-in modules support the ROUTE command.	COMMAND #VID_in_id>out_id<CR> FEEDBACK ~nn@VID_in_id>out_id<CR><LF>	in_id – Indicates the ID of the input: 1 to 4 > – Connection character between in and out parameters out_id – Output number (1 or 2) * for all outputs	Switch IN 1 to OUT 3: #VID_1>3<CR>
VID?	LEGACY COMMAND. Get video switch state. ⓘ The GET command identifies input switching on Step-in clients. This is a legacy command. New Step-in modules support the ROUTE command.	COMMAND #VID?_out_id<CR> FEEDBACK ~nn@VID?_out_id<CR><LF>	in_id – Indicates the ID of the input: 1 to 4 > – Connection character between in and out parameters out_id – Output number (1 or 2) * for all outputs	Get video switch state: #VID?_2<CR>
VMUTE	Set enable/disable video on output. ⓘ Video mute parameter 2 (blank picture) is not supported.	COMMAND #VMUTE_out_index, flag<CR> FEEDBACK ~nn@VMUTE_out_index, flag<CR><LF>	out_index – Number that indicates the specific output: 1 or 2 flag – Video Mute 0 – Video enabled 1 – Video disabled 2 – Blank picture	Disable the video output on OUT 2: #VMUTE_2, 0<CR>
VMUTE?	Get video on output status. ⓘ Video mute parameter 2 (blank picture) is not supported.	COMMAND #VMUTE?_out_index<CR> FEEDBACK ~nn@VMUTE_out_index, flag<CR><LF>	out_index – Number that indicates the specific output: 1 or 2 flag – Video Mute 0 – Video enabled 1 – Video disabled 2 – Blank picture	Get video on output status: #VMUTE?_2<CR>

Result and Error Codes

Syntax

In case of an error, the device responds with an error message. The error message syntax:

- **~NN@ERR XXX<CR><LF>** – when general error, no specific command
- **~NN@CMD ERR XXX<CR><LF>** – for specific command
- **NN** – machine number of device, default = 01
- **XXX** – error code

Error Codes

Error Name	Error Code	Description
P3K_NO_ERROR	0	No error
ERR_PROTOCOL_SYNTAX	1	Protocol syntax
ERR_COMMAND_NOT_AVAILABLE	2	Command not available
ERR_PARAMETER_OUT_OF_RANGE	3	Parameter out of range
ERR_UNAUTHORIZED_ACCESS	4	Unauthorized access
ERR_INTERNAL_FW_ERROR	5	Internal FW error
ERR_BUSY	6	Protocol busy
ERR_WRONG_CRC	7	Wrong CRC
ERR_TIMEDOUT	8	Timeout
ERR_RESERVED	9	(Reserved)
ERR_FW_NOT_ENOUGH_SPACE	10	Not enough space for data (firmware, FPGA...)
ERR_FS_NOT_ENOUGH_SPACE	11	Not enough space – file system
ERR_FS_FILE_NOT_EXISTS	12	File does not exist
ERR_FS_FILE_CANT_CREATED	13	File can't be created
ERR_FS_FILE_CANT_OPEN	14	File can't open
ERR_FEATURE_NOT_SUPPORTED	15	Feature is not supported
ERR_RESERVED_2	16	(Reserved)
ERR_RESERVED_3	17	(Reserved)
ERR_RESERVED_4	18	(Reserved)
ERR_RESERVED_5	19	(Reserved)
ERR_RESERVED_6	20	(Reserved)
ERR_PACKET_CRC	21	Packet CRC error
ERR_PACKET_MISSED	22	Packet number isn't expected (missing packet)
ERR_PACKET_SIZE	23	Packet size is wrong
ERR_RESERVED_7	24	(Reserved)
ERR_RESERVED_8	25	(Reserved)
ERR_RESERVED_9	26	(Reserved)
ERR_RESERVED_10	27	(Reserved)
ERR_RESERVED_11	28	(Reserved)
ERR_RESERVED_12	29	(Reserved)
ERR_EDID_CORRUPTED	30	EDID corrupted
ERR_NON_LISTED	31	Device specific errors
ERR_SAME_CRC	32	File has the same CRC – no changed
ERR_WRONG_MODE	33	Wrong operation mode
ERR_NOT_CONFIGURED	34	Device/chip was not initialized

The warranty obligations of Kramer Electronics Inc. ("Kramer Electronics") for this product are limited to the terms set forth below:

What is Covered

This limited warranty covers defects in materials and workmanship in this product.

What is Not Covered

This limited warranty does not cover any damage, deterioration or malfunction resulting from any alteration, modification, improper or unreasonable use or maintenance, misuse, abuse, accident, neglect, exposure to excess moisture, fire, improper packing and shipping (such claims must be presented to the carrier), lightning, power surges, or other acts of nature. This limited warranty does not cover any damage, deterioration or malfunction resulting from the installation or removal of this product from any installation, any unauthorized tampering with this product, any repairs attempted by anyone unauthorized by Kramer Electronics to make such repairs, or any other cause which does not relate directly to a defect in materials and/or workmanship of this product. This limited warranty does not cover cartons, equipment enclosures, cables or accessories used in conjunction with this product.

Without limiting any other exclusion herein, Kramer Electronics does not warrant that the product covered hereby, including, without limitation, the technology and/or integrated circuit(s) included in the product, will not become obsolete or that such items are or will remain compatible with any other product or technology with which the product may be used.

How Long this Coverage Lasts

The standard limited warranty for Kramer products is seven (7) years from the date of original purchase, with the following exceptions:

1. All Kramer VIA hardware products are covered by a standard three (3) year warranty for the VIA hardware and a standard three (3) year warranty for firmware and software updates; all Kramer VIA accessories, adapters, tags, and dongles are covered by a standard one (1) year warranty.
2. Kramer fiber optic cables, adapter-size fiber optic extenders, pluggable optical modules, active cables, cable retractors, ring mounted adapters, portable power chargers, Kramer speakers, and Kramer touch panels are all covered by a standard one (1) year warranty.
3. All Kramer Cobra products, all Kramer Calibre products, all Kramer Minicom digital signage products, all HighSecLabs products, all streaming, and all wireless products are covered by a standard three (3) year warranty.
4. All Sierra Video MultiViewers are covered by a standard five (5) year warranty.
5. Sierra switchers & control panels are covered by a standard seven (7) year warranty (excluding power supplies and fans that are covered for three (3) years).
6. K-Touch software is covered by a standard one (1) year warranty for software updates.
7. All Kramer passive cables are covered by a ten (10) year warranty.

Who is Covered

Only the original purchaser of this product is covered under this limited warranty. This limited warranty is not transferable to subsequent purchasers or owners of this product.

What Kramer Electronics Will Do

Kramer Electronics will, at its sole option, provide one of the following three remedies to whatever extent it shall deem necessary to satisfy a proper claim under this limited warranty:

1. Elect to repair or facilitate the repair of any defective parts within a reasonable period of time, free of any charge for the necessary parts and labor to complete the repair and restore this product to its proper operating condition. Kramer Electronics will also pay the shipping costs necessary to return this product once the repair is complete.
2. Replace this product with a direct replacement or with a similar product deemed by Kramer Electronics to perform substantially the same function as the original product. If a direct or similar replacement product is supplied, the original product's end warranty date remains unchanged and is transferred to the replacement product.
3. Issue a refund of the original purchase price less depreciation to be determined based on the age of the product at the time remedy is sought under this limited warranty.

What Kramer Electronics Will Not Do Under This Limited Warranty

If this product is returned to Kramer Electronics or the authorized dealer from which it was purchased or any other party authorized to repair Kramer Electronics products, this product must be insured during shipment, with the insurance and shipping charges prepaid by you. If this product is returned uninsured, you assume all risks of loss or damage during shipment. Kramer Electronics will not be responsible for any costs related to the removal or re-installation of this product from or into any installation. Kramer Electronics will not be responsible for any costs related to any setting up this product, any adjustment of user controls or any programming required for a specific installation of this product.

How to Obtain a Remedy Under This Limited Warranty

To obtain a remedy under this limited warranty, you must contact either the authorized Kramer Electronics reseller from whom you purchased this product or the Kramer Electronics office nearest you. For a list of authorized Kramer Electronics resellers and/or Kramer Electronics authorized service providers, visit our web site at www.kramerav.com or contact the Kramer Electronics office nearest you.

In order to pursue any remedy under this limited warranty, you must possess an original, dated receipt as proof of purchase from an authorized Kramer Electronics reseller. If this product is returned under this limited warranty, a return authorization number, obtained from Kramer Electronics, will be required (RMA number). You may also be directed to an authorized reseller or a person authorized by Kramer Electronics to repair the product.

If it is decided that this product should be returned directly to Kramer Electronics, this product should be properly packed, preferably in the original carton, for shipping. Cartons not bearing a return authorization number will be refused.

Limitation of Liability

THE MAXIMUM LIABILITY OF KRAMER ELECTRONICS UNDER THIS LIMITED WARRANTY SHALL NOT EXCEED THE ACTUAL PURCHASE PRICE PAID FOR THE PRODUCT. TO THE MAXIMUM EXTENT PERMITTED BY LAW, KRAMER ELECTRONICS IS NOT RESPONSIBLE FOR DIRECT, SPECIAL, INCIDENTAL OR CONSEQUENTIAL DAMAGES RESULTING FROM ANY BREACH OF WARRANTY OR CONDITION, OR UNDER ANY OTHER LEGAL THEORY. Some countries, districts or states do not allow the exclusion or limitation of relief, special, incidental, consequential or indirect damages, or the limitation of liability to specified amounts, so the above limitations or exclusions may not apply to you.

Exclusive Remedy

TO THE MAXIMUM EXTENT PERMITTED BY LAW, THIS LIMITED WARRANTY AND THE REMEDIES SET FORTH ABOVE ARE EXCLUSIVE AND IN LIEU OF ALL OTHER WARRANTIES, REMEDIES AND CONDITIONS, WHETHER ORAL OR WRITTEN, EXPRESS OR IMPLIED. TO THE MAXIMUM EXTENT PERMITTED BY LAW, KRAMER ELECTRONICS SPECIFICALLY DISCLAIMS ANY AND ALL IMPLIED WARRANTIES, INCLUDING, WITHOUT LIMITATION, WARRANTIES OF MERCHANTABILITY AND FITNESS FOR A PARTICULAR PURPOSE. IF KRAMER ELECTRONICS CANNOT LAWFULLY DISCLAIM OR EXCLUDE IMPLIED WARRANTIES UNDER APPLICABLE LAW, THEN ALL IMPLIED WARRANTIES COVERING THIS PRODUCT, INCLUDING WARRANTIES OF MERCHANTABILITY AND FITNESS FOR A PARTICULAR PURPOSE, SHALL APPLY TO THIS PRODUCT AS PROVIDED UNDER APPLICABLE LAW. IF ANY PRODUCT TO WHICH THIS LIMITED WARRANTY APPLIES IS A "CONSUMER PRODUCT" UNDER THE MAGNUSON-MOSS WARRANTY ACT (15 U.S.C.A. §2301, ET SEQ.) OR OTHER APPLICABLE LAW, THE FOREGOING DISCLAIMER OF IMPLIED WARRANTIES SHALL NOT APPLY TO YOU, AND ALL IMPLIED WARRANTIES ON THIS PRODUCT, INCLUDING WARRANTIES OF MERCHANTABILITY AND FITNESS FOR THE PARTICULAR PURPOSE, SHALL APPLY AS PROVIDED UNDER APPLICABLE LAW.

Other Conditions

This limited warranty gives you specific legal rights, and you may have other rights which vary from country to country or state to state.

This limited warranty is void if (i) the label bearing the serial number of this product has been removed or defaced, (ii) the product is not distributed by Kramer Electronics or (iii) this product is not purchased from an authorized Kramer Electronics reseller. If you are unsure whether a reseller is an authorized Kramer Electronics reseller, visit our web site at www.kramerav.com or contact a Kramer Electronics office from the list at the end of this document.

Your rights under this limited warranty are not diminished if you do not complete and return the product registration form or complete and submit the online product registration form. Kramer Electronics thanks you for purchasing a Kramer Electronics product. We hope it will give you years of satisfaction.



SAFETY WARNING

Disconnect the unit from the power supply before opening and servicing

For the latest information on our products and a list of Kramer distributors, visit our website where updates to this user manual may be found.

We welcome your questions, comments, and feedback.

The terms HDMI, HDMI High-Definition Multimedia Interface, and the HDMI Logo are trademarks or registered trademarks of HDMI Licensing Administrator, Inc. All brand names, product names, and trademarks are the property of their respective owners.