

USER MANUAL

MODEL:

VS-88H2A

4K HDMI 8x8 Matrix Switcher

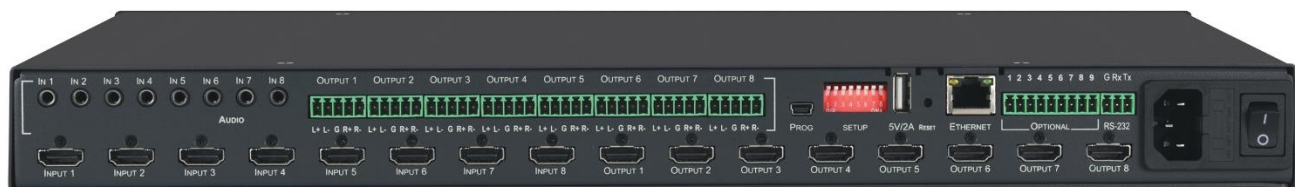

Contents

Introduction	1
Getting Started	1
Overview	2
Typical Applications	4
Defining VS-88H2A 4K HDMI 8x8 Matrix Switcher	5
Mounting VS-88H2A	7
Connecting VS-88H2A	8
Connecting Output to a Balanced/Unbalanced Stereo Audio Acceptor	9
Connecting to VS-88H2A via RS-232	9
Operating VS-88H2A via Front Panel Buttons	10
Routing Signals	11
Muting/Unmuting an Output	16
Routing a Pattern to the Output	17
Operating in ARC Mode	18
Storing and Recalling a Setup	23
Setting Switching Mode	24
Setting Switching Speed	24
Setting HDCP	24
Copying EDID	25
Operating via Ethernet	26
Using Embedded Web Pages	29
Switching and Setting Ports	30
Changing Device Settings and Upgrading Firmware	38
Managing Web Page Security	40
Setting the Timeout	44
Setting Switching Modes	45
Setting Step-in Devices	47
Managing EDID	49
Viewing About Us Page	55
Upgrading Firmware	56
Technical Specifications	57
Default Communication Parameters	58
Input or Output Resolutions	59
Default Parameters	60
Default EDID	61
Protocol 3000	64
Understanding Protocol 3000	64
Protocol 3000 Commands	65
Result and Error Codes	80

Introduction

Welcome to Kramer Electronics! Since 1981, Kramer Electronics has been providing a world of unique, creative, and affordable solutions to the vast range of problems that confront the video, audio, presentation, and broadcasting professional on a daily basis. In recent years, we have redesigned and upgraded most of our line, making the best even better!

Getting Started

We recommend that you:

- Unpack the equipment carefully and save the original box and packaging materials for possible future shipment.
- Review the contents of this user manual.



Go to www.kramerav.com/downloads/VS-88H2A to check for up-to-date user manuals, application programs, and to check if firmware upgrades are available (where appropriate).

Achieving Best Performance

- Use only good quality connection cables (we recommend Kramer high-performance, high-resolution cables) to avoid interference, deterioration in signal quality due to poor matching, and elevated noise levels (often associated with low quality cables).
- Do not secure the cables in tight bundles or roll the slack into tight coils.
- Avoid interference from neighboring electrical appliances that may adversely influence signal quality.
- Position your Kramer **VS-88H2A** away from moisture, excessive sunlight and dust.

Safety Instructions



Caution:

- This equipment is to be used only inside a building. It may only be connected to other equipment that is installed inside a building.
- For products with relay terminals and GPIO ports, please refer to the permitted rating for an external connection, located next to the terminal or in the User Manual.
- There are no operator serviceable parts inside the unit.



Warning:

- Use only the power cord that is supplied with the unit.
- Disconnect the power and unplug the unit from the wall before installing.
- Do not open the unit. High voltages can cause electrical shock! Servicing by qualified personnel only.
- To ensure continuous risk protection, replace fuses only according to the rating specified on the product label which is located on the bottom of the unit.

Recycling Kramer Products

The Waste Electrical and Electronic Equipment (WEEE) Directive 2002/96/EC aims to reduce the amount of WEEE sent for disposal to landfill or incineration by requiring it to be collected and recycled. To comply with the WEEE Directive, Kramer Electronics has made arrangements with the European Advanced Recycling Network (EARN) and will cover any costs of treatment, recycling and recovery of waste Kramer Electronics branded equipment on arrival at the EARN facility. For details of Kramer's recycling arrangements in your particular country go to our recycling pages at www.kramerav.com/support/recycling.

Overview

Congratulations on purchasing your Kramer **VS-88H2A**.

VS-88H2A is a high-quality, 8x8 matrix switcher for 4K@60Hz (4:4:4), HDR, HDMI™ signals and analog & digital audio routing. It reclocks and equalizes the signals and can route any one of 8 HDMI, HDCP-compliant sources (selectable) to any or all outputs simultaneously. **VS-88H2A** offers unmatched audio flexibility where any embedded digital or analog audio input can be routed to any embedded digital or analog audio output in addition to 8 ARC sources to produce an equivalent 24x24 audio matrix.

The **VS-88H2A** provides exceptional quality, advanced and user-friendly operation, and flexible control.

Exceptional Quality

- High-Performance AV Matrix – Switches 8 4K@60Hz (4:4:4), HDR, HDMI, HDCP, DVI-compliant signals to 8 4K@60Hz (4:4:4), HDR, HDMI, HDCP, DVI-compliant outputs at up to 18G data rate. Signals are HDCP 2.2/1.4 compliant. Featuring Kramer re-Klocking™ and Equalization Technology that rebuilds the digital signal to travel longer distances.
For optimum range and performance, use recommended Kramer cables.
- Independent Audio Routing – Any embedded digital or analog audio input can be routed to any embedded digital or analog audio output in addition to eight ARC sources to produce an equivalent 24x24 audio matrix (8 embedded digital inputs + 8 analog inputs + 8 ARC inputs and 8 digital outputs + 8 analog outputs + 8 ARC outputs).
- Max. data rate – 18Gbps data rate (6Gbps per graphics channel).
- Max. resolution – Up to 4K@60Hz UHD (4:4:4).
- Step-in over HDMI technology.
- HDMI, HDCP and DVI Compliance.
- HDMI Support – Deep Color, 3D, ARC, up to 7.1 uncompressed audio channels as specified in HDMI 2.0.
- Kramer reKlocking™ and equalization technology – rebuilds the digital signal to travel longer distances.

Advanced and User-friendly Operation

- Easy Step-In Collaboration Function – When used with a Kramer Step-In enabled switcher, just plug in your device and press the Step-In button. Your device becomes the active signal on the main display.
- Convenient Unit Control and Configuration Options – Local control via front panel: switching, audio embedding, mute, test pattern, memory, EDID, front panel lock and factory reset buttons, Input/Output LED display. Distance control using user-friendly embedded web pages via Ethernet, Protocol 3000 API, and RS-232 serial commands transmitted by a PC, touch screen system or other serial controller.
- Cost-Effective Maintenance – Input Selection indicators facilitate easy local maintenance and troubleshooting. Firmware upgrade via Ethernet or mini-USB.
- Selectable switching speed.
- Audio level and balance support.
- Embedded pattern generator (480p) – With selectable patterns.
- Quick Access to Common Configurations – Save up to 16 preset configurations.
- EDID Management – Individual EDID management per input. Captures and stores the EDID from a display device.
- Smart Switching – Active source & acceptor detection. Automatic input selection based on priority selection or last connected input.
- ARC Support – on all inputs and outputs.
- Flexible Content Protection – Selectable HDCP per input.
- Easy front-panel operation.
- Lock button to prevent tampering.
- 5V/2A USB charger port.
- Kramer protocol 3000 support.
- Firmware upgrade via mini-USB, Ethernet or the RS-232 port, using embedded web GUI, Kramer Network or K-Load application.
- 7-segment display, indicating the video and audio status and other functions.
- Audio breakaway and AFV (audio-follow-video) operation support.
- Efficient power-saving features.
- Includes non-volatile memory that retains the last settings, after switching the power off and then on again.
- Input port active source detection as well as output port active sink detection.

Flexible Connectivity

- Supports up to eight analog audio inputs, eight digital audio inputs and 8 ARC inputs.
- Up to 24x24 switching for audio signals.
- 8x8 switching for HDMI signals.

- Optional ARC from HDMI outputs and analog audio inputs to HDMI inputs.
- Supports Step-in function.
- Housed in a 19" 1U rack mountable enclosure, with rack ears included, and is fed from a 100-240 VAC universal switching power supply.

Typical Applications

The **VS-88H2A** is ideal for the following typical applications:

- Presentation and multimedia applications.
- Systems that require automatic HDMI routing.

Controlling your **VS-88H2A**

Control your **VS-88H2A** directly via the front panel push buttons (with on-screen menus), or:

- By RS-232 serial commands transmitted by a touch screen system, PC, or other serial controller.
- Via the Ethernet using built-in user-friendly Web pages.

Defining VS-88H2A 4K HDMI 8x8 Matrix Switcher

This section defines VS-88H2A.

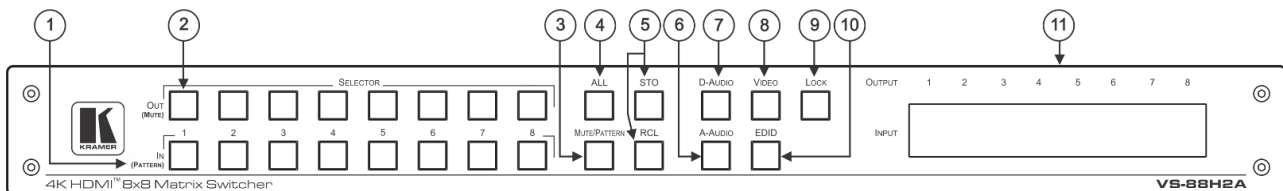



Figure 1: VS-88H2A 4K HDMI 8x8 Matrix Switcher Front Panel

#	Feature	Function
		The behavior of the front panel buttons and the 7-segment display changes along with the operation modes. For further details see Operating VS-88H2A via Front Panel Buttons on page 10 .
①	IN (PATTERN) SELECTOR Buttons	Press to select the input (1 to 8) to switch after selecting an output (also used for storing machine setups in the STO-RCL modes and for selecting a pattern in the Pattern mode).
②	OUT (MUTE) SELECTOR Buttons	Press to select an output (1 to 8) to which the input is routed. Also used for storing machine presets.
③	MUTE/PATTERN Button	Press to view the current pattern status and select the output/s to which a pattern is routed (see Routing a Pattern to the Output on page 17 or Switching a Pattern to an Output on page 35). Press to mute audio or video on a selected output when D-AUDIO/A-AUDIO, and/or VIDEO buttons are pressed (lit) (see Muting/Unmuting an Output on page 16).
④	ALL Button	Press to perform an action on all outputs (for example setting Mute mode, Pattern mode and so on). For switching, press ALL and then a specific IN button to route the selected input to all outputs. For example, press ALL and then IN 2 to route input 2 to all the outputs.
⑤	STO and RCL Buttons	Press STO to store the current switching setting to a preset button. Press RCL to recall the switching setting from a preset button (see Storing and Recalling a Setup on page 23).
⑥	A-AUDIO Button	Press to enable analog audio routing. When pressed together with VIDEO, the analog audio is routed together with the video signal.
⑦	D-AUDIO Button	Press to enable digital audio routing. When pressed together with VIDEO, the digital audio is routed together with the video signal.
⑧	VIDEO Button	Press to select video inputs. When pressed together with D-AUDIO/A-AUDIO, video is switched together with audio.
⑨	LOCK Button	Press and hold to toggle locking/releasing of the front panel buttons. Press to save the following setups: HDCP (On/Off), ARC, Fast Switch and Switch mode.
⑩	EDID Button	Press to capture the EDID (see Copying EDID on page 25 or Managing EDID on page 49).
⑪	OUTPUT/INPUT 7-segment LED Display	Displays the selected inputs switched to the outputs (marked above each input).

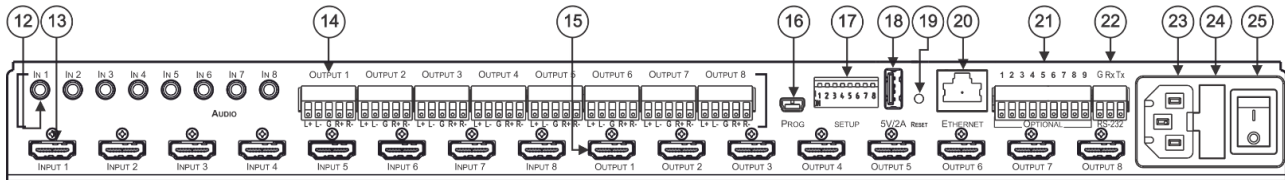

Figure 2: VS-88H2A 4K HDMI 8x8 Matrix Switcher Rear Panel

#	Feature	Function
12	AUDIO IN on 3.5 Mini Jack Connectors	Connect to unbalanced stereo analog audio sources (from 1 to 8).
13	INPUT HDMI Connectors	Connect to HDMI sources (from 1 to 8).
14	AUDIO OUTPUT on 5-pin Terminal Block Connectors	Connect to balanced stereo analog audio acceptor (from 1 to 8). (See Connecting Output to a Balanced/Unbalanced Stereo Audio Acceptor on page 9).
15	OUTPUT HDMI Connectors	Connect to HDMI acceptors (from 1 to 8).
16	PROG Mini USB Port	Use for firmware upgrade or communication (connecting to a PC or a serial controller).
17	SETUP DIP-Switches	For future use.
18	5V/2A USB Port	Use to charge a device.
19	RESET Button	Press and hold for 7-8 seconds to hard-reset the device to its factory default values (IP settings included).
20	ETHERNET RJ-45 Port	Connect to your LAN.
21	OPTIONAL Terminal Block Connectors	For future use.
22	RS-232 3-pin Terminal Block Connectors	Connect to a PC or a serial controller.
23	Mains Power Connector	Connect to the mains power.
24	Mains Power Fuse	Fuse for protecting the device.
25	Mains Power Switch	Switch for turning the device on or off.

Mounting VS-88H2A

This section provides instructions for mounting **VS-88H2A**. Before installing, verify that the environment is within the recommended range:



- Operation temperature – 0° to 40°C (32 to 104°F).
- Storage temperature – -40° to +70°C (-40 to +158°F).
- Humidity – 10% to 90%, RHL non-condensing.

**Caution:**

- Mount **VS-88H2A** before connecting any cables or power.

**Warning:**

- Ensure that the environment (e.g., maximum ambient temperature & air flow) is compatible for the device.
- Avoid uneven mechanical loading.
- Appropriate consideration of equipment nameplate ratings should be used for avoiding overloading of the circuits.
- Reliable earthing of rack-mounted equipment should be maintained.

Mount VS-88H2A in a rack:

- Attach both rack ears by removing the screws from each side of the machine and replacing those screws through the rack ears.

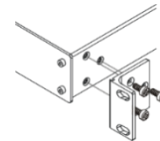

Connecting VS-88H2A



Always switch off the power to each device before connecting it to your VS-88H2A. After connecting your VS-88H2A, connect its power and then switch on the power to each device.

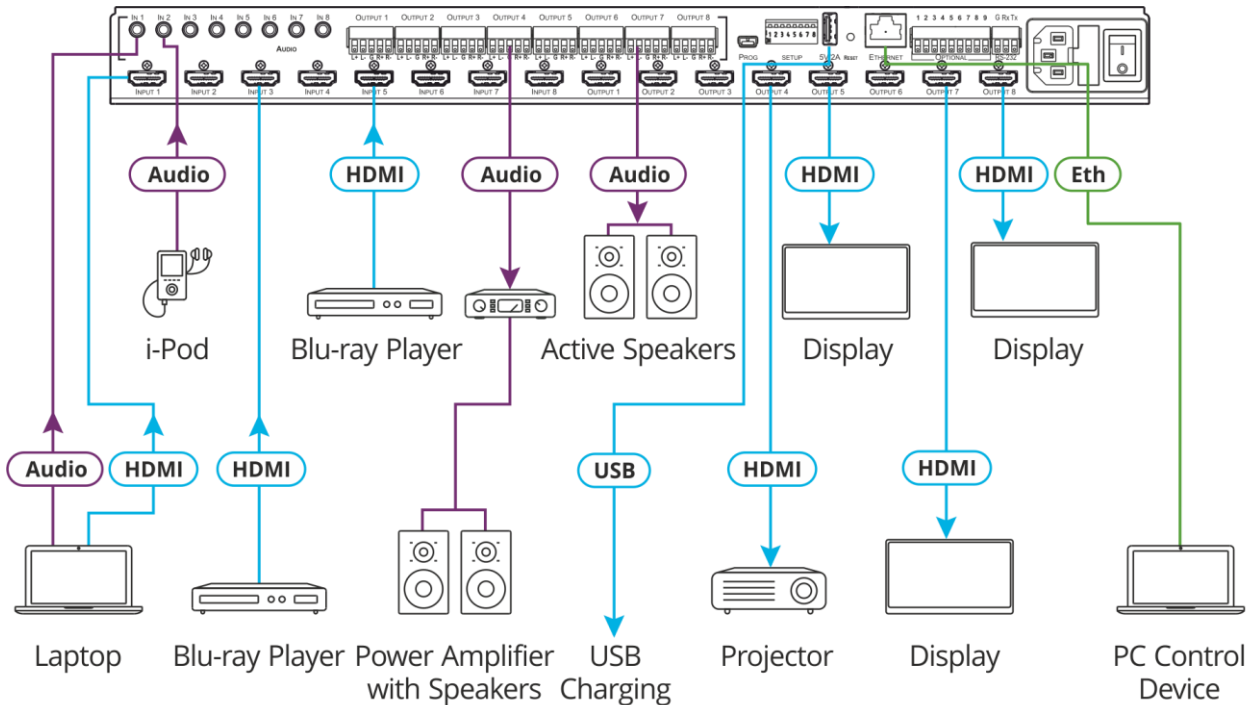

Figure 3: Connecting to the VS-88H2A Rear Panel

To connect VS-88H2A as illustrated in the example in [Figure 3](#):

- Connect up to eight video sources to the HDMI INPUT connectors ⁽¹³⁾ (from INPUT 1 to INPUT 8). For example, connect:
 - A laptop to INPUT 1.
 - Blu-ray players to INPUT 3 and INPUT 5.
- Connect up to eight analog stereo audio sources to the AUDIO IN 3.5mm mini jacks ⁽¹²⁾ (from IN 1 to IN 8). For example, connect:
 - The analog audio output of a laptop to AUDIO IN 1.
 - An i-Pod to AUDIO IN 2.
- Connect the eight video HDMI OUTPUT connectors ⁽¹⁵⁾ (from OUTPUT 1 to OUTPUT 8) to up to eight acceptors. For example, connect:
 - OUTPUT 4 to a projector.
 - OUTPUT 5, OUTPUT 7 and OUTPUT 8 HDMI each to a display.
- Connect the eight balanced analog output 5-pin terminal block connectors ⁽¹⁴⁾ (from OUTPUT 1 to OUTPUT 8) to up to eight audio acceptors. For example, connect:
 - OUTPUT 4 to a power amplifier with speakers.
 - OUTPUT 7 to active speakers.



See (see [Connecting Output to a Balanced/Unbalanced Stereo Audio Acceptor](#) on page 9).

5. If required, connect:
 - The 5V/2A USB port (18) to the USB port of another device to charge it.
 - The ETHERNET port (20) to a control device.
 - The RS-232 port (22) to a control device (not shown in [Figure 3](#)).
6. Connect the power cord to the power connector (23) and to the mains electricity (not shown in [Figure 3](#)).
We recommend that you use only the power cord that is supplied with this machine.

Connecting Output to a Balanced/Unbalanced Stereo Audio Acceptor

The following are the pinouts for connecting the output to a balanced or unbalanced stereo audio acceptor:

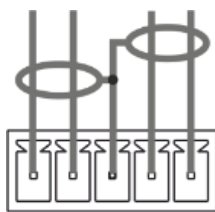

L+ L- G R+ R-

Figure 4: Connecting to a Balanced Stereo Audio Acceptor

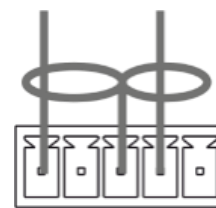

L+ L- G R+ R-

Figure 5: Connecting to an Unbalanced Stereo Audio Acceptor

Connecting to VS-88H2A via RS-232

You can connect to **VS-88H2A** via an RS-232 connection (22) using, for example, a PC.

VS-88H2A features an RS-232 3-pin terminal block connector allowing the RS-232 to control **VS-88H2A**.

Connect the RS-232 terminal block on the rear panel of **VS-88H2A** to a PC/controller, as follows:

From the RS-232 9-pin D-sub serial port connect:

- Pin 2 to the TX pin on the **VS-88H2A** RS-232 terminal block
- Pin 3 to the RX pin on the **VS-88H2A** RS-232 terminal block
- Pin 5 to the G pin on the **VS-88H2A** RS-232 terminal block

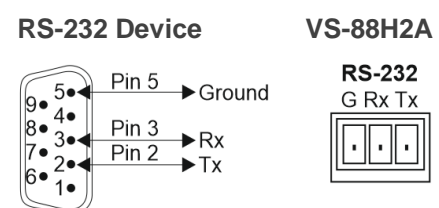

Operating VS-88H2A via Front Panel Buttons

Press the power switch (25) to power the device. During the 10-second initialization process, the:

- 7-segment display LEDs are on.
- All the front panel buttons illuminate.
- The FPGA/EPLD version (P), the firmware version (F) and the build version (b) appear in succession.

Following initialization, the front panel buttons and 7-segment display enter normal operation:

- The 7-segment display shows the video IN-OUT status.
- The current operation mode button illuminates (**VIDEO and D-AUDIO**, by default).
- An illuminated **IN (PATTERN)** button indicates an active signal connected to the input.
- An illuminated **OUT (MUTE)** button indicates that an acceptor is connected to the output.



By-default, the operation mode is set to VIDEO (8) and D-AUDIO (7) and both buttons illuminate.

In general, the front panel buttons indicate the device operation modes follows:

Button	LED Status	Operation Mode
VIDEO	On	Video inputs are switched to video outputs.
D-AUDIO	On	Digital inputs (HDMI input audio) are switched to digital outputs (HDMI output audio).
D-AUDIO	Flashing	Audio embedding: Analog audio inputs (12) are switched to digital audio outputs (HDMI output audio).
A-AUDIO	On	Audio de-embedding: Digital audio outputs (HDMI input audio) are switched to Analog audio outputs (14).
A-AUDIO	Flashing	Analog audio inputs are switched to analog audio outputs.
VIDEO	On	Video and digital inputs (HDMI) are switched to video and digital audio outputs (HDMI).
D-AUDIO	On	
VIDEO	On	Video inputs (HDMI) are switched to video outputs and analog audio inputs (AUDIO IN) are switched to digital audio outputs (HDMI).
A-AUDIO	On	
D-AUDIO	On	HDMI output ARC audio is switched to analog audio output.
A-AUDIO	On	
D-AUDIO	On	Analog audio input is switched to HDMI input ARC audio.
A-AUDIO	Flashing	
D-AUDIO	Flashing	HDMI output ARC audio is switched to HDMI input ARC audio.
A-AUDIO	On	



VS-88H2A setup processes timeout after 10 seconds.

The **VS-88H2A** front panel buttons enable performing the following functions:

- [Routing Signals](#), on page [11](#).
- [Storing and Recalling a Setup](#), on page [23](#).
- [Setting Switching Mode](#), on page [24](#).
- [Setting Switching Speed](#), on page [24](#).
- [Setting HDCP](#), on page [24](#).
- [Copying EDID](#), on page [25](#).

Routing Signals

You can switch the video and the audio signals together (AFV) or switch them separately, via the following switching modes:

- [Switching the Video Signal](#), on page [11](#).
- [Routing an Audio Input to the Analog Audio Output](#), on page [12](#).
- [Routing an Audio Input to the Digital HDMI Output](#), on page [14](#).
- [Switching Video and Audio Signal Simultaneously](#), on page [15](#).
- [Muting/Unmuting an Output](#), on page [16](#).
- [Routing a Pattern](#), on page [17](#).
- [Operating in ARC Mode](#), on page [18](#).

Switching the Video Signal

The **VIDEO** button on the **VS-88H2A** front panel enables video routing.

To switch a video input to an output:

1. Press **VIDEO** .

The button illuminates and the 7-segment display  shows the current IN-OUT video status.



On the front panel buttons:

- An illuminated input button means that an active signal is detected on that input.
- An illuminated output button means that a display is connected to that output.
- A flashing output button means that a non-HDCP display is connected to that output. Note that in the case that an HDCP-encrypted input is routed through the matrix to a non-HDCP screen, the video will not be presented and the non-HDCP screen will turn black.

On the 7-segment display:

- A digit (from 1 to 8) shows the input number that is currently routed to the output.
- “**P**” under an output number indicates that a pattern is routed to that output.
- “**0**” under an output number indicates that the output is muted.

2. Press an **OUT (MUTE)** (2) button (1 to 8).

The 7-segment display LED, under the selected output, flashes.



Press **ALL** (4) (instead of an output button) to route the selected input to all the outputs. All the 7-segment display LEDs flash.

3. Press an **IN (PATTERN)** button (1 to 8).

The selected input is switched to the selected output (or to all the outputs if **ALL** was pressed instead) and the 7-segment display shows the current status.

Routing an Audio Input to the Analog Audio Output

The **A-AUDIO** (6) button on the **VS-88H2A** front panel enables to route either the analog audio input signals (12) or the HDMI embedded audio signals (13) to the balanced stereo analog audio outputs (14).

Generally, analog routing is enabled by pressing **A-AUDIO**:

- When it is illuminated, the HDMI input embedded audio is the audio source.
- When it flashes, the 3.5mm analog audio input is the audio source.

To switch an HDMI digital audio input to an analog output:

1. Press **A-AUDIO** (6).

The button illuminates (HDMI audio input to balanced audio output mode) and the 7-segment display (11) shows the current IN-OUT analog audio status.



On the front panel buttons:

- An illuminated input button means that an active signal is detected on that input.
- Output button is not illuminated.

On the 7-segment display:

- “**A**” under an output number indicates that an analog audio input is the current audio source.
- “**C**” under an output number indicates that ARC audio is routed to that output.
- “**0**” under an output number indicates that the analog audio output is muted.
- “.” under an output number indicates that the HDMI output port is in ARC mode.
- Any digit shows the HDMI audio input switching state.

2. While **A-AUDIO** is on, select an output button (for example, 7) and then an input button (for example, 2). HDMI audio input 2 is routed to balanced stereo audio output 7 and on the 7-segment display, INPUT 2 appears under OUTPUT 7.

When switching you can also press:

- An output button (1 to 8) and then **OUT (MUTE)** ② to mute the selected output (turns 0).
- **ALL** ④ (instead of an output button) and then an input button to route the selected input to all the outputs.

All the 7-segment display LEDs flash and then display the selected input.

To switch an analog audio input to an analog output:

1. Press **A-AUDIO** ⑥ twice.

The button flashes (analog audio input to balanced audio output mode) and the 7-segment display ⑪ shows the current IN-OUT analog audio status.



On the front panel buttons:

- An illuminated input button means that a cable is connected to the 3.5mm minijack.
- An illuminated output button means that a display that supports audio is detected on that output.
- A dark button means either that the display that is connected does not support audio or that a display is not connected at all.

On the 7-segment display:

- “**d**” under an output number indicates that an embedded digital audio is currently routed to that output.
- “**C**” under an output number indicates that ARC audio is routed to that output.
- “**0**” under an output number indicates that the analog audio output is muted.
- “.” under an output number indicates that the HDMI output port is in ARC mode.
- Any digit shows the analog audio input switching state.

2. While **A-AUDIO** flashes, select an output button (for example, 8) and then an input button (for example, 1). Analog input 1 is routed to balanced stereo audio output 8 and on the 7-segment display, INPUT 1 appears under OUTPUT 8.

When switching you can also press:

- An output button (1 to 8) and then **OUT (MUTE)** ② to mute the selected output (turns 0).
- **ALL** ④ (instead of an output button) and then an input button to route the selected input to all the outputs.

All the 7-segment display LEDs flash and then display the selected input.

Routing an Audio Input to the Digital HDMI Output

The **D-AUDIO** (7) button on the **VS-88H2A** front panel enables to route either the analog audio input signals (12) or the HDMI embedded audio signals (13) to the HDMI outputs (15).

Generally, digital routing is enabled by pressing **D-AUDIO**:

- When it is illuminated, the HDMI input embedded audio is the audio source.
- When it flashes, the 3.5mm analog audio input is the audio source.

To switch an HDMI audio input to a digital output:

1. Press **D-AUDIO** (7).

The button illuminates (HDMI audio input to HDMI output mode) and the 7-segment display (11) shows the current IN-OUT digital audio status.



On the front panel buttons:

- An illuminated input button means that an active digital audio signal is detected on that input that supports LPCM audio.
- A dark input button means that there is no active digital audio source on that input (or that the source is DVI).
- A flashing input button means that a Dolby digital audio, Dolby-TrueHD audio, or AC-3 audio signal from a DVD -player is detected on that input.
- An illuminated output button means that a display that supports LPCM audio is connected to that output.
- A dark button means either that the display that is connected does not support audio or that a display is not connected at all.
- A flashing output button means that a display is connected that does not support LPCM.

On the 7-segment display:

- “**A**” under an output number indicates that an analog audio signal is currently routed to that output.
- “**0**” under an output number indicates that the audio output is muted.
- “.” under an output number indicates that the HDMI output port is in ARC mode.
- Any digit shows the HDMI audio input switching state.

2. While **D-AUDIO** is on, select an output button (for example, 6) and then an input button (for example, 5). HDMI audio input 5 is routed to HDMI audio output 6 and on the 7-segment display, INPUT 5 appears under OUTPUT 6.

When switching you can also press:

- An output button (1 to 8) and then **OUT (MUTE)** (2) to mute the selected output (turns 0).
- **ALL** (4) (instead of an output button) and then an input button to route the selected input to all the outputs.

All the 7-segment display LEDs flash and then display the selected input.

To switch an analog audio input to a digital output:

1. Press **D-AUDIO** twice (7).

The button flashes (analog audio input to HDMI output mode) and the 7-segment display (11) shows the current IN-OUT digital audio status.



On the front panel buttons:

- An illuminated input button means that a cable is connected to the 3.5mm mini jack.
- An illuminated output button means that a display that supports audio is connected to that output.
- A dark output button means either that the display that is connected does not support audio or that a display is not connected at all.

On the 7-segment display:

- “d” under an output number indicates that a digital audio signal is currently routed to that output.
- “0” under an output number indicates that the audio output is muted.
- “.” under an output number indicates that the HDMI output port is in ARC mode.
- Any digit shows the analog audio input switching state.

2. While **D-AUDIO** is on, select an output button (for example, 3) and then an input button (for example, 1). analog audio input 1 is routed to HDMI audio output 3 and on the 7-segment display, INPUT 1 appears under OUTPUT 3.

When switching you can also press:

- An output button (1 to 8) and then **OUT (MUTE)** (2) to mute the selected output (turns 0).
- **ALL** (4) (instead of an output button) and then an input button to route the selected input to all the outputs.

All the 7-segment display LEDs flash and then display the selected input.

Switching Video and Audio Signal Simultaneously

You can select the analog or the digital audio signal to switch to the output together with the video signal.

To switch the digital audio and video signals together to an output:

1. Press **D-AUDIO** and **VIDEO** simultaneously.

The button illuminates and the 7-segment display (11) shows the current IN-OUT video status.

2. Press an **OUT (MUTE)** (2) button (1 to 8).

The 7-segment display LED, under the selected output, flashes.



Press **ALL** (4) (instead of an output button) to route the selected input to all the outputs. All the 7-segment display LEDs flash.

3. Press an **IN (PATTERN)** button (1 to 8).
The selected audio input is switched to the selected output (or to all the outputs if **ALL** was pressed instead) and the 7-segment display shows the current status.

To switch the analog audio and video signals together to an output:

1. Press **A-AUDIO** and **VIDEO** simultaneously.
The buttons illuminate and the 7-segment display ⁽¹¹⁾ shows the current IN-OUT video status.
2. Press an **OUT (MUTE)** ⁽²⁾ button (1 to 8).
The 7-segment display LED, under the selected output, flashes.



Press **ALL** ⁽⁴⁾ (instead of an output button) to route the selected input to all the outputs. All the 7-segment display LEDs flash.

3. Press an **IN (PATTERN)** button (1 to 8).
The selected audio input is switched to the selected output (or to all the outputs if **ALL** was pressed instead) and the 7-segment display shows the current status.

Muting/Unmuting an Output

You can mute/unmute an audio signal and a video signal separately.

To mute/unmute an audio signal:

1. Press **A-AUDIO** or **D-AUDIO**.
The buttons illuminate.
2. Press an **OUT (MUTE)** ⁽²⁾ button (1 to 8).



Press **ALL** ⁽⁴⁾ (instead of an output button) to mute/unmute all the outputs. All the 7-segment display LEDs flash.

3. Press **MUTE/PATTERN** ⁽³⁾ to mute/unmute the output.
The muted output appears as “0” on the 7-segment display.

To mute/unmute a video signal:

1. Press **VIDEO**.
The button illuminates and the 7-segment display ⁽¹¹⁾ shows the current IN-OUT video status.
2. Press an **OUT (MUTE)** ⁽²⁾ button (1 to 8).
The 7-segment display LED, under the selected output, flashes.



Press **ALL** ⁽⁴⁾ (instead of an output button) to mute/unmute all the outputs. All the 7-segment display LEDs flash.

3. Press **MUTE/PATTERN** ⁽³⁾ to mute/unmute the output.
The muted output appears as “0” on the 7-segment display.

Routing a Pattern to the Output

VS-88H2A generates 6 embedded patterns. These patterns can be routed at a resolution of 480p to any of the outputs.

 Once a pattern is selected, that same pattern is routed to all the selected outputs.

A pattern is selected by pressing inputs 1 to 6 when in the Pattern mode.

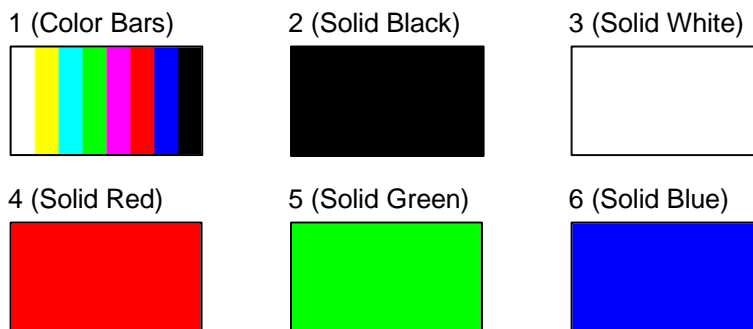

Figure 6: VS-88H2A Embedded Patterns

To route a pattern:

1. Press **MUTE/PATTERN** .



 On the front panel buttons:

- An illuminated output button means that a display is connected on that output.
- An illuminated input button indicates the current pattern selected.

On the 7-segment display:

- “**P**” under an output number indicates that a pattern is routed to that output.
- “**-**” under an output number indicates that a video input is routed to that output.
- “**0**” under an output number indicates that the output is muted.

2. Press an **OUT (MUTE)**  button (1 to 8).
The 7-segment display LED, under the selected output, flashes.

 Press **ALL**  (instead of an output button) to route a pattern to all the outputs. All the 7-segment display LEDs flash.

3. Press an input button to select a pattern (see [Figure 6](#)).
The 7-segment display shows the new pattern status.

 Press **VIDEO**, **D-AUDIO** or **A-AUDIO** to exit pattern mode.

Operating in ARC Mode

ARC (Audio Return Channel) can be set via the front panel buttons or the embedded webpages (see [Switching Audio in Breakaway Mode](#) on page 36 and [Setting Inputs](#) on page 33).

Generally:

- Press **ALL** and **MUTE/PATTERN** simultaneously to access ARC mode.
- When in ARC mode, INPUT button LEDs are off and OUTPUT button LEDs are either flashing (the output audio is from an ARC source) or ON (the output audio is not from an ARC source).
- Press **LOCK** to save changes to the ARC settings.
- Press **EDID** to exit ARC mode.
- If ARC features are not used for 10 seconds, the device exits ARC mode.

VS-88H2A features three types of audio return channels (ARC):

- [Routing HDMI Audio Output Signals to Balanced Audio Outputs](#) on page 18.
- [Routing HDMI Audio Output Signals to HDMI Input Ports](#) on page 20.
- [Routing Analog Audio Inputs to HDMI Input Ports](#) on page 21.

Routing HDMI Audio Output Signals to Balanced Audio Outputs

To route an HDMI audio output to a balanced stereo audio output, enable ARC on the HDMI output ports and then route them.

To set an HDMI output to ARC mode:



ARC can be enabled or disabled at any time, regardless of whether a display is connected to the HDMI output or not.

1. Press and hold **MUTE/PATTERN** and **ALL** simultaneously until both buttons illuminate and the device enters ARC mode:



On the front panel button:

- A flashing output button means that the audio of that output is set to ARC mode.
- An illuminated Output button means that the output is not in ARC mode.

2. Press one or more output buttons:

- If the selected button flashes, that output to set to ARC mode.
- If the selected button stops flashing, ARC mode is disabled for that output.

The **LOCK** button flashes.

3. Press **LOCK** to save changes.
The **LOCK** button flashes until the changes are saved. The device exits the ARC mode and returns to Video switching mode.



The ARC can be routed to any of the balanced audio outputs and to the HDMI inputs.

An HDMI audio output is routed to a balanced stereo audio output port.

To route an HDMI OUT ARC to a balanced stereo audio output port:

1. Press **D-AUDIO** and **A-AUDIO** simultaneously.
Both buttons illuminate and the device enters the ARC routing mode (for example, HDMI OUT 1, 2, 3 and 4 are enabled).



On the front panel button:

- An illuminated output button means that the corresponding output port is ARC enabled.

On the 7-segment display:

- “.” under an output number indicates that arc is enabled on the corresponding output (outputs 1 to 4 in this example).
- “A” under an output number indicates that an analog audio input is routed to that output.
- “d” under an output number indicates that the embedded audio is routed to that output.
- “0” under an output number indicates that the audio output is muted.

2. Press an output button (for example OUT 3). The corresponding 7-segment display LED flashes.
3. Press an output button (for example OUT 8) to select the balanced audio output routing destination.
The flashing 7-segment display LED shows the selected output number and ARC (for example, OUT 3) is routed to the selected balanced audio output (for example, OUT 8).

An HDMI OUT ARC is routed to a balanced stereo audio output port.

Routing HDMI Audio Output Signals to HDMI Input Ports

To route an HDMI audio output to HDMI input ports, enable ARC on the HDMI output ports and then route them.

To set an HDMI output to ARC mode:



ARC can be enabled or disabled at any time, regardless of whether a display is connected to the HDMI output or not.

1. Press and hold **MUTE/PATTERN** and **ALL** simultaneously until both buttons illuminate and the device enters ARC mode:



On the front panel button:

- A flashing output button means that the audio of that output is set to ARC mode.
- An illuminated Output button means that the output is not in ARC mode.

2. Press one or more output buttons:

- If the selected button flashes, that output is set to ARC mode.
- If the selected button stops flashing, ARC mode is disabled for that output.

The **LOCK** button flashes.

3. Press **LOCK** to save changes.

The **LOCK** button flashes until the changes are saved. The device exits the ARC mode and returns to Video switching mode.



The ARC can be routed to HDMI inputs and to any of the balanced audio outputs.

HDMI output is set to ARC mode.

To route an HDMI OUT ARC to an HDMI input port:

1. Press **D-AUDIO** and **A-AUDIO** simultaneously.
Both buttons illuminate and the device enters the ARC routing mode (for example, HDMI OUT 1, 2, 3 and 4 are enabled).
2. Press **D-AUDIO** until it flashes.
The out HDMI ARC-enabled outputs illuminate, as before.
The ARC-enabled inputs flash (for example, 1, 5 and 7 are ARC enabled, 3 is illuminated therefore not enabled).



On the front panel button:

- Output button is not illuminated.
- An illuminated input button means that it is a disabled ARC input.
- A flashing input button means that it is ARC-enabled.

On the 7-segment display:

- “.” under an output number indicates that arc is enabled on the corresponding output (outputs 1 to 4 in this example).
- “A” under an output number indicates that an analog audio input is routed to that output.
- “d” under an output number indicates that the embedded audio is routed to that output.
- “0” under an output number indicates that the audio output is muted.

3. Press an ARC enabled input button (for example IN 5) to select the destination port.
The corresponding 7-segment display LED flashes.
4. Press an output button (for example OUT 8) to select the HDMI audio output that will be routed to the input.
The flashing 7-segment display LED shows the selected input number and after selecting the HDMI audio OUT the port number appears (8).

An HDMI audio output is routed to an HDMI ARC input port.

Routing Analog Audio Inputs to HDMI Input Ports

To route an analog audio input to an HDMI input, enable ARC on the HDMI input ports and then route them.

To set an HDMI input to ARC mode:



ARC can be enabled or disabled at any time, regardless of whether an amplifier is connected to the HDMI input or not.

Inputs can be set either to the Step-in mode or the ARC mode.

1. Press and hold **EDID** and **ALL** simultaneously until both buttons illuminate and the device enters ARC mode:



On the front panel button:

- A flashing input button means that it is set to ARC mode.
- An illuminated input button means that it is set to Step-in mode.

2. Press one or more output buttons:

- If the selected button flashes, that input to set to ARC mode.
- If the selected button stops flashing, ARC mode is disabled for that input.

The **LOCK** button flashes.

3. Press **LOCK** to save changes.

The **LOCK** button flashes until the changes are saved. The device exits the ARC mode and returns to Video switching mode.

An HDMI input is set to ARC mode.

To route an analog audio input to an HDMI input port:

1. Press **D-AUDIO** and **A-AUDIO** simultaneously.

Both buttons illuminate and the device enters the ARC routing mode (for example, HDMI OUT 1, 2, 3 and 4 are enabled).

2. Press **A-AUDIO** until it flashes.

The out HDMI Arc-enabled outputs illuminate, as before.

The ARC-enabled inputs flash (for example, 1, 5 and 7 are ARC enabled, 3 is illuminated therefore not enabled).



On the front panel button:

- An illuminated output button means that the corresponding output port is ARC enabled.
- Output button is not illuminated.
- A flashing input button means that it is ARC-enabled.

On the 7-segment display:

- “.” under an output number indicates that arc is enabled on the corresponding output (outputs 1 to 4 in this example).
- “A” under an output number indicates that an analog audio input is routed to that output.
- “d” under an output number indicates that the embedded audio is routed to that output.
- “0” under an output number indicates that the audio output is muted.

3. Press an ARC enabled input button (for example IN 1) to select the input destination port.

The corresponding 7-segment display LED flashes.

- Press an input button (for example IN 6) to select the analog audio input that will be routed to the input destination port.
The flashing 7-segment display LED shows the selected input number and after selecting the HDMI audio IN the port number appears (6).

An analog audio input is routed to an HDMI input.

Storing and Recalling a Setup

VS-88H2A can store up to 16 setups. Each setup includes the video and audio current switching state, the output audio volume and balance, the EDID, the ARC/audio mode, and the switch mode and speed.

In Store-Recall mode, OUT 1 corresponds to setup 1, IN 1 corresponds to setup 9, and so on.

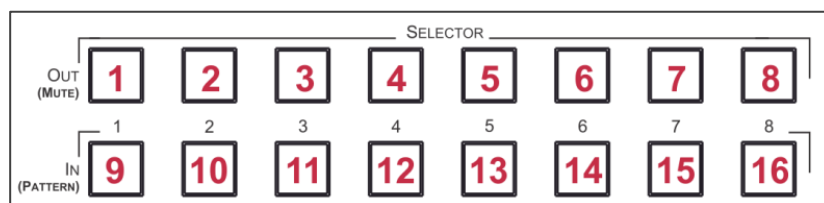

Figure 7: VS-88H2A 4K HDMI 8x8 Matrix Switcher Front Panel

To store a setup:

- Press **STO** ⑤.
The **STO** button illuminates.
 - Press an **IN** or an **OUT** button (from 1 to 8).
For example, when pressing IN 5, the current device state is stored to setup 13.
 - Press **STO**.
The current device state is stored to setup 13 and the **STO** button no longer illuminates.
- A setup is stored.

To recall a setup:

- Press **RCL** ⑤.
The **RCL** button illuminates.
- Press an **IN** or **OUT** button to recall the setup stored in that IN/OUT.
The selected button flashes.



If a setup is stored in the selected setup button, the corresponding 7-segment display LED flashes. If nothing is stored the 7-segment LED is on.

- Press **RCL**.
The recalled setup is applied and the **RCL** button no longer illuminates.



You need to press **RCL** within 10 seconds, to apply settings.

A setup is recalled.

Setting Switching Mode

Set the following switching modes separately for each output:

- Manual mode (**IN 1**): inputs are switched to outputs via the front panel buttons.
- Priority mode (**IN 2**): the **VS-88H2A** switches the source with the highest priority to the output.
- Last connected mode (**IN 3**): the last detected active source is switched to the output.

To select the switching mode:

1. Press **RCL** and **MUTE/PATTERN** simultaneously. Both buttons illuminate.
2. Press an output button (or press **ALL**).
The corresponding 7-segment display LEDs flash and **LOCK** button flashes.
3. Press **IN 1**, **IN 2** or **IN 3**.
4. Press **LOCK** to save the settings to that output and exit Switching mode.

Switching mode is selected.

Setting Switching Speed

Set the following switching speed modes separately for each output:

- Ex-Fast switch speed (**IN 1**).
- Fast switch speed (**IN 2**).
- Normal switch speed (**IN 3**).

To select the switching speed:

1. Press **STO** and **MUTE/PATTERN** simultaneously. Both buttons illuminate.
The 7-segment display LEDs show the current switch speed for each port.
2. Press an output button (or press **ALL**).
The corresponding 7-segment display LEDs flash and **LOCK** button flashes.
3. Press **IN 1**, **IN 2** or **IN 3**.
4. Press **LOCK** to save the settings and exit Speed mode.

Switching speed is set.

Setting HDCP

You can enable or disable HDCP for each of the HDMI inputs.

To set HDCP on or off:

1. Press and hold **EDID** and **RCL** until both buttons illuminate.
The IN buttons indicate the HDCP status:
 - HDCP 1.4 is enabled (on): IN button is illuminated.
 - HDCP 2.2 is enabled (on): IN button flashes.

- HDCP disabled (off): IN button is off.
2. Press one or more input buttons to change their status.
The **LOCK** button flashes.
 3. Press **LOCK** to save changes and exit the HDCP mode.
HDVP status is changed.

Copying EDID

You can copy the EDID to an input from a connected output or use the default EDID.

To copy the EDID from a connected output:

1. Press and hold **EDID** and **STO** until both buttons illuminate.
VS-88H2A enters the EDID mode and the 7-segment display shows the current EDID status:



On the front panel button:

- Both input and output buttons are dark.

On the 7-segment display:

- “**d**” under an output number indicates that the input port is set to the default EDID.
- “**L**” under an output number indicates that the EDID was uploaded externally from a file via Web page.
- A digit under an output number indicates the output from which the EDID was copied.

2. Press one or more input buttons (or **ALL**).
The 7-segment display LEDs of the selected inputs flash.
3. Press an output button (with a connected display) from which to copy the EDID.
4. Press **EDID**.
Wait for about 5 seconds for the device to copy the EDID from the connected display.
EDID is copied from a connected output.

To copy the default EDID:

1. Press and hold **EDID** and **STO** until both buttons illuminate.
VS-88H2A enters the EDID mode and the 7-segment display shows the current EDID status.
2. Press one or more input buttons (or **ALL**).
The 7-segment display LEDs of the selected inputs flash.
3. Press a disconnected output button.
4. Press **EDID**.
Wait for about 5 seconds for the device to copy the default EDID to the selected inputs.
EDID is copied from the default.

Operating via Ethernet

You can connect to **VS-88H2A** via Ethernet using either of the following methods:

- Directly to the PC using a crossover cable (see [Connecting Ethernet Port Directly to a PC](#) on page 26).
- Via a network hub, switch, or router, using a straight-through cable (see [Connecting Ethernet Port via a Network Hub](#) on page 28).



If you want to connect via a router and your IT system is based on IPv6, speak to your IT department for specific installation instructions.

Connecting Ethernet Port Directly to a PC

You can connect the Ethernet port of **VS-88H2A** directly to the Ethernet port on your PC using a crossover cable with RJ-45 connectors.



This type of connection is recommended for identifying **VS-88H2A** with the factory configured default IP address.

After connecting **VS-88H2A** to the Ethernet port, configure your PC as follows:

1. Click Start > Control Panel > Network and Sharing Center.
2. Click **Change Adapter Settings**.
3. Highlight the network adapter you want to use to connect to the device and click **Change settings of this connection**.

The Local Area Connection Properties window for the selected network adapter appears as shown in [Figure 8](#).

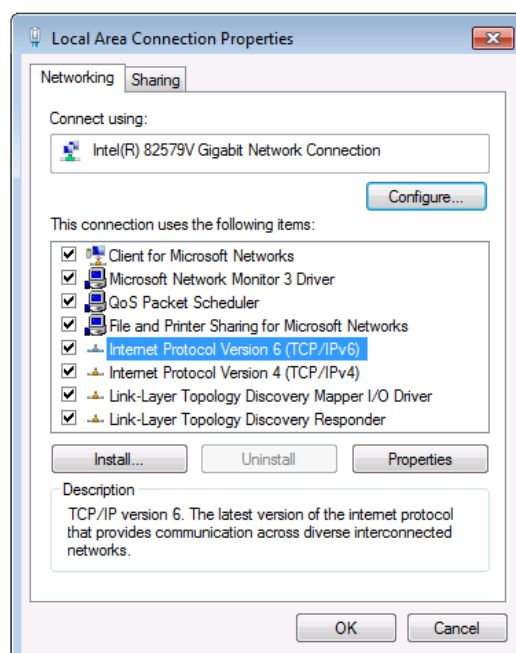

Figure 8: Local Area Connection Properties Window

4. Highlight either **Internet Protocol Version 6 (TCP/IPv6)** or **Internet Protocol Version 4 (TCP/IPv4)** depending on the requirements of your IT system.

5. Click **Properties**.

The Internet Protocol Properties window relevant to your IT system appears as shown in [Figure 9](#) or [Figure 10](#).

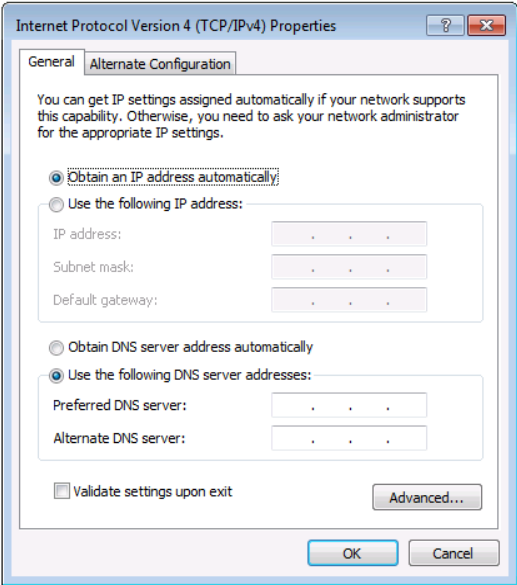

Figure 9: Internet Protocol Version 4 Properties Window

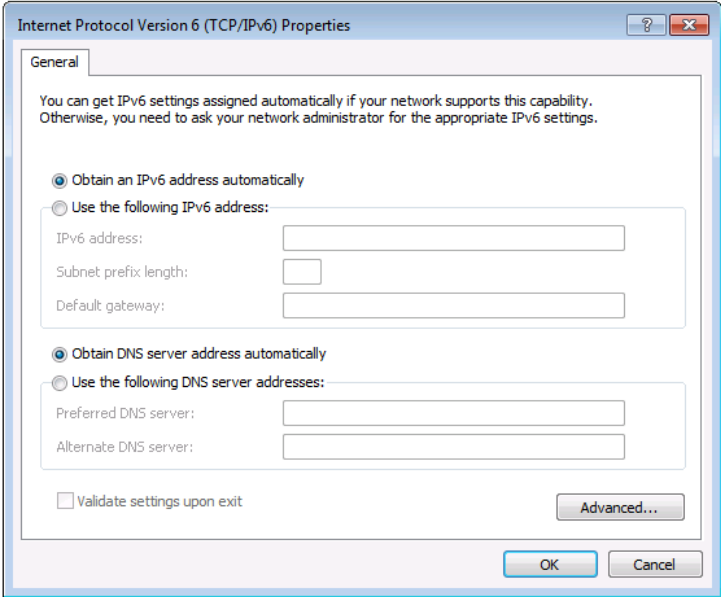

Figure 10: Internet Protocol Version 6 Properties Window

6. Select **Use the following IP Address** for static IP addressing and fill in the details as shown in [Figure 11](#).

For TCP/IPv4 you can use any IP address in the range 192.168.1.1 to 192.168.1.255 (excluding 192.168.1.39) that is provided by your IT department.

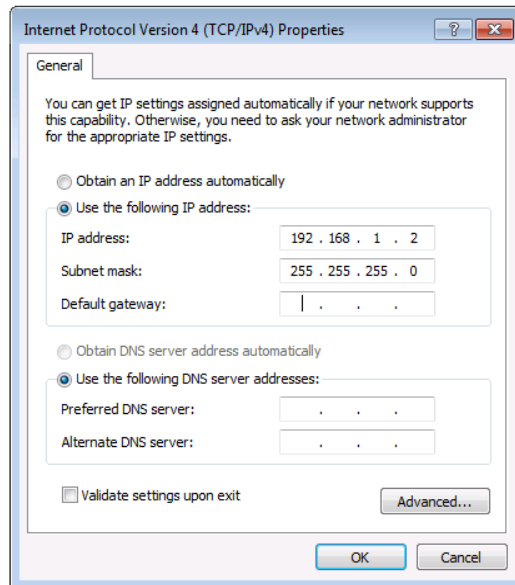

Figure 11: Internet Protocol Properties Window

7. Click **OK**.
8. Click **Close**.

Connecting Ethernet Port via a Network Hub or Switch

You can connect the Ethernet port of VS-88H2A to the Ethernet port on a network hub or using a straight-through cable with RJ-45 connectors.

Configuring Ethernet Port

You can set the Ethernet parameters via the embedded Web pages.

Using Embedded Web Pages

VS-88H2A can be operated remotely using the embedded Web pages. The Web pages are accessed using a Web browser and an Ethernet connection.

Before attempting to connect:

- Perform the procedures in [Operating via Ethernet](#) on page [26](#).
- Ensure that your browser is supported.

The following operating systems and Web browsers are supported:

Operating Systems	Versions
Windows 7	IE
	Firefox
	Chrome
	Safari
Windows 10	IE
	Edge
	Firefox
	Chrome
Mac	Safari
iOS	Safari



Some features might not be supported by some mobile device operating systems.

VS-88H2A enables performing the following:

- [Switching and Setting Ports](#) on page [30](#).
- [Changing Device Settings and Upgrading Firmware](#) on page [38](#).
- [Managing Web Page Security](#) on page [40](#).
- [Setting the Timeout](#) on page [44](#).
- [Setting Switching Modes](#) on page [45](#).
- [Setting Step-in Devices](#) on page [47](#).
- [Managing EDID](#) on page [49](#).
- [Viewing About Us Page](#) on page [55](#).

To browse the VS-88H2A web pages:

1. Open your Internet browser.
2. Type the IP address of the device in the address bar of your browser. For example, the default IP address:



The Authentication window appears (if set, security is enabled):

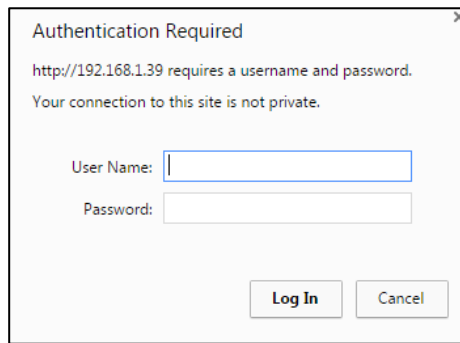

Figure 12: Using the Embedded Web Pages – the Authentication Window

3. Enter the **User Name** and **Password** and click **OK**.

The Switching page appears:

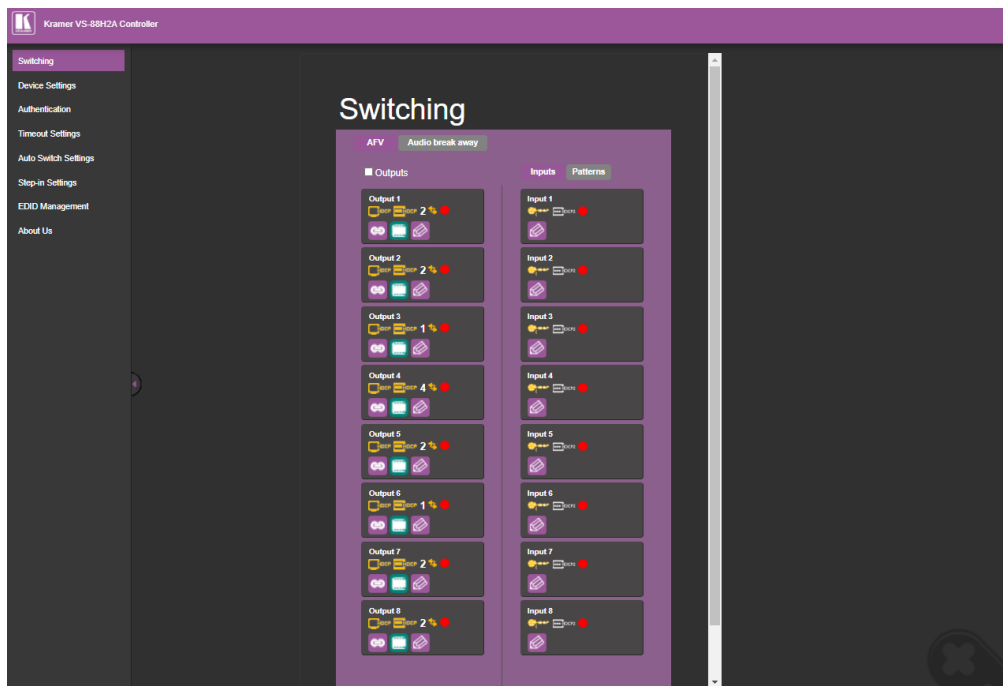

Figure 13: Switching Page with Navigation List on Left

4. Click the desired Web page or click the arrow to hide the navigation list.

You can browse webpages.

Switching and Setting Ports

The Switching Web page enables performing the following functions:

- [Viewing and Adjusting Output Settings](#) on page [31](#).
- [Viewing and Adjusting Input Settings](#) on page [32](#).
- [Switching an Input to an Output](#) on page [34](#).
- [Switching a Pattern to an Output](#) on page [35](#).
- [Switching Audio in Breakaway Mode](#) on page [36](#).

Viewing and Adjusting Output Settings

View and adjust the settings for each VS-88H2A output.



Figure 14: Switching Page – Output Button

Each output button displays the:

- HDCP status – output supports HDCP (HDCP icon) or does not support HDCP (HDCP icon).
- HDCP out – follow input HDCP (HDCP icon), support HDCP 1.4 (HDCP1 icon) or HDCP 2.2 (HDCP2 icon).
- View the input switched to the output (for example, 2).
- Switching speed – normal (lightning bolt icon), fast (lightning bolt icon) or extra-fast (lightning bolt icon).
- Output status – an acceptor is connected (green circle icon) or not connected (red circle icon) to the output.

To adjust the output settings:

1. In the Navigation pane, click **Switching**. The Switching page appears.
2. Select the **AFV** tab.



The adjustment sequence presented here is only an example. You can adjust the output settings in any other order.

3. Click (edit icon). The output settings window appears:

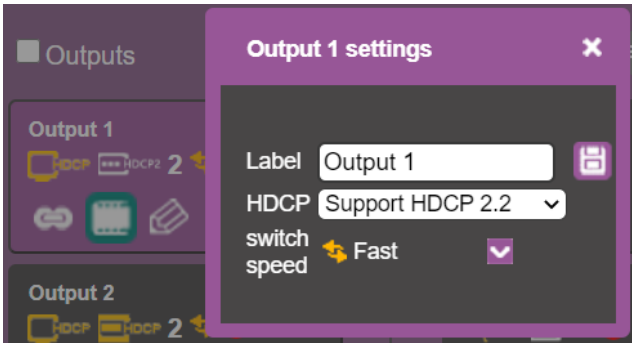



Figure 15: Switching Page – Editing the Output Button Settings

4. If required, type the label name in the **Label** text box and click .

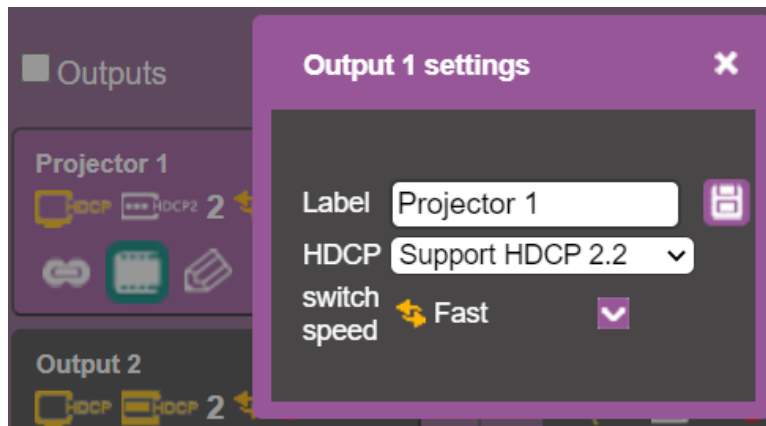





Figure 16: Switching Page – Changing the Output Label

5. Click **switch speed** dropdown box to set the switching speed (normal, fast or extra-fast).
6. Click  to mute or  to unmute the video signal.
7. To set the output to:
- AFV mode, click .
 - Breakaway mode, click .

 indicates that the device is in the auto-switch mode and AFV status cannot be altered.



Setting the AFV mode icons to AFV or Breakaway modes reflects the next switching step and not the current status.

Output settings are adjusted.

Viewing and Adjusting Input Settings

View and adjust the settings for each VS-88H2A input.

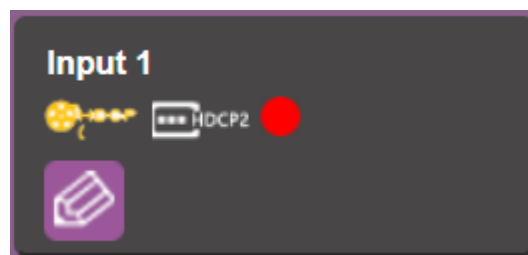







Figure 17: Switching Page – Input Button

Each input button displays the:

- HDCP status – HDCP is enabled () or disabled (.
- Input signal HDCP status – supports HDCP () or does not support HDCP (.
- Input status – a source is connected () or not connected () to the input.

Input settings are adjusted.

Setting Inputs

To adjust input settings:

1. In the Navigation pane, click **Switching**. The Switching page appears.
2. Select the **AFV** tab. Verify that **Inputs** (and not **Patterns**) is selected.
3. Click . The input settings window appears:

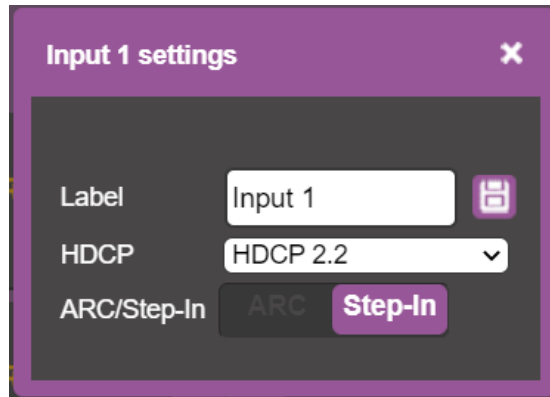



Figure 18: Switching Page – Input 1 Settings Window

4. If required, type the label name in the **Label** text box and click .
5. Set HDCP **HDCP 2.2**, **HDCP 1.4** or **No HDCP**.
6. Click **ARC** to set input to ARC mode or click **Step-In** to set input to step-in mode.
7. In ARC mode click the settings button ().
The input ARC Settings window appears:

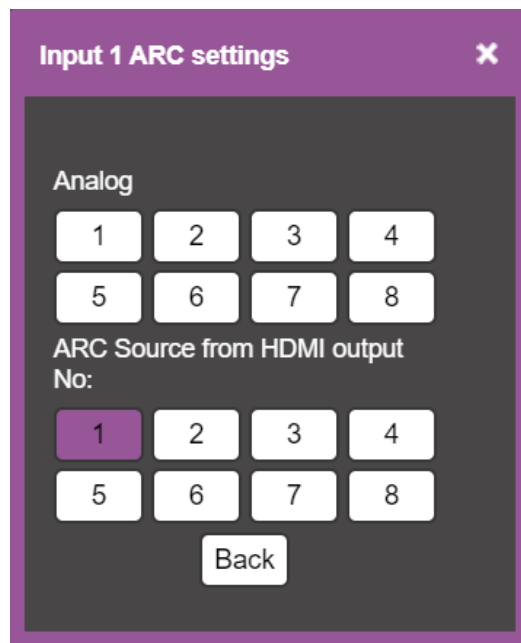

Figure 19: Switching Page – Input ARC Settings Window

8. Select an ARC source for input 1: either from analog inputs IN 1 to IN 8, or from HDMI outputs 1 to 8.

The selected port routes its audio signal to HDMI input 1.

Switching an Input to an Output

To move the image:

1. In the Navigation pane, click **Switching**. The Switching page appears.
2. Select the **AFV** tab.



Figure 20: Switching Page – AFV Tab

3. Click an output button or check the **Outputs** box. The button turns purple.
4. Click an Input button. The button turns purple.

The selected input is switched to the output.

Switching a Pattern to an Output

To switch a pattern to the output:

1. In the Navigation pane, click **Switching**. The Switching page appears.
2. Select the **AFV** tab. Verify that **Patterns** (and not **Inputs**) is selected. The list of patterns appears.



Figure 21: Switching Page – Switching a Pattern to an Output

3. Select an output button or check the **Outputs** box.
4. Select a pattern.

The selected pattern is switched to the selected output.

Switching Audio in Breakaway Mode

In breakaway mode, the HDMI embedded audio is switched separately from the video signal.



The audio breakaway mode is enabled only when Auto Switch Setting is set to Manual mode.



Set the volume and balance of each analog output using the appropriate sliders or mute/unmute the audio signal of an output:

Label	Audio Outputs			Volume	Analog Outputs			Balance	Inputs		
	ARC	HDMI	Analog		dB	Mute			Digital	Analog	ARC
Projector 1	<input type="checkbox"/>	D1	D5	<input type="range"/>	-8	<input type="checkbox"/>	<input type="range"/>	75	1	1	1
Output 2	<input type="checkbox"/>	D3	A3	<input type="range"/>	11.5	<input type="checkbox"/>	<input type="range"/>	50	2	2	2
Output 3	<input checked="" type="checkbox"/>	D3	A6	<input type="range"/>	-40	<input type="checkbox"/>	<input type="range"/>	50	3	3	3
Output 4	<input type="checkbox"/>	D3	A4	<input type="range"/>	0	<input type="checkbox"/>	<input type="range"/>	50	4	4	4
Output 5	<input type="checkbox"/>	D3	D8	<input type="range"/>	6	<input type="checkbox"/>	<input type="range"/>	50	5	5	5
Output 6	<input type="checkbox"/>	D3	A3	<input type="range"/>	20	<input type="checkbox"/>	<input type="range"/>	50	6	6	6
Output 7	<input checked="" type="checkbox"/>	D3	ARC7	<input type="range"/>	0	<input type="checkbox"/>	<input type="range"/>	50	7	7	7
Output 8	<input checked="" type="checkbox"/>	D3	A7	<input type="range"/>	-35	<input type="checkbox"/>	<input type="range"/>	50	8	8	8

Figure 22: Switching Page – Switching Audio in the Breakaway Mode

You can switch a digital input to a digital or analog output and an analog input to a digital or analog output. If ARC mode is enabled, you can switch a selected ARC to any of the analog outputs.

To switch an audio input to an audio output:

1. In the Navigation pane, click **Switching**. The Switching page appears.
2. Select Audio break away tab.
3. Switch an input to a selected output. For example, switch digital input 6 to analog output 2:
 - Click an **HDMI** or **Analog** button (under the **Audio Outputs** column). The selected button turns purple with a black frame .
 - Click a **Digital** or **Analog** button (under the **Inputs** column). The selected button turns purple with a blue frame .

Analog Output 3 is switched to D6   .

To switch ARC to an output:

1. In the Navigation pane, click **Switching**. The Switching page appears.
2. Select Audio break away tab.
3. Check the ARC check boxes to set these outputs that are set to ARC mode. (under the **Audio Outputs** column).

For example, output 1 is set to ARC mode so the output 1 audio signal returns to the input and can be switched to any analog output. Once an output is set to the ARC mode, the **Inputs ARC** button (on the right) is enabled and changes from gray to white.

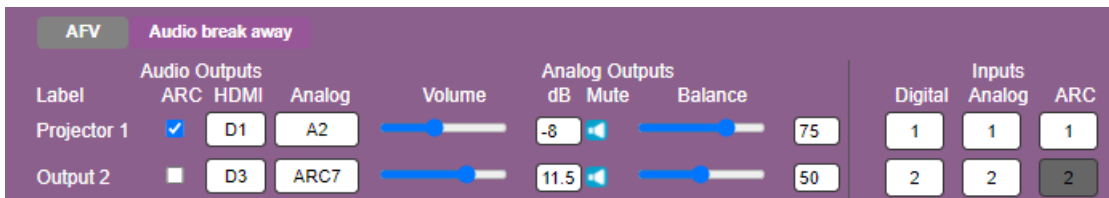

Figure 23: Switching Page – Output 1 Set to ARC Mode

4. Switch an ARC input to a selected output. For example, switch ARC 1 to output 8:

- Click an analog output button **8**.
- Click an ARC button **1**.

Analog Output 8 is switched to ARC 1 .

An ARC is switched to an output.

Changing Device Settings and Upgrading Firmware

The Device Settings Web page shows the device details, such as name, MAC address and firmware version and also enables performing the following functions:

- [Changing the Ethernet Settings](#) on page [38](#).
- [Performing a Factory Reset](#) on page [39](#).
- [Performing Firmware Upgrade](#) on page [39](#).

Changing the Ethernet Settings

To change the Ethernet settings:

1. In the Navigation pane, click **Device Settings**. The Device Settings page appears:

Figure 24: Device Settings Page

2. Uncheck/check the **DHCP** check box.
3. If DHCP is unchecked, change any of the parameters (IP Address, Netmask and/or Gateway).
4. Click **Save Changes**.



Note that:

- After changing the IP number, reload the Web page with the new IP address.
- After changing the Subnet mask you need to turn the **VS-88H2A** power off and then on again.
- If DHCP is checked, reload the Web page with the new IP address.

Ethernet settings are changed.

Performing a Factory Reset

To reset the device to its factory default values:

1. In the Navigation pane, click **Device Settings**. The Device Settings page appears ([Figure 24](#)).
2. Click **Reset**. The following window appears:

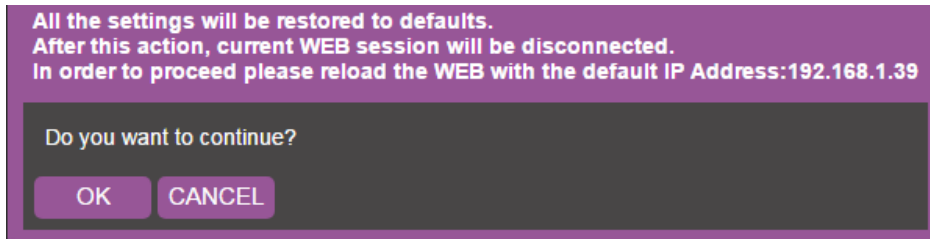

Figure 25: Device Settings Page – Factory Reset

3. Click **OK** to start factory reset and follow the instructions on-screen.

VS-88H2A resets to its factory default settings.

Performing Firmware Upgrade

To perform firmware upgrade:

1. In the Navigation pane, click **Device Settings**. The Device Settings page appears ([Figure 24](#)).
2. Click **BROWSE** and select the new firmware file.
3. Click **START UPGRADE** and follow the instructions on-screen.

Firmware is updated.

Managing Web Page Security

Use the Authentication page to set Web access permission:

To define access to the Web pages In the Navigation pane, click **Authentication**. The Password Settings page appears displaying the current status (password protected or free access). By-default, security is set to off.

To access Web pages using the password:

1. Check the current security status.

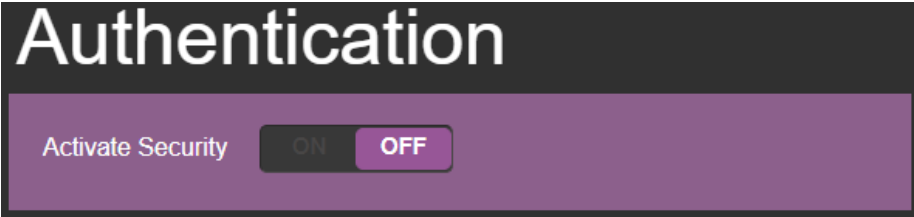

Figure 26: Authentication Page – Security Deactivated

2. Set **Activate Security** to **ON** for Web page password protection. The following window appears:

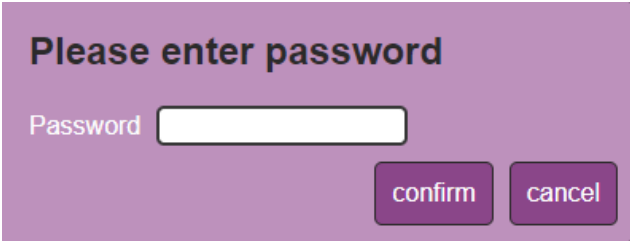

Figure 27: Authentication Page – Enter Password Message

3. Enter the previous password (empty, by-default).
4. Click **Confirm**. The following message appears:

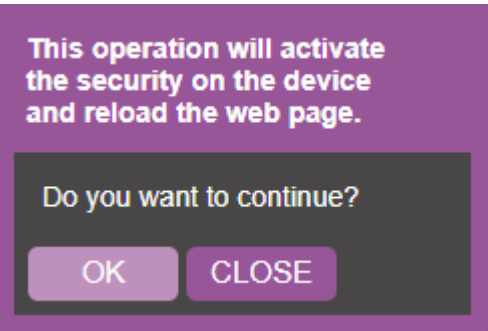

Figure 28: Authentication Page – Security Activation Message

- 5. Click **OK**.
The connection is interrupted, and authentication is required to access Web pages.

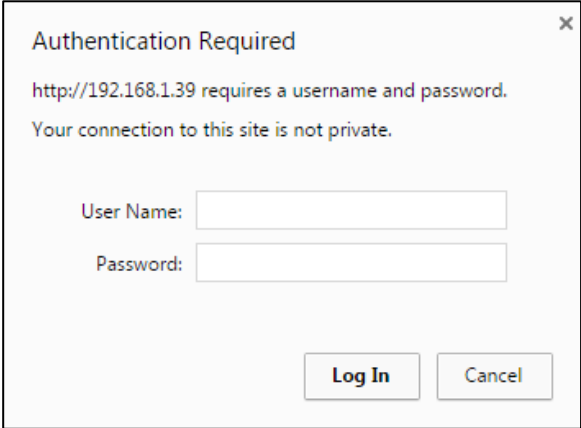

Figure 29: Authentication Page – Security Log In

- 6. Type the User Name (Admin, by default) and Password (left empty by default).

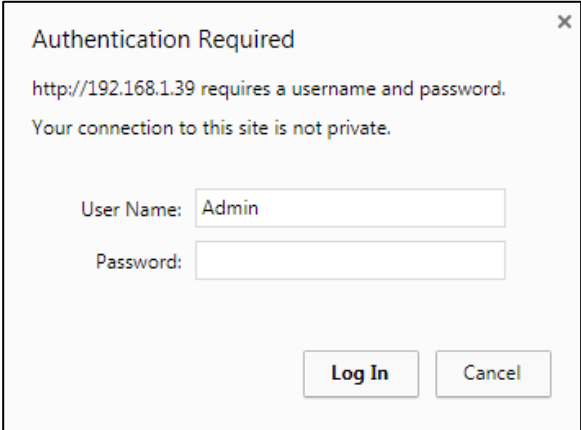

Figure 30: Authentication Page – Password Protection

- 7. Click **Log In**.
- 8. Select **Authentication** from the Navigation pane.

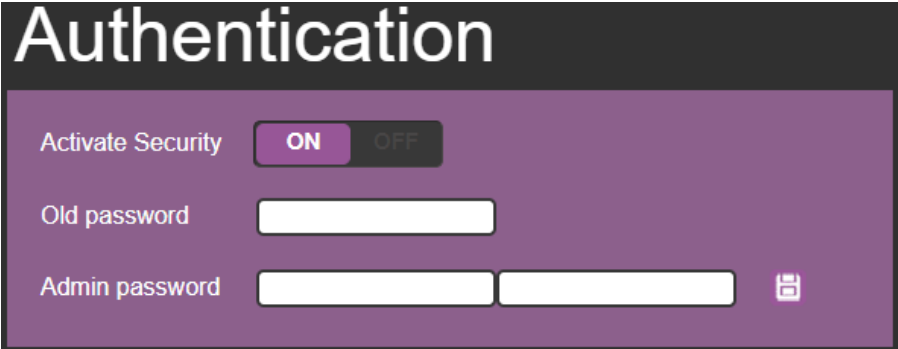

Figure 31: Authentication Page – Setting the Admin Password

- Type the new Admin password twice in both **Admin password** text boxes.

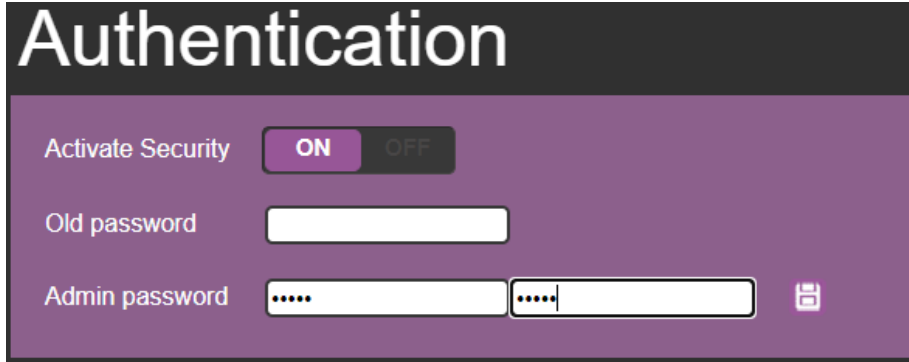



Figure 32: Authentication Page – Entering the Admin Password

- Click . The following message appears:

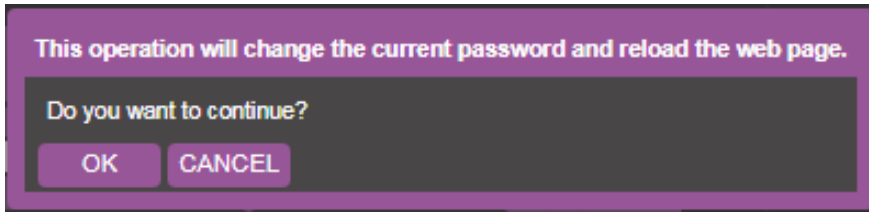

Figure 33: Authentication Page – Password Warning

- Click **OK**.

The page is reloaded and can be accessed by entering the password. The top right side of the Web page displays the security icon:



Figure 34: Authentication Page – Admin Icon Security Enabled

The **VS-88H2A** embedded webpage is password protected.

To access Web pages without using the password:

- In the Navigation pane, click **Authentication**. The Authentication page appears.

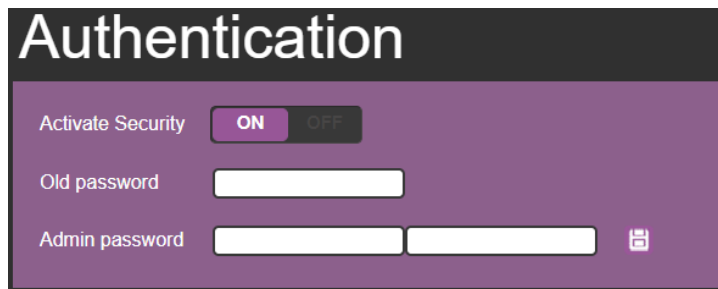

Figure 35: Authentication Page – Password Protected

2. Click **OFF**. The following message appears:

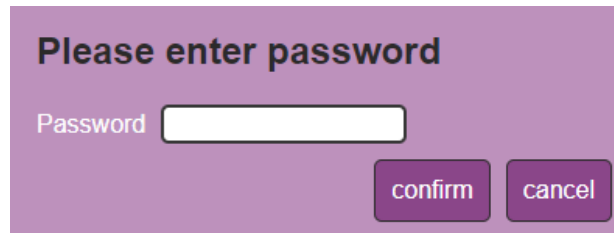

Figure 36: Authentication Page – Entering the Latest Password

3. Enter the current password and click **confirm**.

The following message appears:

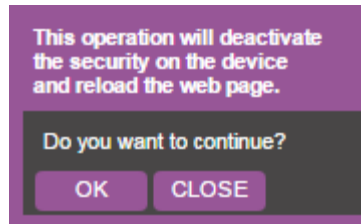

Figure 37: Authentication Page – Deactivating the Security

4. Click **OK**.

The page reloads and can be accessed without entering the password.

The top right side of the Web page displays the security icon:



Figure 38: Authentication Page – Admin Icon Security Disabled

The **VS-88H2A** embedded webpage is not password protected.

Setting the Timeout

Use the **Timeout Settings** web page to set the time delay to shut down if no input signal is detected for each output and to set the auto switching time.

-  Always set the 5V cut-off (Disable 5V) time delay to be longer than the video signal loss timer delay.

To set the timeout:

1. In the Navigation pane, click **Timeout Settings**. The Timeout Settings page appears.

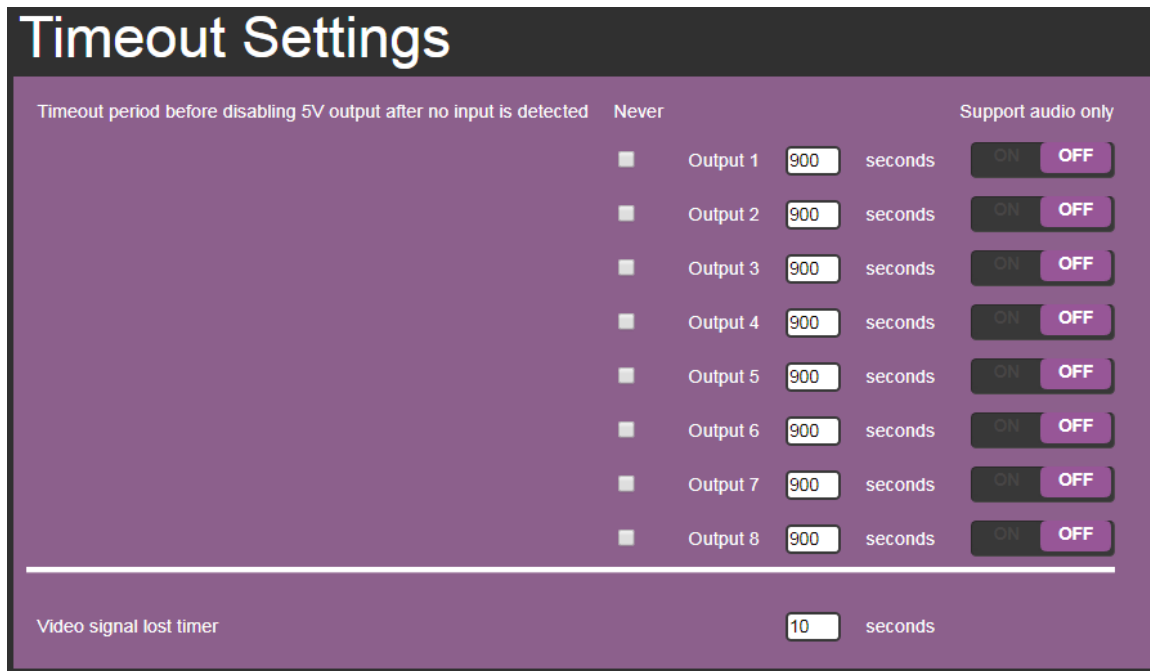

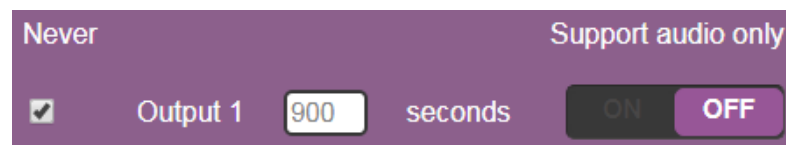



Figure 39: Timeout Settings Page

2. Set the specific output delay time.

-  If you do not want a specific output to shut down if an input signal is not detected, check the **Never** box next to the desired output.



3. Set audio support **ON** if you want shutdown to occur only if an audio signal is lost.

-  **Support audio only** can be used if the video and audio signals routed to an output, come from separate sources.

If **Support audio only** is set to:

- **ON** – The audio signal routed to the output remains active when the video source (coming from a different input) is deactivated.
- **OFF** – The audio signal routed to the output is deactivated together with the deactivation of the video source (coming from a different input).

Timeouts are set.

To set the video lost timer (when in auto-switching mode):

1. In the Navigation pane, click **Timeout Settings**. The Timeout Settings page appears.
2. Set the video lost timer.



The adjustment sequence presented here is only an example. You can adjust the output settings in any other order.



If the video is lost when in the auto switching mode (Priority or Last connected) you can set the time the device waits before it switches to the next source.

Video lost timer is set.

Setting Switching Modes

Use the **Auto Switch Settings** page to set the switching mode per output.



Setting to priority or last connected mode forces **VS-88H2A** to operate in AFV mode.

To set the switching mode:

1. In the Navigation pane, click **Auto Switch Settings**. The Auto Switch Settings page appears.

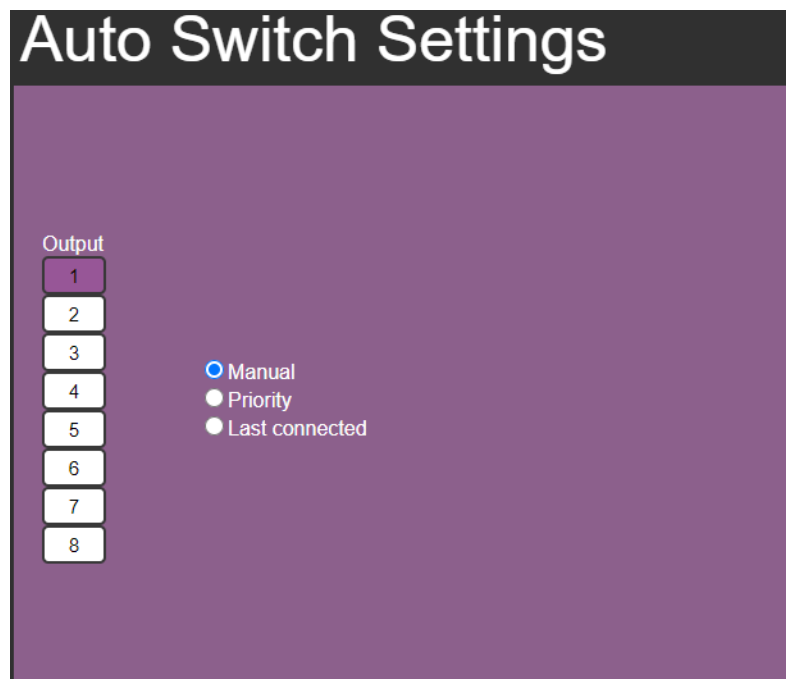

Figure 40: Auto Switch Settings Page

2. Select an output and set the switching mode to **Manual**, **Priority** or **Last connected**:
 - In the Manual mode (see [Figure 40](#)), the outputs are switched manually to the selected output.

- In the Priority mode, drag and drop the inputs from the highest to the lowest priority. The inputs are then switched according to the set priority to the selected output:

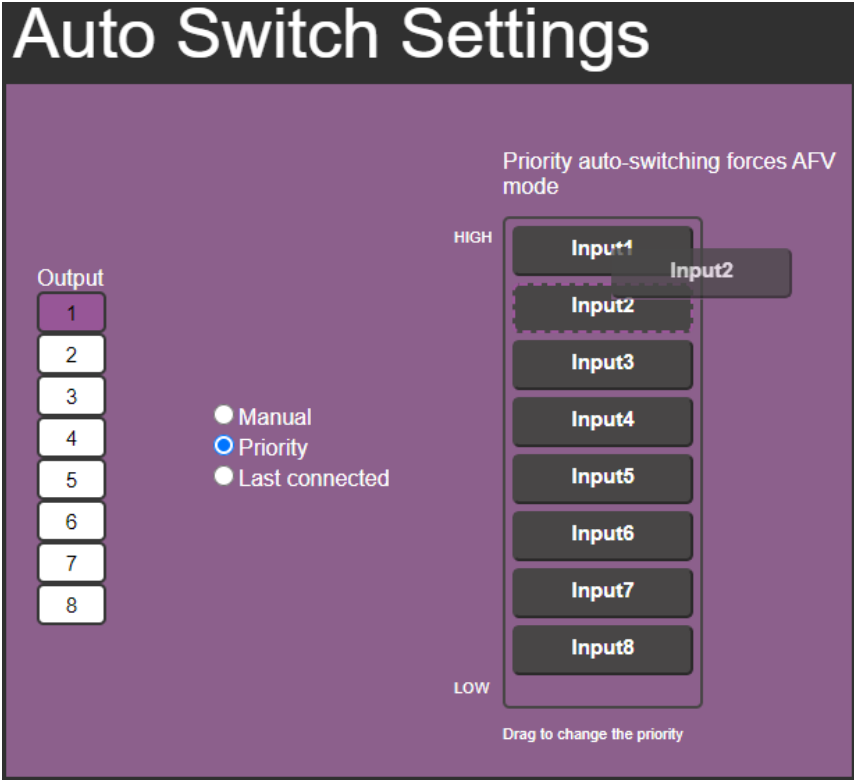

Figure 41: Auto Switch Settings Page – Setting the switching Priority

- In the Last connected mode, select the inputs that are included in the last connected scan that will be switched to the selected output:

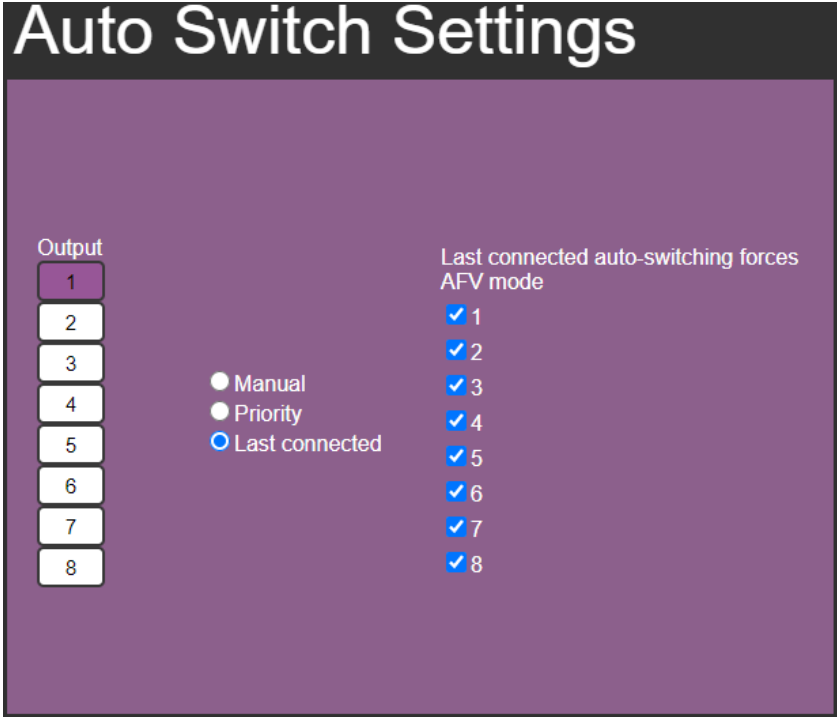

Figure 42: Auto Switch Settings Page – Last Connected Mode

Switching mode is set.

Setting Step-in Devices

Use the Step-In Settings page to manage Step-in devices (for example Kramer **DIP-30**).

If a step-in device is not connected to **VS-88H2A**, the following page appears:

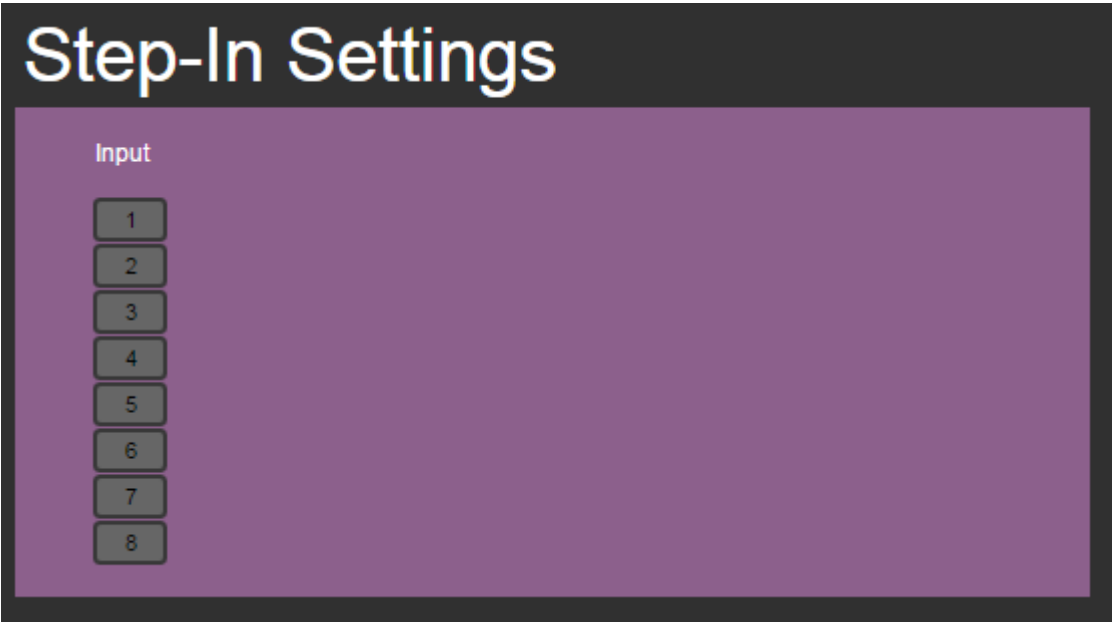

Figure 43: Step-In Settings Page (Step-in Device is not Connected)

To manage a step-in device:

- 1. Connect the HDMI output of a step-in device (for example **DIP-30**) to an HDMI input on the **VS-88H2A**.
- 2. In the Navigation pane, click **Step-In Settings**. The Step-In Settings page appears and the input button/s to which the step-in device/s is connected turn/s white.

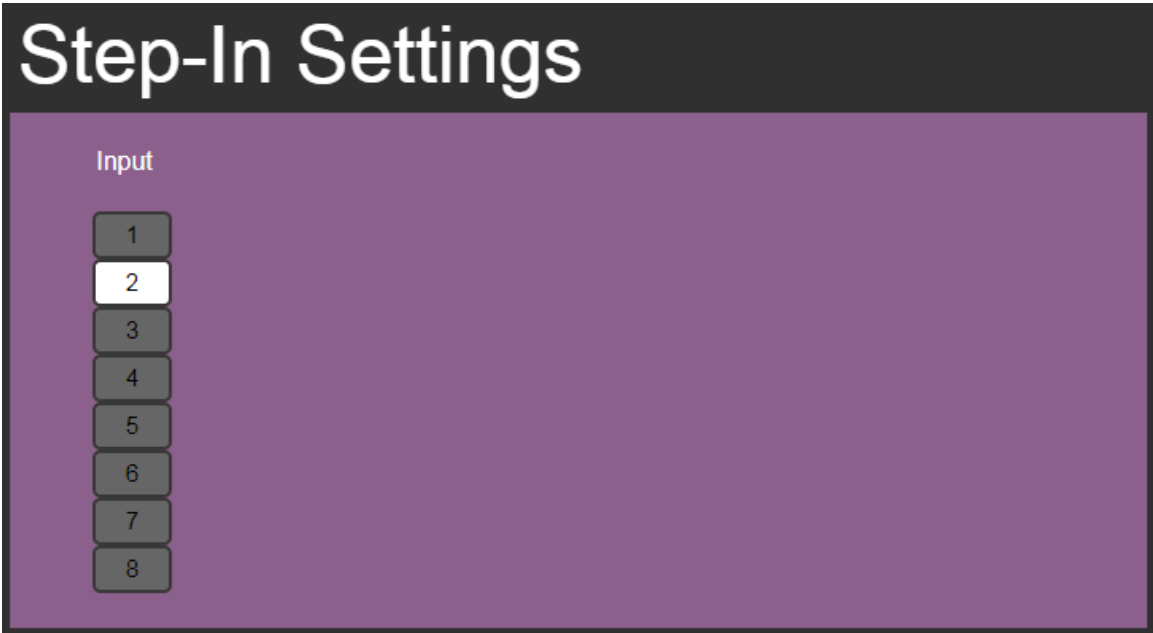

Figure 44: Step-In Settings Page – Displaying Step-In Inputs

- Click an active step-in input (button 1 in this example).
The selected input button turns purple, the **DIP-30** Inputs list and the **VS-88H2A** outputs to which the **DIP-30** input is routed are displayed.

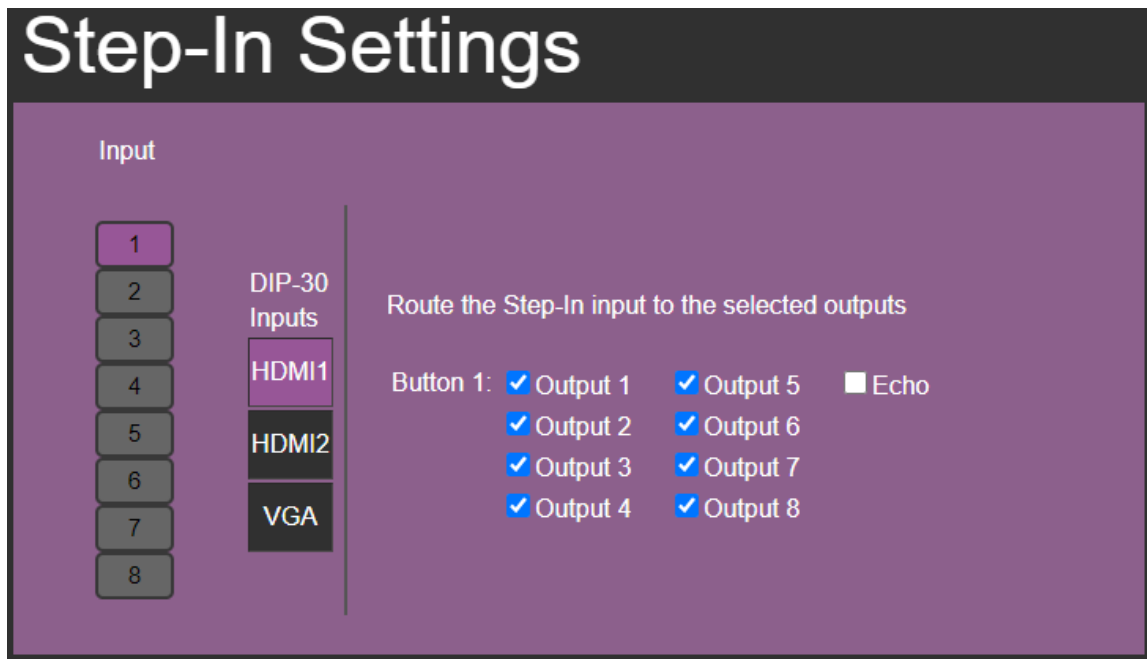

Figure 45: Step-In Settings Page – Step In Selected

- Select a **DIP-30** input (HDMI IN 1, HDMI IN 2 or VGA).
The respective button on **DIP-30** illuminates.



You can also press an input button on the **DIP-30**. The selected input will be displayed on the webpage.

- Check the outputs to which the inputs will be routed.
- Press the **STEP-IN** button on **DIP-30**.
The selected step-in button is routed to all the checked outputs.



Any time the output Step-in configuration changes, press the STEP-IN button on the Step-In device to update the configuration.



Selecting Echo sends an instruction via **VS-88H2A** RS-232 port.

Step-in device is controlled.

Managing EDID

The EDID Management page lets you perform the following functions:

- [Reading EDID from an Output](#) on page 49.
- [Reading Default EDID](#) on page 52.
- [Reading EDID from an Input](#) on page 52.
- [Reading EDID from a File](#) on page 53.

Reading EDID from an Output

To copy an EDID from an output to an input:

1. In the Navigation pane, click **EDID Management**. The EDID Management page appears.

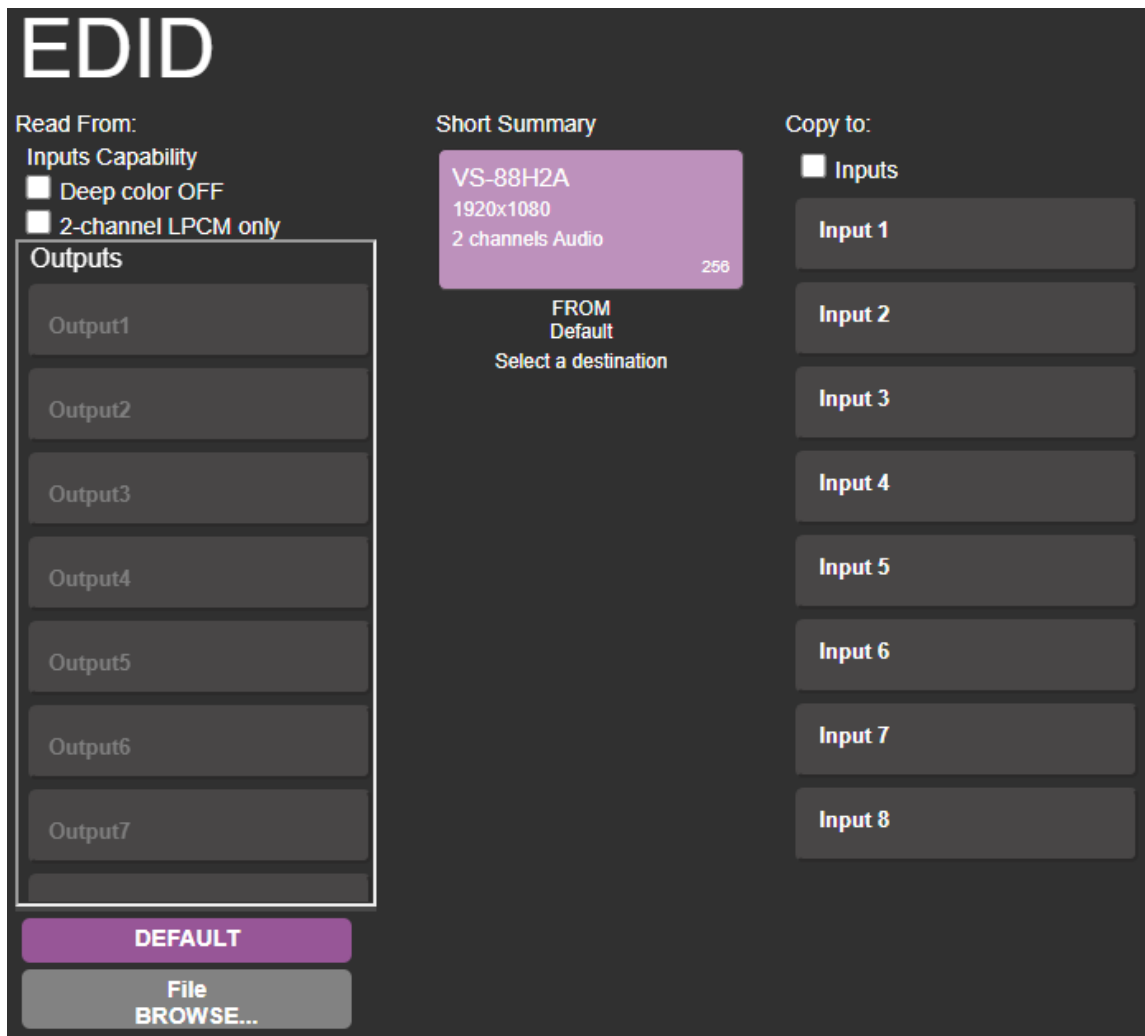

Figure 46: EDID Management Page – Select an EDID Source

2. Select the EDID source: a connected output.



When reading from an output, make sure that the output is connected to an acceptor.

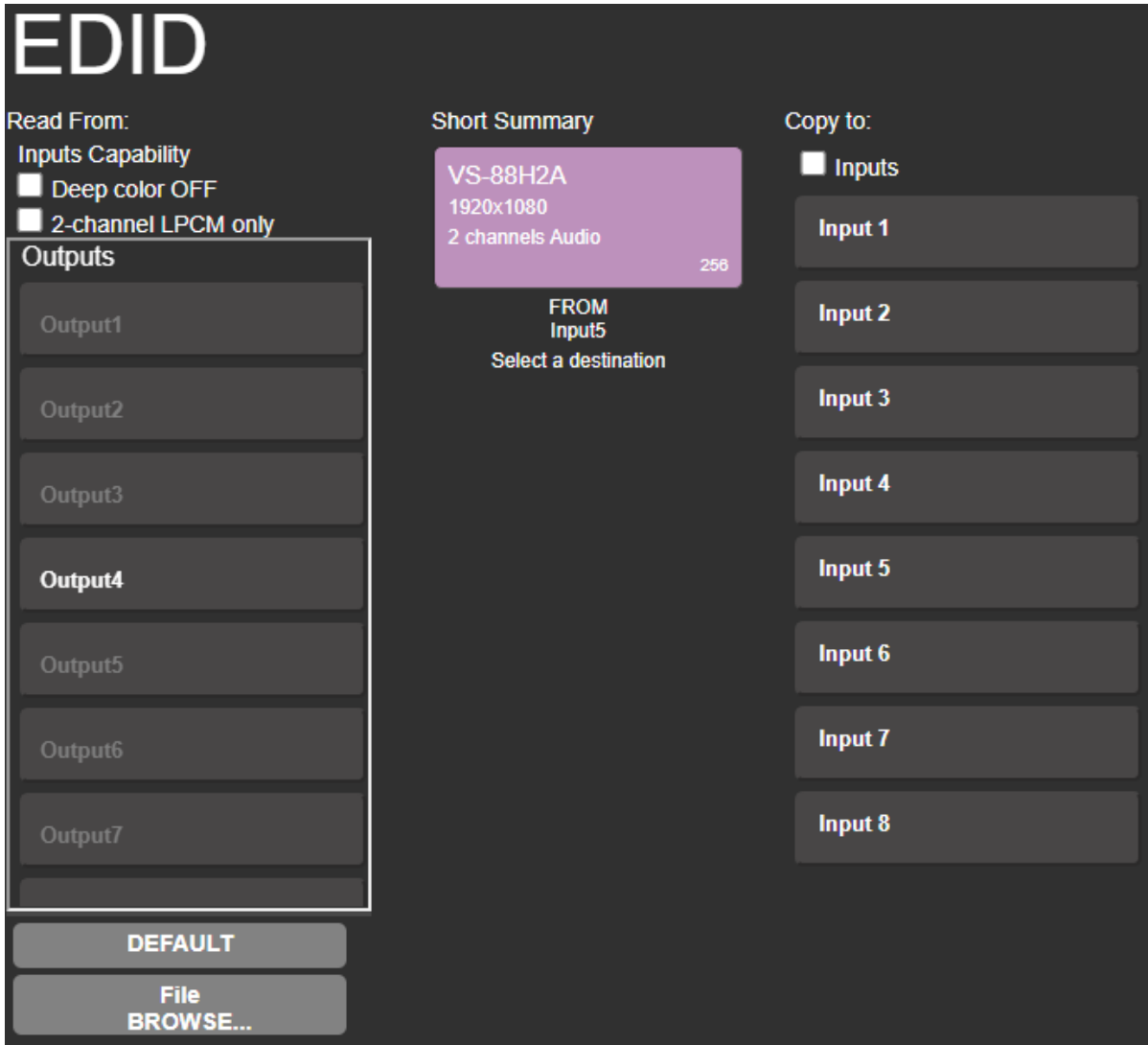

Figure 47: EDID Management Page – Select an EDID output

3. Select an input (or all the inputs) to which the EDID is copied.

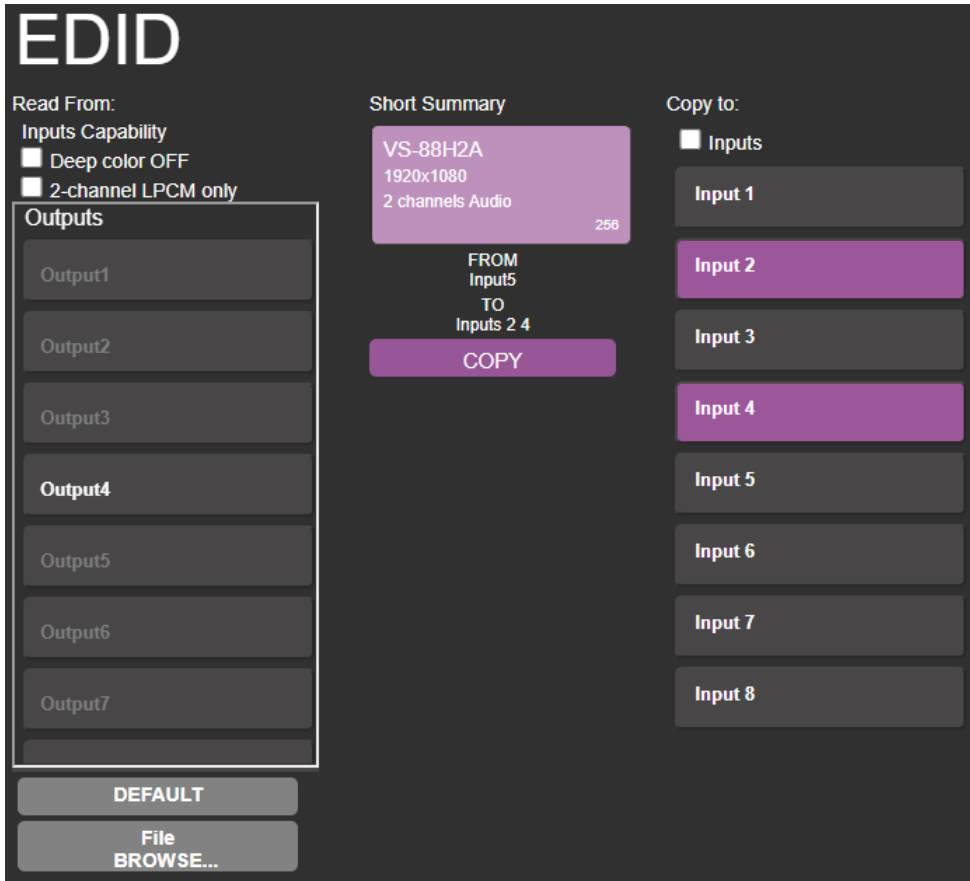

Figure 48: EDID Management Page – Select an Input

4. Click **COPY**.
The EDID message appears.

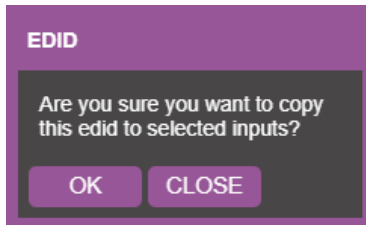

Figure 49: EDID Page –EDID Copy Message

5. Click **OK**. The following message appears:

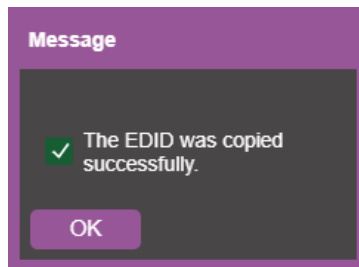

Figure 50: EDID Management Page – Loading the EDID from Output to Input

6. Click **OK**.

EDID is copied from a selected, connected output to the selected inputs.

Reading Default EDID

To read the EDID from the default EDID:

1. In the Navigation pane, click **EDID Management**. The EDID Management page appears.
2. Click **DEFAULT**.
3. Click **COPY**.
The EDID message appears.

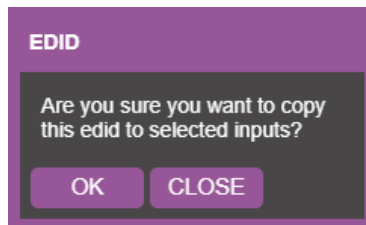

Figure 51: EDID Page –EDID Copy Message

4. Click **OK**. The following message appears:

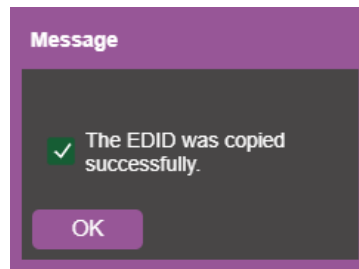

Figure 52: EDID Management Page – Loading the EDID from Output to Input

5. Click **OK**.
6. EDID is copied from a selected, connected output to the selected inputs.

Reading EDID from an Input

To read the EDID from an input to another input/s:

1. In the Navigation pane, click **EDID Management**. The EDID Management page appears.
2. Select an input from the list (on the left).

- If required, check the options under Inputs **Capabilities**.

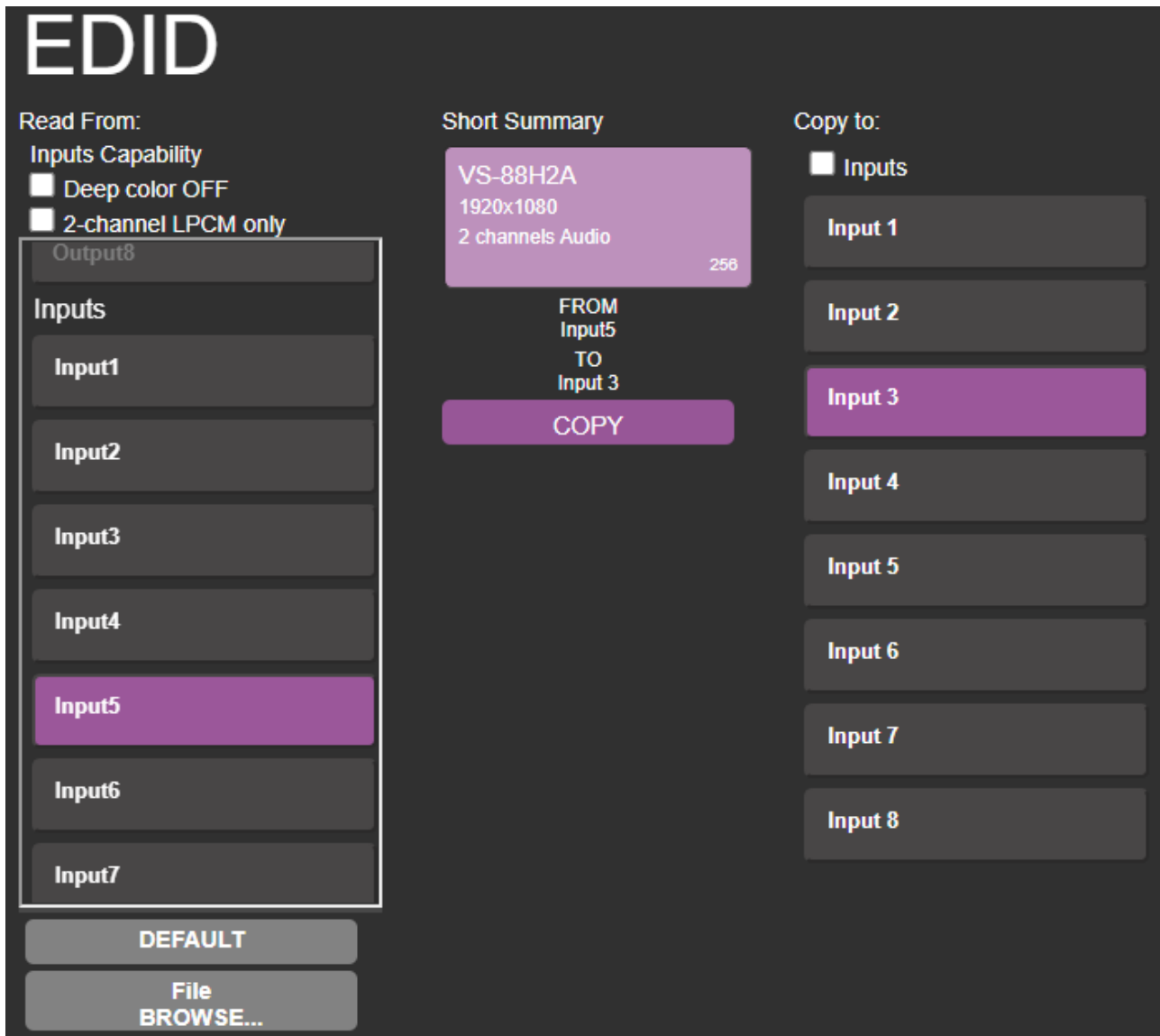

Figure 53: EDID Management Page – Loading the EDID from input to Input

- Click **COPY** and follow the instructions on-screen.

The EDID is read from an input to the selected inputs.

Reading EDID from a File

To read the EDID from a file:

- In the Navigation pane, click **EDID Management**. The EDID Management page appears.
- Click **File BROWSE** and open the EDID file.

3. Select an input/s.

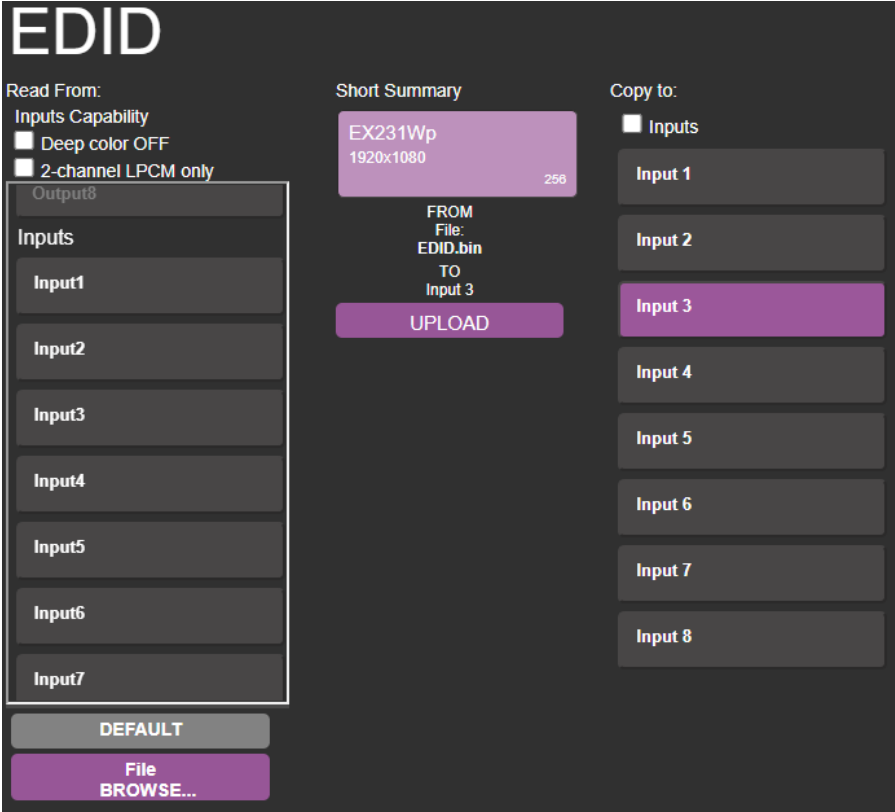

Figure 54: EDID Management Page – Loading the EDID from a File to the Input

4. Click **UPLOAD**. The following message appears:

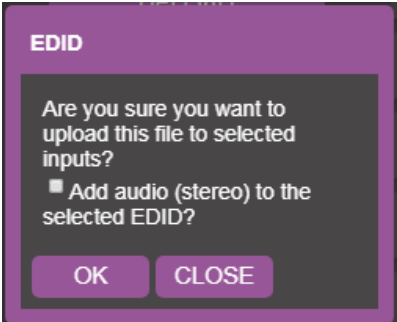

Figure 55: EDID Management Page – EDID Message

- 5. Click **OK**.
- 6. Follow the instructions on-screen.

EDID is copied from a file.



When viewing the 7-segment display in the EDID mode, the input with EDID read from a file will display “L”.

Viewing About Us Page

The VS-88H2A About page lets you view the webpage version and Kramer Electronics Ltd details.



Figure 56: About Page

Upgrading Firmware

Use the Kramer **K-UPLOAD** software to upgrade the firmware via the **VS-88H2A** PROG mini USB port (16), via the embedded webpages (see [Performing Firmware Upgrade](#) on page 39), or via Kramer Network.

The latest version of **K-UPLOAD** and installation instructions can be downloaded from our website at: www.kramerav.com/support/product_downloads.asp.



Note that in order to use the micro-USB port, you need to install the Kramer USB driver, available at: www.kramerav.com/support/product_downloads.asp.

Technical Specifications

Inputs	8 HDMI	On female HDMI connectors
	8 Stereo Analog Unbalanced Audio	On 3.5mm mini jacks
Outputs	8 HDMI	On female HDMI connectors
	8 Stereo Balanced Audio	On 5-pin terminal blocks (+4dBu nominal)
Ports	1 USB	On a mini-USB connector for firmware upgrade or communication (connecting to a PC or a serial controller)
	1 RS-232	On a 3-pin terminal block connector
	1 Ethernet	On an RJ-45 female connector for device control
	1 5V/2A USB	On a female USB-A connector for powering another device
Video	Max. Resolution	4K@60Hz (4:4:4)
	Compliance	Deep Color, 3D, ARC, up to 7.1 uncompressed audio channels as specified in HDMI 2.0; HDCP 2.2
Control	Front Panel	Front panel buttons for input/output selection, audio embedding, mute, test pattern, memory, EDID capture, factory reset and front panel lock.
	Indicators	7-segment display
Power	Consumption	66VA
	Source	100-240V AC, 50/60Hz
Environmental Conditions	Operating Temperature	0° to +40°C (32° to 104°F)
	Storage Temperature	-40° to +70°C (-40° to 158°F)
	Humidity	10% to 90%, RH non-condensing
General	Size	19", 7", 1U, rack mountable
	Net Dimensions (W, D, H)	43.6cm x 18.3cm x 4.4cm (17.18" x 7.20" x 1.72")
	Shipping Dimensions (W, D, H)	52.5cm x 33cm x 10.7cm (20.7" x 13" x 4.2")
	Net Weight	2.5kg (5.5lbs) approx.
	Shipping Weight	3.4kg (7.4lbs) approx.
Accessories	Included	Rack ears, power cord
Specifications are subject to change without notice at www.kramerav.com		

Default Communication Parameters

RS-232	
Baud Rate:	115,200
Data Bits:	8
Stop Bits:	1
Parity:	None
Command Format:	ASCII
Example (Route input 1 to output 1):	#VID1> 1<cr>
Ethernet	
To reset the IP settings to the factory reset values go to: Menu->Setup -> Factory Reset-> press Enter to confirm	
IP Address:	192.168.1.39
Subnet mask:	255.255.0.0
Default gateway:	192.168.0.1
Default TCP Port #:	5000
Default UDP Port #:	50000
Default username:	Admin
Default password:	Box left empty
Full Factory Reset	
OSD:	Front panel buttons: power off the device, press and hold the LOCK, EDID and STO buttons simultaneously for 3 seconds while powering the device, and then release.
Protocol 3000:	"#factory" command.
Web Pages:	In the Device Settings page, click Reset.

Input or Output Resolutions

VS-88H2A supports the following resolutions:

4096*2160P30	1080P23	1440*900P60	800*600P72
4096*2160P29	1080i60	1440*900P60rb	800*600P60
4096*2160P25	1080i59	1400*1050P75	800*600P56
4096*2160P24	1080i50	1400*1050P60	720*400P70
4096*2160P23	720P60	1400*1050P60rb	640*480P75
3840*2160P60	720P59	1366*768P60	640*480P72
3840*2160P30	720P50	1366*768P60rb	640*480P59
3840*2160P29	576P50	1360*768P60	680*480P60
3840*2160P25	576i50	1280*1024P60	1440*480I60
3840*2160P24	480P60	1280*960P60	1440*240P60
3840*2160P23	480P59	1280*768P60	1440*480P60
1080P60	480i60	1280*768P60rb	720*576P50
1080P59	480i59	1152*864P75	1440*576I50
1080P50	1920*1200P60rb	1024*768P75	1280*768P75
1080P30	1680*1050P60	1024*768P70	1280*800P60
1080P29	1680*1050P60rb	1024*768P60	1360*768P60
1080P25	1600*1200P60	848*480P60	1280*1024P75
1080P24	1600*900P60rb	800*600P75	

Default Parameters

Parameter	Value
Protocol:	K3000
K3000 Model Name:	V, 'S', '-', '8', '8', 'H', '2', 'A'
K3000 Serial Number:	00000000000000
 Model name and serial number will not change back to the default status after a factory reset.	
DHCP enable:	Disable(OFF)
EDID status:	Default, all input ports use the default EDID data.
Input port HDCP:	All ON, support HDCP.
Step-In button setting:	Default, all the output checked for an input.
Video status:	Output 1 to 8 route to input 1 to 8 separately.
Audio status:	Output 1 to 8 route to digital input 1 to 8 separately.
Output audio volume:	Default, 50.
Output audio balance:	Default, 50.
All setups:	All empty. No preset status.
EDID data:	All input ports use the default EDID data.
Switch mode:	Manual.
Switch speed:	Ex-fast switch.
ARC or de-embedded:	De-embedded.
Video Priority settings	Lower input index has higher priority.
Auto Switching mode	Priority: Priority order is Highest for 1 and lowest for 8
Auto Switching settings	All video inputs are routed to each of the video outputs
Default switching mode - manual/auto	Manual, IN1 to OUT1, etc for 2, to 8
Default EDID	Kramer default EDID with "monitor name"="VS-88UH2A"
Lock EDID state	Not locked
Video Signal loss timeout (no 5V)	0
Video Signal loss timeout (5V is on)	10 sec
New video signal gain timeout	0
Audio Signal loss timeout (no 5V)	0
Audio Signal loss timeout (5V is on)	5 sec
New audio signal gain timeout	0
Output inactivity timeout	15 min
Apply switch mode configuration on startup	10

Default EDID

```

Model name..... VS-88H2A
Manufacturer..... KMR
Plug and Play ID..... KMR03ED
Serial number..... 295-883450100
Manufacture date..... 2016, ISO week 20
Filter driver..... None
-----
EDID revision..... 1.3
Input signal type..... Digital
Color bit depth..... Undefined
Display type..... Monochrome/grayscale
Screen size..... 520 x 320 mm (24.0 in)
Power management..... Standby, Suspend, Active off/sleep
Extension blocs..... 1 (Reserved - 0x00)
-----
DDC/CI..... Not supported

Color characteristics
Default color space..... Non-sRGB
Display gamma..... 2.20
Red chromaticity..... Rx 0.674 - Ry 0.319
Green chromaticity..... Gx 0.188 - Gy 0.706
Blue chromaticity..... Bx 0.148 - By 0.064
White point (default).... Wx 0.313 - Wy 0.329
Additional descriptors... None

Timing characteristics
Horizontal scan range.... 30-83kHz
Vertical scan range..... 56-76Hz
Video bandwidth..... 170MHz
CVT standard..... Not supported
GTF standard..... Not supported
Additional descriptors... None
Preferred timing..... Yes
Native/preferred timing.. 1920x1080p at 60Hz (16:9)
Modeline..... "1920x1080" 148.500 1920 2008 2052 2200 1080 1084 1089 1125 +hsync +vsync

Standard timings supported
720 x 400p at 70Hz - IBM VGA
720 x 400p at 88Hz - IBM XGA2
640 x 480p at 60Hz - IBM VGA
640 x 480p at 67Hz - Apple Mac II
640 x 480p at 72Hz - VESA
640 x 480p at 75Hz - VESA
800 x 600p at 56Hz - VESA
800 x 600p at 60Hz - VESA
800 x 600p at 72Hz - VESA
800 x 600p at 75Hz - VESA
832 x 624p at 75Hz - Apple Mac II
1024 x 768i at 87Hz - IBM
1024 x 768p at 60Hz - VESA
1024 x 768p at 70Hz - VESA
1024 x 768p at 75Hz - VESA
1280 x 1024p at 75Hz - VESA
1152 x 870p at 75Hz - Apple Mac II
1280 x 1024p at 75Hz - VESA STD
1280 x 1024p at 85Hz - VESA STD
1600 x 1200p at 60Hz - VESA STD
1024 x 768p at 85Hz - VESA STD
800 x 600p at 85Hz - VESA STD
640 x 480p at 85Hz - VESA STD
1152 x 864p at 70Hz - VESA STD
1280 x 960p at 60Hz - VESA STD

Report information
Date generated..... 5/25/2021
Software revision..... 2.60.0.972
Data source..... Real-time 0xB700 - NB: improperly installed
Operating system..... 6.2.9200.2

Raw data
00,FF,FF,FF,FF,FF,FF,00,2D,B2,ED,03,01,00,00,00,14,1A,01,03,80,34,20,78,E2,B3,25,AC,51,30,B4,26,
10,50,54,FF,FF,80,81,8F,81,99,A9,40,61,59,45,59,31,59,71,4A,81,40,02,3A,80,18,71,38,2D,40,58,2C,
45,00,A0,5A,00,00,00,1E,00,00,00,FF,00,32,39,35,2D,38,38,33,34,35,30,31,30,30,00,00,00,FC,00,56,
53,2D,38,38,48,32,41,0A,20,20,20,20,00,00,00,FD,00,38,4C,1E,53,11,00,0A,20,20,20,20,20,01,9B

```

Monitor

Model name..... VM-10H2
 Manufacturer..... KMR
 Plug and Play ID..... KMR1200
 Serial number..... n/a
 Manufacture date..... 2016, ISO week 14
 Filter driver..... None

 EDID revision..... 1.3
 Input signal type..... Digital
 Color bit depth..... Undefined
 Display type..... Monochrome/grayscale
 Screen size..... 520 x 320 mm (24.0 in)
 Power management..... Standby, Suspend, Active off/sleep
 Extension blocs..... 1 (CEA-EXT(

 DDC/CI..... Not supported

Color characteristics

Default color space..... Non-sRGB
 Display gamma..... 2.20
 Red chromaticity..... Rx 0.674 - Ry 0.319
 Green chromaticity..... Gx 0.188 - Gy 0.706
 Blue chromaticity..... Bx 0.148 - By 0.064
 White point (default).... Wx 0.313 - Wy 0.329
 Additional descriptors... None

Timing characteristics

Horizontal scan range.... 30-83kHz
 Vertical scan range..... 56-76Hz
 Video bandwidth..... 170MHz
 CVT standard..... Not supported
 GTF standard..... Not supported
 Additional descriptors... Established timings
 Preferred timing..... Yes
 Native/preferred timing.. 1920x1080p at 60Hz
 Modeline..... "1920x1080" 148.500 1920 2008 2052 2200 1080 1084 1089 1125 +hsync +vsync

Standard timings supported

640 x 480p at 60Hz - IBM VGA
 640 x 480p at 72Hz - VESA
 640 x 480p at 75Hz - VESA
 800 x 600p at 60Hz - VESA
 800 x 600p at 72Hz - VESA
 800 x 600p at 75Hz - VESA
 1024 x 768p at 60Hz - VESA
 1024 x 768p at 70Hz - VESA
 1024 x 768p at 75Hz - VESA
 1280 x 1024p at 75Hz - VESA
 1600 x 900p at 60Hz - VESA STD
 1280 x 800p at 60Hz - VESA STD
 1600 x 1200p at 60Hz - VESA STD
 1024 x 768p at 85Hz - VESA STD
 800 x 600p at 85Hz - VESA STD
 640 x 480p at 85Hz - VESA STD
 1152 x 864p at 75Hz - VESA STD
 1280 x 960p at 60Hz - VESA STD
 848 x 480p at 60Hz - VESA
 1280 x 768p at 60Hz - VESA
 1280 x 1024p at 60Hz - VESA
 1360 x 768p at 60Hz - VESA
 1440 x 900p at 60Hz - VESA
 1400 x 1050p at 60Hz - VESA
 1650 x 1050p at 60Hz - VESA

EIA/CEA-861 Information

Revision number..... 3
 IT underscan..... Supported
 Basic audio..... Supported
 YCbCr 4:4:4..... Not supported
 YCbCr 4:2:2..... Not supported
 Native formats..... 1
 Detailed timing #1..... 720x480i at 30Hz
 Modeline..... "720x480" 8.490 720 808 857 981 480 488 498 570 interlace +hsync +vsync
 Detailed timing #2..... 852x480p at 60Hz (16:9)
 Modeline..... "852x480" 49.450 852 1380 1429 1572 480 484 489 525 +hsync +vsync
 Detailed timing #3..... 1366x768p at 50Hz (16:9)
 Modeline..... "1366x768" 84.650 1366 1894 1943 2086 768 772 777 813 +hsync +vsync
 Detailed timing #4..... 1366x768p at 60Hz (16:9)
 Modeline..... "1366x768" 101.610 1366 1894 1943 2086 768 772 777 813 +hsync +vsync
 Detailed timing #5..... 720x576p at 50Hz (4:3)
 Modeline..... "720x576" 27.370 720 728 841 880 576 578 596 621 -hsync -vsync

CE video identifiers (VICs) - timing/formats supported

1920 x 1080p at 60Hz - HDTV (16:9, 1:1) [Native]
 1920 x 1080i at 60Hz - HDTV (16:9, 1:1)
 720 x 480p at 60Hz - EDTV (4:3, 8:9)
 1920 x 1080i at 50Hz - HDTV (16:9, 1:1)
 1920 x 1080p at 50Hz - HDTV (16:9, 1:1)
 1920 x 1080p at 24Hz - HDTV (16:9, 1:1)
 1920 x 1080p at 30Hz - HDTV (16:9, 1:1)
 1920 x 1080p at 30Hz - HDTV (16:9, 1:1)
 1920 x 1080p at 30Hz - HDTV (16:9, 1:1)
 1920 x 1080p at 30Hz - HDTV (16:9, 1:1)
 1920 x 1080p at 30Hz - HDTV (16:9, 1:1)
 1920 x 1080p at 30Hz - HDTV (16:9, 1:1)
 1920 x 1080p at 30Hz - HDTV (16:9, 1:1)
 1920 x 1080p at 30Hz - HDTV (16:9, 1:1)
 1920 x 1080p at 30Hz - HDTV (16:9, 1:1)
 1920 x 1080p at 30Hz - HDTV (16:9, 1:1)
 1920 x 1080p at 30Hz - HDTV (16:9, 1:1)
 1920 x 1080p at 30Hz - HDTV (16:9, 1:1)
 1920 x 1080p at 30Hz - HDTV (16:9, 1:1)
 1920 x 1080p at 30Hz - HDTV (16:9, 1:1)
 NB: NTSC refresh rate = (Hz*1000)/1001

CE audio data (formats supported)

LPCM 2-channel, 16/20/24 bit depths at 32/44/48 kHz

CE speaker allocation data

Channel configuration.... 2.0
 Front left/right..... Yes
 Front LFE..... No
 Front center..... No
 Rear left/right..... No
 Rear center..... No
 Front left/right center.. No
 Rear left/right center... No
 Rear LFE..... No

CE vendor specific data (VSDB)

IEEE registration number. 0x000C03
 CEC physical address..... 1.0.0.3
 Maximum TMDS clock..... 165MHz

Report information

Date generated..... 19/02/2019
 Software revision..... 2.70.0.989
 Data source..... Real-time 0x0071
 Operating system..... 6.1.7601.2.Service Pack 1

Raw data

,00 FF,FF,FF,FF,FF,FF,00,2D,B2,00,12,00,00,00,00,0E,1A,01,03,80,34,20,78,E2,B3,25,AC,51,30,B4,26,
 10,50,54,2 D,CF,00,A9,C0,81,00,A9,40,61,59,45,59,31,59,71,4F,81,40,02,3A,80,18,71,38,2D,40,58,2C,
 45,00,0 F,24,21,00,00,1E,00,00,00,FD,00,38,4C,1E,53,11,00,0A,20,20,20,20,20,00,00,00,FC,00,56,
 4 D,2D,31,30,48,32,0A,20,20,20,20,00,00,00,F7,00,00,08,42,A2,20,00,00,00,00,00,00,01,AF,
 ,02,03,23 C1,50,90,05,02,14,1F,20,22,5D,5F,61,62,64,66,67,69,6B,23,09,07,07,83,01,00,00,65,03,0C,
 ,00,10,03,51,03 D0,05,21,F0,2D,00,58,31,45,00,0F,1A,21,00,00,9E,51,13,54,D0,32,E0,2D,10,10,31,45,
 ,80 BA,88,21,00,00,1E,11,21,56,D0,52,00,2D,30,10,31,45,80,BA,88,21,00,00,1E,B1,27,56,D0,52,00,2D,
 30,10,31,45,80,BA,88,21,00,00,1E,B1,0A,D0,A0,20,40,2D,20,08,71,22,01,80,E0,21,00,00,00,00,F1,CF

Protocol 3000

Kramer devices can be operated using Kramer Protocol 3000 commands sent via serial or Ethernet ports.

Understanding Protocol 3000

Protocol 3000 commands are a sequence of ASCII letters, structured according to the following.

- **Command format:**

Prefix	Command Name	Constant (Space)	Parameter(s)	Suffix
#	Command	_	Parameter	<CR>

- **Feedback format:**

Prefix	Device ID	Constant	Command Name	Parameter(s)	Suffix
~	nn	@	Command	Parameter	<CR><LF>

- **Command parameters** – Multiple parameters must be separated by a comma (,). In addition, multiple parameters can be grouped as a single parameter using brackets ([and]).
- **Command chain separator character** – Multiple commands can be chained in the same string. Each command is delimited by a pipe character (|).
- **Parameters attributes** – Parameters may contain multiple attributes. Attributes are indicated with pointy brackets (<...>) and must be separated by a period (.).

The command framing varies according to how you interface with **VS-88H2A**. The following figure displays how the # command is framed using terminal communication software (such as Hercules):

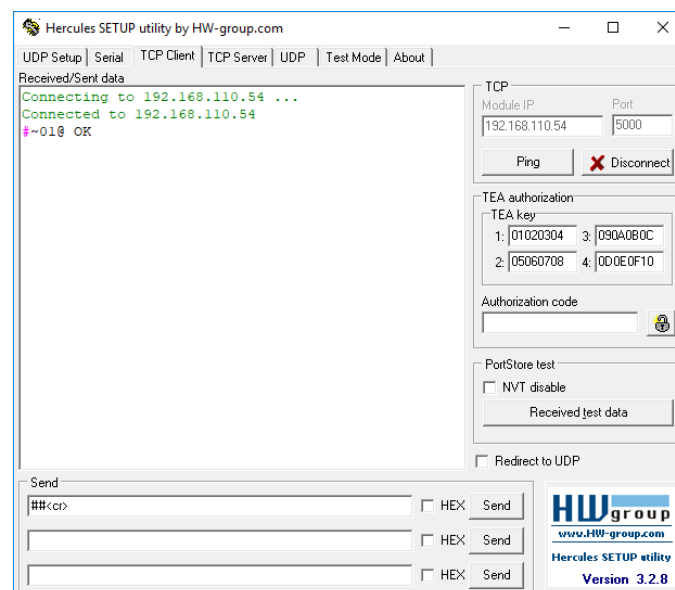

Protocol 3000 Commands

Function	Description	Syntax	Parameters/Attributes	Example
#	<p>Protocol handshaking.</p> <p>① Validates the Protocol 3000 connection and gets the machine number.</p> <p>Step-in master products use this command to identify the availability of a device.</p>	<p>COMMAND</p> <pre>#<CR></pre> <p>FEEDBACK</p> <pre>~nn@_ok<CR><LF></pre>		#<CR>
AFV	<p>Set audio follow video/audio breakaway mode.</p> <p>① When the unit moves from breakaway to audio follow video switching mode, all audio switch settings reset according to the video switch settings.</p>	<p>COMMAND</p> <pre>#AFV_afv_mode<CR></pre> <p>FEEDBACK</p> <pre>~nn@AFV_afv_mode<CR><LF></pre>	<p>afv_mode – Front panel AFV mode</p> <p>0 – afv – sets the unit to the audio-follow-video switching mode</p> <p>1 – brk – sets the unit to the audio breakaway switching mode</p>	<p>Set audio breakaway mode:</p> <pre>#AFV_1<CR></pre>
AFV?	<p>Get audio follow video mode status.</p> <p>① When the unit moves from breakaway to audio follow video switching mode, all audio switch settings reset according to the video switch settings.</p>	<p>COMMAND</p> <pre>#AFV?_<CR></pre> <p>FEEDBACK</p> <pre>~nn@AFV_afv_mode<CR><LF></pre>	<p>afv_mode – Front panel AFV mode</p> <p>0 – afv – sets the unit to the audio-follow-video switching mode</p> <p>1 – brk – sets the unit to the audio breakaway switching mode</p>	<p>Get audio follow video mode status:</p> <pre>#AFV?_<CR></pre>
AUD	<p>LEGACY COMMAND. Set audio switch state.</p> <p>① When AFV switching mode is active, this command cannot switch video.</p>	<p>COMMAND</p> <pre>#AUD_in>out_id,in>out_id,...<CR></pre> <p>FEEDBACK</p> <pre>~nn@AUD_in>out_id<CR><LF></pre> <pre>~nn@AUD_in>out_id<CR><LF></pre>	<p>in – Input number</p> <p>0 – disconnect output</p> <p>1 – HDMI IN 1</p> <p>2 – HDMI IN 2</p> <p>3 – HDMI IN 3</p> <p>4 – HDMI IN 4</p> <p>5 – HDMI IN 5</p> <p>6 – HDMI IN 6</p> <p>7 – HDMI IN 7</p> <p>8 – HDMI IN 8</p> <p>9 – Analog IN 1</p> <p>10 – Analog IN 2</p> <p>11 – Analog IN 3</p> <p>12 – Analog IN 4</p> <p>13 – Analog IN 5</p> <p>14 – Analog IN 6</p> <p>15 – Analog IN 7</p> <p>16 – Analog IN 8</p> <p>> – Connection character between in and out parameters</p> <p>out_id – Output number</p> <p>* – All outputs</p> <p>1 – HDMI OUT 1</p> <p>2 – HDMI OUT 2</p> <p>3 – HDMI OUT 3</p> <p>4 – HDMI OUT 4</p> <p>5 – HDMI OUT 5</p> <p>6 – HDMI OUT 6</p> <p>7 – HDMI OUT 7</p> <p>8 – HDMI OUT 8</p> <p>9 – Analog OUT 1</p> <p>10 – Analog OUT 2</p> <p>11 – Analog OUT 3</p> <p>12 – Analog OUT 4</p> <p>13 – Analog OUT 5</p> <p>14 – Analog OUT 6</p> <p>15 – Analog OUT 7</p> <p>16 – Analog OUT 8</p>	<p>Switch embedded audio HDMI IN 1 to HDMI OUT 3:</p> <pre>#AUD_1>3<CR></pre>

Function	Description	Syntax	Parameters/Attributes	Example
AUD?	LEGACY COMMAND. Get audio switch state. ⓘ When AFV switching mode is active, this command cannot switch video.	COMMAND #AUD?_out_id<CR> #AUD?_*<CR> FEEDBACK ~nn@AUD_in>out_id<CR><LF> ~nn@AUD_in>1,in>2,...<CR><LF>	in – Input number 1– HDMI IN 1 2– HDMI IN 2 3– HDMI IN 3 4– HDMI IN 4 5– HDMI IN 5 6– HDMI IN 6 7– HDMI IN 7 8– HDMI IN 8 9– Analog IN 1 10 – Analog IN 2 11 – Analog IN 3 12– Analog IN 4 13– Analog IN 5 14– Analog IN 6 15– Analog IN 7 16– Analog IN 8 > – Connection character between in and out parameters out_id – Output number * – All outputs 1– HDMI OUT 1 2– HDMI OUT 2 3– HDMI OUT 3 4– HDMI OUT 4 5– HDMI OUT 5 6– HDMI OUT 6 7– HDMI OUT 7 8– HDMI OUT 8 9– Analog OUT 1 10 – Analog OUT 2 11 – Analog OUT 3 12– Analog OUT 4 13– Analog OUT 5 14– Analog OUT 6 15– Analog OUT 7 16– Analog OUT 8	Get audio switch state for HDMI OUT 3: #AUD?_3<CR>
AV	Switch audio and video.	COMMAND #AV_in>out_id,in>out_id,...<CR> FEEDBACK ~nn@AV_in>out_id,in>out_id,...<CR><LF>	in – Number that indicates the specific input: 0– disconnect output 1– HDMI IN 1 2– HDMI IN 2 3– HDMI IN 3 4– HDMI IN 4 5– HDMI IN 5 6– HDMI IN 6 7– HDMI IN 7 8– HDMI IN 8 > – Connection character between in and out parameters out_id – Output number * – All outputs 1– HDMI OUT 1 2– HDMI OUT 2 3– HDMI OUT 3 4– HDMI OUT 4 5– HDMI OUT 5 6– HDMI OUT 6 7– HDMI OUT 7 8– HDMI OUT 8	Switch IN 1 to OUT 4: #AV_1>4<CR>
AV-SW-MODE	Set input auto switch mode (per output).	COMMAND #AV-SW-MODE_layer_type,out_index,connection_mode<CR> FEEDBACK ~nn@AV-SW-MODE_layer_type,out_index,connection_mode<CR><LF>	layer_type – Number that indicates the signal type: 1– Video out_index – Number that indicates the specific output: 1– HDMI OUT 1 2– HDMI OUT 2 3– HDMI OUT 3 4– HDMI OUT 4 5– HDMI OUT 5 6– HDMI OUT 6 7– HDMI OUT 7 8– HDMI OUT 8 connection_mode – Connection mode 0– manual 1– priority switch 2– last connected switch	Set input auto switch mode (per output) for HDMI 1 to manual: #AV-SW-MODE_1,1,0<CR>

Function	Description	Syntax	Parameters/Attributes	Example
AV-SW-MODE?	Get input auto switch mode (per output).	COMMAND #AV-SW-MODE?_layer_type,out_index<CR> FEEDBACK ~nn@AV-SW-MODE_layer_type,out_index,connection_mode<CR><LF>	layer_type – Number that indicates the signal type: 1 – Video out_index – Number that indicates the specific output: 1 – HDMI OUT 1 2 – HDMI OUT 2 3 – HDMI OUT 3 4 – HDMI OUT 4 5 – HDMI OUT 5 6 – HDMI OUT 6 7 – HDMI OUT 7 8 – HDMI OUT 8 connection_mode – Connection mode 0 – manual 1 – priority switch 2 – last connected switch	Get the input audio switch mode for HDMI Out: #AV-SW-MODE?_1,1<CR>
AV-SW-TIMEOUT	Set auto switching timeout.	COMMAND #AV-SW-TIMEOUT_switching_mode,time_out<CR> FEEDBACK ~nn@AV-SW-TIMEOUT_switching_mode,time_out<CR><LF>	switching_mode – Switching mode 0 – Video signal lost 4 – Disable 5V on video output if no input signal detected time_out – Timeout in seconds 0 - 999	Set the auto switching timeout to 5 seconds in the event of 5V disable when no input signal is detected: #AV-SW-TIMEOUT_4,5<CR>
AV-SW-TIMEOUT?	Get auto switching timeout.	COMMAND #AV-SW-TIMEOUT?_switching_mode<CR> FEEDBACK ~nn@AV-SW-TIMEOUT_switching_mode,time_out<CR><LF>	switching_mode – Switching mode 0 – Video signal lost 4 – Disable 5V on video output if no input signal detected time_out – Timeout in seconds 0 - 999	Get the Disable 5V on video output if no input signal detected timeout: #AV-SW-TIMEOUT?_4<CR>
BALANCE	Set balance level.	COMMAND #BALANCE_out_index,balance_level<CR> FEEDBACK ~nn@BALANCE_out_index,balance_level<CR><LF>	out_index – Number that indicates the specific output: 1 – Analog OUT 1 2 – Analog OUT 2 3 – Analog OUT 3 4 – Analog OUT 4 5 – Analog OUT 5 6 – Analog OUT 6 7 – Analog OUT 7 8 – Analog OUT 8 balance_level – 0 to 100; ++ increase current value – decrease current value	Set the speaker output balance to +12: #BALANCE_1,12<CR>
BALANCE?	Get balance level.	COMMAND #BALANCE?_out_index<CR> FEEDBACK ~nn@BALANCE_out_index,balance_level<CR><LF>	out_index – Number that indicates the specific output: 1 – Analog OUT 1 2 – Analog OUT 2 3 – Analog OUT 3 4 – Analog OUT 4 5 – Analog OUT 5 6 – Analog OUT 6 7 – Analog OUT 7 8 – Analog OUT 8 balance_level – 0 to 100 ++ increase current value – decrease current value	Get balance level for channel 1: #BALANCE?_1<CR>
BAUD	Set protocol serial port baud rate. ⓘ The new defined baud rate is stored in the EEPROM and used when powering up. Default baud rate is 115200 (on factory reset). Only works with devices supporting this command (if ERR 002 is returned, the default baud rate is used).	COMMAND #BAUD_baud_rate<CR> FEEDBACK ~nn@BAUD_baud_rate<CR><LF> Option 1: ~nn@BAUD_current_baud_rate<CR><LF> Option 2: ~nn@BAUD_baud_rate1,baud_rate2,...<CR><LF>	baud_rate – 9600 / 115200 / else - new baud rate to set current_baud_rate – 9600 / 115200 / else - current protocol serial port baud rate baud_param – 0 - get the list of supported baud rates baud_rate1,baud_rate2,... – List of supported baud rates	Set the baud rate to 9600: #BAUD_9600<CR>
BAUD?	Get protocol serial port baud rate. (Option 1 - for current baud rate. Option 2 - for list of supported baud rates). ⓘ The new defined baud rate is stored in the EEPROM and used when powering up. Default baud rate is 115200 (on factory reset). Only works with devices supporting this command (if ERR 002 is returned, the default baud rate is used).	COMMAND #BAUD?_<CR> #BAUD?_baud_param<CR> FEEDBACK ~nn@BAUD_baud_rate<CR><LF> Option 1: ~nn@BAUD_current_baud_rate<CR><LF> Option 2: ~nn@BAUD_baud_rate1,baud_rate2,...<CR><LF>	baud_rate – 9600 / 115200 / else - new baud rate to set current_baud_rate – 9600 / 115200 / else - current protocol serial port baud rate baud_param – 0 - get the list of supported baud rates baud_rate1, - Baud_rate2, ... - list of supported baud rates	Get protocol serial port baud rate: #BAUD?_<CR>

Function	Description	Syntax	Parameters/Attributes	Example
BUILD-DATE?	Get device build date.	COMMAND #BUILD-DATE?_<CR> FEEDBACK ~nn@BUILD-DATE_date,time<CR><LF>	date – Format: YYYY/MM/DD where YYYY = Year MM = Month DD = Day time – Format: hh:mm:ss where hh = hours mm = minutes ss = seconds	Get the device build date: #BUILD-DATE?<CR>
CPEDID	Copy EDID data from the output to the input EEPROM. ⓘ Destination bitmap size depends on device properties (for 64 inputs it is a 64-bit word). Example: bitmap 0x0013 means inputs 1,2 and 5 are loaded with the new EDID. In certain products Safe_mode is an optional parameter. See the HELP command for its availability.	COMMAND #CPEDID_edid_io,src_id,dst_type,dest_bitmap<CR> or #CPEDID_edid_io,src_id,dst_type,dest_bitmap,safe_mode<CR> FEEDBACK ~nn@CPEDID_edid_io,src_id,dst_type,dest_bitmap<CR><LF> ~nn@CPEDID_edid_io,src_id,dst_type,dest_bitmap,safe_mode<CR><LF>	edid_io – EDID source type (usually output) 0 – Input 1 – Output 2 – Default EDID src_id – Number of chosen source stage For input source: 1 – HDMI IN 1 2 – HDMI IN 2 3 – HDMI IN 3 4 – HDMI IN 4 5 – HDMI IN 5 6 – HDMI IN 6 7 – HDMI IN 7 8 – HDMI IN 8 For output source: 0 – Default EDID source 1 – HDMI OUT 1 2 – HDMI OUT 2 3 – HDMI OUT 3 4 – HDMI OUT 4 5 – HDMI OUT 5 6 – HDMI OUT 6 7 – HDMI OUT 7 8 – HDMI OUT 8 dst_type – EDID destination type (usually input) 0 – Input dest_bitmap – Bitmap representing destination IDs. Format: XXXX..X, where X is hex digit. The binary form of every hex digit represents corresponding destinations. 0 – indicates that EDID data is not copied to this destination. 1 – indicates that EDID data is copied to this destination. safe_mode – Safe mode 0 – device accepts the EDID as is without trying to adjust 1 – device tries to adjust the EDID (default value if no parameter is sent)	Copy the EDID data from the Output 1 (EDID source) to the Input: #CPEDID_1,1,0,0x1<CR> Copy the EDID data from the default EDID source to the Input: #CPEDID_2,0,0,0x1<CR>
DIR	List files in device.	COMMAND #DIR<CR> FEEDBACK Multi-line: ~nn@DIR<CR><LF> file_name TABfile_size_bytes,id:_file_id<CR><LF> TABfree_size_bytes.<CR><LF>	file_name – Name of file file_size – File size in bytes. A file can take more space on device memory file_id – Internal ID for file in file system free_size – Free space in bytes in device file system	#DIR<CR>
DISPLAY?	Get output HPD status.	COMMAND #DISPLAY?_out_index<CR> FEEDBACK ~nn@DISPLAY_out_index,status<CR><LF>	out_index – Number that indicates the specific output: 1 – HDMI OUT 1 2 – HDMI OUT 2 3 – HDMI OUT 3 4 – HDMI OUT 4 5 – HDMI OUT 5 6 – HDMI OUT 6 7 – HDMI OUT 7 8 – HDMI OUT 8 status – HPD status according to signal validation 0 – Signal or sink is not valid 1 – Signal or sink is valid 2 – Sink and EDID is valid	Get the output HPD status of HDMI OUT 1: #DISPLAY?_1<CR>
DPSW-STATUS? N/A	Get the DIP-switch state.	COMMAND #DPSW-STATUS?_dip_id<CR> FEEDBACK ~nn@DPSW-STATUS_dip_id,status<CR><LF>	dip_id – 1 to 8 (number of DIP switches) status – Up/down 0 – Up 1 – Down	get the DIP-switch 2 status: #DPSW-STATUS?_2<CR>
ETH-PORT	Set Ethernet port protocol. ⓘ If the port number you enter is already in use, an error is returned. The port number must be within the following range: 0-(2 ¹⁶ -1).	COMMAND #ETH-PORT_port_type,port_id<CR> FEEDBACK ~nn@ETH-PORT_port_type,port_id<CR><LF>	port_type – TCP/UDP port_id – TCP/UDP port number (2000 – 65535)	Set the Ethernet port protocol for TCP to port 12457: #ETH-PORT_0,12457<CR>

Function	Description	Syntax	Parameters/Attributes	Example
ETH-PORT?	Get Ethernet port protocol.	COMMAND #ETH-PORT?_port_type<CR> FEEDBACK ~nn@ETH-PORT,_port_type,port_id<CR><LF>	port_type – TCP/UDP 0 – TCP 1 – UDP port_id – TCP / UDP port number (2000 – 65535)	Get the Ethernet port protocol for UDP: #ETH-PORT?_i<CR>
FACTORY	Reset device to factory default configuration. ⓘ This command deletes all user data from the device. The deletion can take some time. Your device may require powering off and powering on for the changes to take effect.	COMMAND #FACTORY<CR> FEEDBACK ~nn@FACTORY_ok<CR><LF>		Reset the device to factory default configuration: #FACTORY<CR>
FPGA-VER?	Get current FPGA version.	COMMAND #FPGA-VER?_fpga_id<CR> FEEDBACK ~nn@FPGA-VER,_fpga_id,expected_ver,ver<CR><LF>	fpga_id – FPGA id 1 expected_ver – Expected FPGA version for current firmware ver – Actual FPGA version	Get current FPGA version: #FPGA-VER?_i<CR>
GEDID	Get EDID support on certain input/output. ⓘ For old devices that do not support this command, ~nn@ERR 002<CR><LF> is received.	COMMAND #GEDID_io_mode,in_index<CR> FEEDBACK ~nn@GEDID_io_mode,in_index,size<CR><LF>	io_mode – Input/Output 0 – Input 1 – Output 2 – Default EDID in_index – Number that indicates the specific input: 1 – HDMI IN 1 2 – HDMI IN 2 3 – HDMI IN 3 4 – HDMI IN 4 5 – HDMI IN 5 6 – HDMI IN 6 7 – HDMI IN 7 8 – HDMI IN 8 size – Size of data to be sent from device, 0 means no EDID support	Get EDID support information for input 1: #GEDID_0,1<CR>
HDCP-MOD	Set HDCP mode. ⓘ Set HDCP working mode on the device input: HDCP supported - HDCP_ON [default]. HDCP not supported - HDCP OFF.	COMMAND #HDCP-MOD_in_index,mode<CR> FEEDBACK ~nn@HDCP-MOD_in_index,mode<CR><LF>	in_index – Number that indicates the specific input: 1 – HDMI IN 1 2 – HDMI IN 2 3 – HDMI IN 3 4 – HDMI IN 4 5 – HDMI IN 5 6 – HDMI IN 6 7 – HDMI IN 7 8 – HDMI IN 8 mode – HDCP mode: 0 – HDCP Off 1 – HDCP On	Set the input HDCP-MODE of HDMI IN 1 to Off: #HDCP-MOD_1,0<CR>
HDCP-MOD?	Get HDCP mode. ⓘ Set HDCP working mode on the device input: HDCP supported - HDCP_ON [default]. HDCP not supported - HDCP OFF.	COMMAND #HDCP-MOD?_in_index<CR> FEEDBACK ~nn@HDCP-MOD_in_index,mode<CR><LF>	in_index – Number that indicates the specific input: 1 – HDMI IN 1 2 – HDMI IN 2 3 – HDMI IN 3 4 – HDMI IN 4 5 – HDMI IN 5 6 – HDMI IN 6 7 – HDMI IN 7 8 – HDMI IN 8 mode – HDCP mode: 0 – HDCP Off 1 – HDCP On	Get the input HDCP-MODE of HDMI IN 1: #HDCP-MOD?_i<CR>
HDCP-STAT?	Get HDCP signal status. ⓘ io_mode =1 – get the HDCP signal status of the sink device connected to the specified output. io_mode =0 – get the HDCP signal status of the source device connected to the specified input.	COMMAND #HDCP-STAT?_io_mode,in_index<CR> FEEDBACK ~nn@HDCP-STAT_io_mode,in_index,status<CR><LF>	io_mode – Input/Output 0 – Input 1 – Output in_index – Number that indicates the specific input: 1 – HDMI IN 1 2 – HDMI IN 2 3 – HDMI IN 3 4 – HDMI IN 4 5 – HDMI IN 5 6 – HDMI IN 6 7 – HDMI IN 7 8 – HDMI IN 8 status – Signal encryption status - valid values On/Off 0 – HDCP Off 1 – HDCP On	Get the output HDCP-STATUS of HDMI IN 1: #HDCP-STAT?_0,1<CR>
HELP	Get command list or help for specific command.	COMMAND #HELP<CR> FEEDBACK 1. Multi-line: ~nn@Device_cmd_name,_cmd_name...<CR><LF>	cmd_name – Name of a specific command	Get the command list: #HELP<CR>

Function	Description	Syntax	Parameters/Attributes	Example
IDV	Set visual indication from device. ⓘ Using this command, some devices can light a sequence of buttons or LEDs to allow identification of a specific device from similar devices.	COMMAND #IDV<CR> FEEDBACK ~nn@IDV_ok<CR><LF>		#IDV<CR>
INFO-IO?	LEGACY COMMAND. Get in/out count.	COMMAND #INFO-IO?_<CR> FEEDBACK ~nn@INFO-IO_IN_in_count,OUT_out_count<CR><LF>	in_count – Number of inputs in the unit out_count – Number of outputs in the unit	Get inputs count: #INFO-IO?_<CR>
INFO-PRST?	LEGACY COMMAND. Get maximum preset count. ⓘ In most units, video and audio presets with the same number are stored and recalled together by commands #PRST-STO and #PRST-RCL.	COMMAND #INFO-PRST?_<CR> FEEDBACK ~nn@INFO-PRST_vid_video_preset_count,aud_audio_preset_count<CR><LF>	video_preset_count – Maximum number of video presets in the unit audio_preset_count – Maximum number of audio presets in the unit	Get number of video and audio presets: #INFO-PRST?_<CR>
LABEL	Set input/output label.	COMMAND #LABEL_io_mode,io_index,switch,label_txt<CR> FEEDBACK ~nn@LABEL_io_mode,io_index,switch,label_txt<CR><LF>	io_mode – Input/Output 0 – Input 1 – Output io_index – Number that indicates the specific input or output port: 1 – HDMI IN 1 2 – HDMI IN 2 3 – HDMI IN 3 4 – HDMI IN 4 5 – HDMI IN 5 6 – HDMI IN 6 7 – HDMI IN 7 8 – HDMI IN 8 1 – HDMI OUT 1 2 – HDMI OUT 2 3 – HDMI OUT 3 4 – HDMI OUT 4 5 – HDMI OUT 5 6 – HDMI OUT 6 7 – HDMI OUT 7 8 – HDMI OUT 8 switch – On/Off (enable/disable) custom label label_txt – Custom label string	Set input/output label: #LABEL_1,1,1,1<CR>
LABEL?	Get input/output label.	COMMAND #LABEL?_io_mode,io_index<CR> FEEDBACK ~nn@LABEL_io_mode,io_index,switch,label_txt<CR><LF>	io_mode – Input/Output 0 – Input 1 – Output io_index – Number that indicates the specific input or output port: 1 – HDMI IN 1 2 – HDMI IN 2 3 – HDMI IN 3 4 – HDMI IN 4 5 – HDMI IN 5 6 – HDMI IN 6 7 – HDMI IN 7 8 – HDMI IN 8 1 – HDMI OUT 1 2 – HDMI OUT 2 3 – HDMI OUT 3 4 – HDMI OUT 4 5 – HDMI OUT 5 6 – HDMI OUT 6 7 – HDMI OUT 7 8 – HDMI OUT 8 switch – On/Off (enable/disable) custom label label_txt – Custom label string	Get input/output label: #LABEL?_0,1<CR>

Function	Description	Syntax	Parameters/Attributes	Example										
LOAD	Load file to device.	<p>COMMAND #LOAD_file_name,size<CR></p> <p>FEEDBACK Data sending negotiation: * Device - ~01@LOAD_file_name,size_ready<CR><LF></p> <p>* End User (+Device)- Send file in Protocol Packets * Device - ~01@LOAD_file_name,size_ok<CR><LF></p>	<p>file_name – Name of file to save on device size – Size of file data that is sent</p> <p>Using the Packet Protocol Send a command: LDRV, LOAD, IROUT, LDEDID Receive Ready or ERR### If Ready: a. Send a packet, b. Receive OK on the last packet, c. Receive OK for the command</p> <p>Packet structure: Packet ID (1, 2, 3...) (2 bytes in length) Length (data length + 2 for CRC) – (2 bytes in length) Data (data length -2 bytes) CRC – 2 bytes</p> <table border="1"> <tr> <td>01</td> <td>02</td> <td>03</td> <td>04</td> <td>05</td> </tr> <tr> <td>Packet ID</td> <td>Length</td> <td>Data</td> <td>CRC</td> <td></td> </tr> </table> <p>5. Response: ~nnnn_ok<CR><LF> (Where NNNN is the received packet ID in ASCII hex digits.)</p>	01	02	03	04	05	Packet ID	Length	Data	CRC		Load the file_response.dat file to the device: #LOAD_file_response.dat,5360<CR>
01	02	03	04	05										
Packet ID	Length	Data	CRC											
LOCK-FP	Lock the front panel.	<p>COMMAND #LOCK-FP_lock/unlock<CR></p> <p>FEEDBACK ~nn@LOCK-FP_lock/unlock<CR><LF></p>	<p>lock/unlock – On/Off 0 – Off unlocks EDID 1 – On locks EDID</p>	Unlock front panel: #LOCK-FP_0<CR>										
LOCK-FP?	Get the front panel lock state.	<p>COMMAND #LOCK-FP?_<CR></p> <p>FEEDBACK ~nn@LOCK-FP_lock/unlock<CR><LF></p>	<p>lock/unlock – On/Off 0 – Off unlocks EDID 1 – On locks EDID</p>	Get the front panel lock state: #LOCK-FP?<CR>										
LOGIN	<p>Set protocol permission.</p> <p> The permission system works only if security is enabled with the "SECUR" command.</p> <p>LOGIN allows the user to run commands with an End User or Administrator permission level. When the permission system is enabled, LOGIN enables running commands with the User or Administrator permission level. When set, login must be performed upon each connection</p> <p>It is not mandatory to enable the permission system in order to use the device</p> <p>In each device, some connections allow logging in to different levels. Some do not work with security at all.</p> <p>Connection may logout after timeout.</p>	<p>COMMAND #LOGIN_login_level,password<CR></p> <p>FEEDBACK ~nn@LOGIN_login_level,password_ok<CR><LF></p> <p>or ~nn@LOGIN_err_004<CR><LF></p> <p>(if bad password entered)</p>	<p>login_level – Level of permissions required (User or Admin) password – Predefined password (by PASS command). Default password is an empty string</p>	Set the protocol permission level to Admin (when the password defined in the PASS command is 33333): #LOGIN_admin,33333<CR>										

Function	Description	Syntax	Parameters/Attributes	Example
LOGIN?	<p>Get current protocol permission level.</p> <p>i The permission system works only if security is enabled with the "SECUR" command.</p> <p>For devices that support security, LOGIN allows the user to run commands with an End User or Administrator permission level.</p> <p>In each device, some connections allow logging in to different levels. Some do not work with security at all.</p> <p>Connection may logout after timeout.</p>	<p>COMMAND</p> <pre>#LOGIN?_<CR></pre> <p>FEEDBACK</p> <pre>~nn@LOGIN_<login_level><CR><LF></pre>	<p>login_level – Level of permissions required (User or Admin)</p>	<p>Get current protocol permission level:</p> <pre>#LOGIN?_<CR></pre>
LOGOUT	<p>Cancel current permission level.</p> <p>i Logs out from End User or Administrator permission levels to Not Secure.</p>	<p>COMMAND</p> <pre>#LOGOUT<CR></pre> <p>FEEDBACK</p> <pre>~nn@LOGOUT_<ok><CR><LF></pre>		<pre>#LOGOUT<CR></pre>
MODEL?	<p>Get device model.</p> <p>i This command identifies equipment connected to VS-88H2A and notifies of identity changes to the connected equipment. The Matrix saves this data in memory to answer REMOTE-INFO requests.</p>	<p>COMMAND</p> <pre>#MODEL?_<CR></pre> <p>FEEDBACK</p> <pre>~nn@MODEL_<model_name><CR><LF></pre>	<p>model_name – String of up to 19 printable ASCII chars</p>	<p>Get the device model:</p> <pre>#MODEL?_<CR></pre>
MTX-MODE	<p>LEGACY COMMAND. Set auto-switch mode.</p> <p>i Not recommended for new devices.</p>	<p>COMMAND</p> <pre>#MTX-MODE_<out_id>,<connection_mode><CR></pre> <p>FEEDBACK</p> <pre>~nn@MTX-MODE_<out_id>,<connection_mode><CR><LF></pre>	<p>out_id – number of system outputs</p> <ul style="list-style-type: none"> * – All outputs 1 – HDMI OUT 1 2 – HDMI OUT 2 3 – HDMI OUT 3 4 – HDMI OUT 4 5 – HDMI OUT 5 6 – HDMI OUT 6 7 – HDMI OUT 7 8 – HDMI OUT 8 <p>connection_mode – Connection mode</p> <ul style="list-style-type: none"> 0 – manual 1 – auto priority 2 – auto last connected 	<p>Set output to last connected:</p> <pre>#MTX-MODE_<1,2><CR></pre>
MTX-MODE?	<p>LEGACY COMMAND. Get auto-switch mode.</p> <p>i Not recommended for new devices.</p>	<p>COMMAND</p> <pre>#MTX-MODE?_<out_id><CR></pre> <p>FEEDBACK</p> <pre>~nn@MTX-MODE_<out_id>,<connection_mode><CR><LF></pre>	<p>out_id – number of system outputs</p> <ul style="list-style-type: none"> 1 – HDMI OUT 1 2 – HDMI OUT 2 3 – HDMI OUT 3 4 – HDMI OUT 4 5 – HDMI OUT 5 6 – HDMI OUT 6 7 – HDMI OUT 7 8 – HDMI OUT 8 <p>connection_mode – Connection mode</p> <ul style="list-style-type: none"> 0 – manual 1 – auto priority 2 – auto last connected 	<p>Get auto-switch mode:</p> <pre>#MTX-MODE?_<2><CR></pre>
MUTE	<p>Set audio mute.</p>	<p>COMMAND</p> <pre>#MUTE_<out_index>,<mute_mode><CR></pre> <p>FEEDBACK</p> <pre>~nn@MUTE_<out_index>,<mute_mode><CR><LF></pre>	<p>out_index – Number that indicates the specific output:</p> <ul style="list-style-type: none"> 1 – Analog OUT 1 2 – Analog OUT 2 3 – Analog OUT 3 4 – Analog OUT 4 5 – Analog OUT 5 6 – Analog OUT 6 7 – Analog OUT 7 8 – Analog OUT 8 <p>mute_mode – On/Off</p> <ul style="list-style-type: none"> 0 – Off 1 – On 	<p>Set Output 1 to mute:</p> <pre>#MUTE_<1,1><CR></pre>

Function	Description	Syntax	Parameters/Attributes	Example
MUTE?	Get audio mute.	COMMAND #MUTE?_out_index<CR> FEEDBACK ~nn@MUTE_out_index,mute_mode<CR><LF>	out_index – Number that indicates the specific output: 1 – Analog OUT 1 2 – Analog OUT 2 3 – Analog OUT 3 4 – Analog OUT 4 5 – Analog OUT 5 6 – Analog OUT 6 7 – Analog OUT 7 8 – Analog OUT 8 mute_mode – On/Off 0 – Off 1 – On	Get mute status of output 1 #MUTE_1?<CR>
NAME	Set machine (DNS) name. <i>i</i> The machine name is not the same as the model name. The machine name is used to identify a specific machine or a network in use (with DNS feature on).	COMMAND #NAME_machine_name<CR> FEEDBACK ~nn@NAME_machine_name<CR><LF>	machine_name – String of up to 14 alpha-numeric chars (can include hyphen, not at the beginning or end)	Set the DNS name of the device to room-442: #NAME_room-442<CR>
NAME?	Get machine (DNS) name. <i>i</i> The machine name is not the same as the model name. The machine name is used to identify a specific machine or a network in use (with DNS feature on).	COMMAND #NAME?_<CR> FEEDBACK ~nn@NAME_machine_name<CR><LF>	machine_name – String of up to 14 alpha-numeric chars (can include hyphen, not at the beginning or end)	Get the DNS name of the device: #NAME?_<CR>
NAME-RST	Reset machine (DNS) name to factory default. <i>i</i> Factory default of machine (DNS) name is "KRAMER_" + 4 last digits of device serial number.	COMMAND #NAME-RST<CR> FEEDBACK ~nn@NAME-RST_ok<CR><LF>		Reset the machine name (S/N last digits are 0102): #NAME-RST_kramer_0102<CR>
NET-DHCP	Set DHCP mode. <i>i</i> Only 1 is relevant for the mode value. To disable DHCP, the user must configure a static IP address for the device. Connecting Ethernet to devices with DHCP may take more time in some networks. To connect with a randomly assigned IP by DHCP, specify the device DNS name (if available) using the NAME command. You can also get an assigned IP by direct connection to USB or RS-232 protocol port, if available. For proper settings consult your network administrator. <i>i</i> For Backward compatibility, the id parameter can be omitted. In this case, the Network ID, by default, is 0, which is the Ethernet control port.	COMMAND #NET-DHCP_dhcp_state<CR> FEEDBACK ~nn@NET-DHCP_dhcp_state<CR><LF>	dhcp_state – 1 – Try to use DHCP. (If unavailable, use the IP address set by the factory or the net-ip command).	Enable DHCP mode for port 1, if available: #NET-DHCP_1<CR>
NET-DHCP?	Get DHCP mode. <i>i</i> For Backward compatibility, the id parameter can be omitted. In this case, the Network ID, by default, is 0, which is the Ethernet control port.	COMMAND #NET-DHCP?_<CR> FEEDBACK ~nn@NET-DHCP_netw_id,dhcp_mode<CR><LF>	dhcp_mode – 0 – Do not use DHCP. Use the IP set by the factory or using the net-ip or net-config command. 1 – Try to use DHCP. If unavailable, use the IP set by the factory or using the net-ip or net-config command.	Get DHCP mode for port 1: #NET-DHCP?<CR>



Function	Description	Syntax	Parameters/Attributes	Example
NET-GATE	Set gateway IP. ⓘ A network gateway connects the device via another network and maybe over the Internet. Be careful of security issues. For proper settings consult your network administrator.	COMMAND #NET-GATE_ <u>ip_address</u> <CR> FEEDBACK ~nn@NET-GATE_ <u>ip_address</u> <CR><LF>	<u>ip_address</u> – Format: xxx.xxx.xxx.xxx	Set the gateway IP address to 192.168.0.1: #NET-GATE_ <u>192.168.000.001</u> <CR>
NET-GATE?	Get gateway IP. ⓘ A network gateway connects the device via another network and maybe over the Internet. Be aware of security problems.	COMMAND #NET-GATE?_ <u><CR></u> FEEDBACK ~nn@NET-GATE_ <u>ip_address</u> <CR><LF>	<u>ip_address</u> – Format: xxx.xxx.xxx.xxx	Get the gateway IP address: #NET-GATE?_ <u><CR></u>
NET-IP	Set IP address. ⓘ For proper settings consult your network administrator.	COMMAND #NET-IP_ <u>ip_address</u> <CR> FEEDBACK ~nn@NET-IP_ <u>ip_address</u> <CR><LF>	<u>ip_address</u> – Format: xxx.xxx.xxx.xxx	Set the IP address to 192.168.1.39: #NET-IP_ <u>192.168.001.039</u> <CR>
NET-IP?	Get IP address.	COMMAND #NET-IP?_ <u><CR></u> FEEDBACK ~nn@NET-IP_ <u>ip_address</u> <CR><LF>	<u>ip_address</u> – Format: xxx.xxx.xxx.xxx	Get the IP address: #NET-IP?_ <u><CR></u>
NET-MAC?	Get MAC address. ⓘ For backward compatibility, the <u>id</u> parameter can be omitted. In this case, the Network ID, by default, is 0, which is the Ethernet control port.	COMMAND #NET-MAC?<CR> FEEDBACK ~nn@NET-MAC_ <u>mac_address</u> <CR><LF>	<u>mac_address</u> – Unique MAC address. Format: XX-XX-XX-XX-XX-XX where X is hex digit	#NET-MAC?<CR>
NET-MASK	Set subnet mask. ⓘ For proper settings consult your network administrator.	COMMAND #NET-MASK_ <u>net_mask</u> <CR> FEEDBACK ~nn@NET-MASK_ <u>net_mask</u> <CR><LF>	<u>net_mask</u> – Format: xxx.xxx.xxx.xxx	Set the subnet mask to 255.255.0.0: #NET-MASK_ <u>255.255.000.000</u> <CR>
NET-MASK?	Get subnet mask.	COMMAND #NET-MASK?_ <u><CR></u> FEEDBACK ~nn@NET-MASK_ <u>net_mask</u> <CR><LF>	<u>net_mask</u> – Format: xxx.xxx.xxx.xxx	Get the subnet mask: #NET-MASK?<CR>
PASS	Set password for login level. ⓘ The default password is an empty string.	COMMAND #PASS_ <u>login_level,password</u> <CR> FEEDBACK ~nn@PASS_ <u>login_level,password</u> <CR><LF>	<u>login_level</u> – Level of login to set (End User or Admin): 0 – User 1 – Admin <u>password</u> – Password for the <u>login_level</u> . Up to 15 printable ASCII chars	Set the password for the Admin protocol permission level to 33333: #PASS_ <u>admin,33333</u> <CR>
PASS?	Get password for login level. ⓘ The default password is an empty string.	COMMAND #PASS?_ <u>login_level</u> <CR> FEEDBACK ~nn@PASS_ <u>login_level,password</u> <CR><LF>	<u>login_level</u> – Level of login to set (User or Admin): 0 – User 1 – Admin <u>password</u> – Password for the <u>login_level</u> . Up to 15 printable ASCII chars	Get the password for the Admin protocol permission level: #PASS?_ <u>admin</u> <CR>
PROG-ACTION	Set Step-In button action bitmap. ⓘ Programs matrix action as a response for external event (programmable button pressed).	COMMAND #PROG-ACTION_ <u>port_type,port_id,button_id,bitmap_actions_id</u> <CR> FEEDBACK ~nn@PROG-ACTION_ <u>port_type,port_id,button_id,bitmap_actions_id</u> <CR><LF>	<u>io_mode</u> – Input 0 – Input <u>port_id</u> – input number on the device: 1 – HDMI IN 1 2 – HDMI IN 2 3 – HDMI IN 3 4 – HDMI IN 4 5 – HDMI IN 5 6 – HDMI IN 6 7 – HDMI IN 7 8 – HDMI IN 8 <u>button_id</u> – External programmable button ID <u>bitmap_actions_id</u> – Bitmap representing actions to perform after receiving <u>button_id</u> . format: XXXX...X, where X is a hex digit. The binary form of every hex digit represents actions from the table 0 – Echo to controller 1 – Step-in out 1 2 – Step-in out 2 3 – Step-in out 3 4 – Step-in out 4 5 – Step-in out 5 6 – Step-in out 6 7 – Step-in out 7 8 – Step-in out 8 Setting '1' says that the corresponding action must be executed.	Set step-in button actions on input 3: #PROG-ACTION_ <u>0,3,1,0x07</u> <CR>

Function	Description	Syntax	Parameters/Attributes	Example
PROG-ACTION?	Get step-in button action bitmap. ① Programs matrix action as a response for external event (programmable button pressed).	COMMAND #PROG-ACTION?_port_type,port_id,button_id<CR> FEEDBACK ~nn@PROG-ACTION_port_type,port_id,button_id,bitmap_actions_id<CR><LF>	io_mode – Input 0 – Input port_id – input number on the device: 1 – HDMI IN 1 2 – HDMI IN 2 3 – HDMI IN 3 4 – HDMI IN 4 5 – HDMI IN 5 6 – HDMI IN 6 7 – HDMI IN 7 8 – HDMI IN 8 button_id – External programmable button ID bitmap_actions_id – Bitmap representing actions to perform after receiving button_id. format: XXXX...X, where X is a hex digit. The binary form of every hex digit represents actions from the table 0 – Echo to controller 1 – Step-in out 1 2 – Step-in out 2 3 – Step-in out 3 4 – Step-in out 4 5 – Step-in out 5 6 – Step-in out 6 7 – Step-in out 7 8 – Step-in out 8 Setting '1' says that the corresponding action must be executed.	Get step-in button action bitmap on input 3: #PROG-ACTION?_0,3,1<CR>
PROT-VER?	Get device protocol version.	COMMAND #PROT-VER?_<CR> FEEDBACK ~nn@PROT-VER_3000:version<CR><LF>	version – XX.XX where X is a decimal digit	Get the device protocol version: #PROT-VER?_<CR>
PRST-AUD?	LEGACY COMMAND. Get audio connections from saved preset. ① In most units, video and audio presets with the same number are stored and recalled together by commands #PRST-STO and #PRST-RCL.	COMMAND #PRST-AUD?_preset,out<CR> #PRST-AUD?_preset,*<CR> FEEDBACK ~@PRST-AUD_preset,>out<CR><LF> ~@PRST-AUD_preset,i>1,i>2,i>3,...<CR><LF>	preset – Preset number – 1 – Preset 1 2 – Preset 2 3 – Preset 3 4 – Preset 4 5 – Preset 5 6 – Preset 6 7 – Preset 7 8 – Preset 8 9 – Preset 9 10 – Preset 10 11 – Preset 11 12 – Preset 12 13 – Preset 13 14 – Preset 14 15 – Preset 15 16 – Preset 16 > – Connection character between in and out parameters out – Number that indicates the specific output: * – All outputs 1 – HDMI OUT 1 2 – HDMI OUT 2 3 – HDMI OUT 3 4 – HDMI OUT 4 5 – HDMI OUT 5 6 – HDMI OUT 6 7 – HDMI OUT 7 8 – HDMI OUT 8	Get audio connection IN 1 to OUT 3 from saved preset 1: #PRST-AUD?_1<CR>
PRST-LST?	Get saved preset list. ① In most units, video and audio presets with the same number are stored and recalled together by commands #PRST-STO and #PRST-RCL.	COMMAND #PRST-LST?_<CR> FEEDBACK ~nn@PRST-LST_preset,preset,...<CR><LF>	preset – Preset number	Show preset list: #PRST-LST?<CR>
PRST-RCL	Recall saved preset list. ① In most units, video and audio presets with the same number are stored and recalled together by commands #PRST-STO and #PRST-RCL.	COMMAND #PRST-RCL_preset<CR> FEEDBACK ~nn@PRST-RCL_preset<CR><LF>	preset – Preset number	Recall preset 1: #PRST-RCL_1<CR>

Function	Description	Syntax	Parameters/Attributes	Example
PRST-STO	<p>Store current connections, volumes and modes in preset.</p> <p>ⓘ In most units, video and audio presets with the same number are stored and recalled together by commands #PRST-STO and #PRST-RCL.</p>	<p>COMMAND</p> <pre>#PRST-STO<u>_</u>preset<CR></pre> <p>FEEDBACK</p> <pre>~nn@PRST-STO<u>_</u>preset<CR><LF></pre>	<p>preset – Preset number</p>	<p>Store preset 1:</p> <pre>#PRST-STO<u>_</u>1<CR></pre>
PRST-VID?	<p>Get video connections from saved preset.</p> <p>ⓘ In most units, video and audio presets with the same number are stored and recalled together by commands #PRST-STO and #PRST-RCL.</p>	<p>COMMAND</p> <pre>#PRST-VID?<u>_</u>preset,<u>out_id</u><CR></pre> <pre>#PRST-VID?<u>_</u>preset,*<CR></pre> <p>FEEDBACK</p> <pre>~nn@PRST-VID<u>_</u>preset,<u>in_id</u><u>out_id</u><CR><LF></pre> <pre>~nn@PRST-VID<u>_</u>preset,>1,>2,>3,...<CR><LF></pre>	<p>preset – Preset number –</p> <ul style="list-style-type: none"> 1 – Preset 1 2 – Preset 2 3 – Preset 3 4 – Preset 4 5 – Preset 5 6 – Preset 6 7 – Preset 7 8 – Preset 8 9 – Preset 9 10 – Preset 10 11 – Preset 11 12 – Preset 12 13 – Preset 13 14 – Preset 14 15 – Preset 15 16 – Preset 16 <p>in_id</p> <ul style="list-style-type: none"> 0 – disconnect output 1 – HDMI IN 1 2 – HDMI IN 2 3 – HDMI IN 3 4 – HDMI IN 4 5 – HDMI IN 5 6 – HDMI IN 6 7 – HDMI IN 7 8 – HDMI IN 8 <p>> – Connection character between in and out parameters</p> <p>out_id – Output number</p> <ul style="list-style-type: none"> * – All outputs 1 – HDMI OUT 1 2 – HDMI OUT 2 3 – HDMI OUT 3 4 – HDMI OUT 4 5 – HDMI OUT 5 6 – HDMI OUT 6 7 – HDMI OUT 7 8 – HDMI OUT 8 	<p>Get video connections from preset 3 for all outputs:</p> <pre>#PRST-VID?<u>_</u>3,*<CR></pre>
REMOTE-INFO?	<p>Get connected Step-in module information.</p> <p>ⓘ The matrix uses this command to notify about Step-in client changes.</p>	<p>COMMAND</p> <pre>#REMOTE-INFO?<u>_</u>io_mode,<u>io_index</u><CR></pre> <p>FEEDBACK</p> <pre>~nn@REMOTE-INFO<u>_</u>io_mode,<u>io_index,</u>connected_state,
model_name,<u>in_selected,</u>step-in_state,<u>in_count,</u>
cntl_btn_count,<u>in_src1,</u><u>in_src2...</u><CR><LF></pre>	<p>io_mode – Input/Output</p> <ul style="list-style-type: none"> 0 – Input 1 – Output <p>io_index – Number that indicates the specific input or output port:</p> <ul style="list-style-type: none"> 1 – HDMI IN 1 2 – HDMI IN 2 3 – HDMI IN 3 4 – HDMI IN 4 5 – HDMI IN 5 6 – HDMI IN 6 7 – HDMI IN 7 8 – HDMI IN 8 1 – HDMI OUT 1 2 – HDMI OUT 2 3 – HDMI OUT 3 4 – HDMI OUT 4 5 – HDMI OUT 5 6 – HDMI OUT 6 7 – HDMI OUT 7 8 – HDMI OUT 8 <p>connected_state – 0/1 (if module connected)</p> <p>model_name – Model name string</p> <p>in_selected – Input, currently chosen on module</p> <p>step-in_state – Step-in state</p> <ul style="list-style-type: none"> 0 – module doesn't support Step-in 1 – module supports Step-in <p>None</p> <p>in_count – 8</p> <p>cntl_btn_count – Number of control buttons on module</p> <p>in_src – Type2... typeN – Input type according to num_of_inputs</p> <ul style="list-style-type: none"> 0 – Undefined 2 – HDMI 	<p>Get connected Step-in module information:</p> <pre>#REMOTE-INFO?<u>_</u>0,1<CR></pre>

Function	Description	Syntax	Parameters/Attributes	Example
RESET	Reset device. ⓘ To avoid locking the port due to a USB bug in Windows, disconnect USB connections immediately after running this command. If the port was locked, disconnect and reconnect the cable to reopen the port.	COMMAND #RESET<CR> FEEDBACK ~nn@RESET_uk<CR><LF>		Reset the device: #RESET<CR>
SECUR	Start/stop security. ⓘ The permission system works only if security is enabled with the "SECUR" command.	COMMAND #SECUR_security_state<CR> FEEDBACK ~nn@SECUR_security_state<CR><LF>	security_state – Security state 0 – OFF (disables security) 1 – ON (enables security)	Enable the permission system: #SECUR_0<CR>
SECUR?	Get current security state. ⓘ The permission system works only if security is enabled with the "SECUR" command.	COMMAND #SECUR?_<CR> FEEDBACK ~nn@SECUR_security_state<CR><LF>	security_state – Security state 0 – OFF (disables security) 1 – ON (enables security)	Get current security state: #SECUR?_<CR>
SET-IN-CAP	Set input EDID status.	COMMAND #SET-IN-CAP_stage,stage_id,mode<CR> FEEDBACK ~nn@SET-IN-CAP_stage,stage_id,mode<CR><LF>	stage – Input: 0 – Input stage_id – Number that indicates the specific input: 0 – Color Space 1 – Color Depth 2 – Two Audio Channels mode – 0 – Pass 1 – Set	Set the input EDID support to Two Audio Channels: #SET-IN-CAP_0,2,1<CR>
SET-IN-CAP?	Get input EDID status.	COMMAND #SET-IN-CAP?_stage,stage_id<CR> FEEDBACK ~nn@SET-IN-CAP?_stage,stage_id,mode<CR><LF>	stage – Input: 0 – Input stage_id – Number that indicates the specific input: 0 – Color Space 1 – Color Depth 2 – Two Audio Channels mode – 0 – Pass 1 – Set	Get the input EDID support to Color Depth: #SET-IN-CAP?_0,1<CR>
SIGNAL?	Get input signal status.	COMMAND #SIGNAL?_in_index<CR> FEEDBACK ~nn@SIGNAL_in_index,status<CR><LF>	in_index – Number that indicates the specific input: 1 – HDMI IN 1 2 – HDMI IN 2 3 – HDMI IN 3 4 – HDMI IN 4 5 – HDMI IN 5 6 – HDMI IN 6 7 – HDMI IN 7 8 – HDMI IN 8 status – Signal status according to signal validation: 0 – Off 1 – On	Get the input signal lock status of IN 1: #SIGNAL?_1<CR>
SIG-TYPE?	Get signal type on input/output. ⓘ "Set" command is not available for all devices (refer to device specifications).	COMMAND #SIG-TYPE?_io_mode,io_index<CR> FEEDBACK ~nn@SIG-TYPE_io_mode,io_index,signal_src<CR><LF>	io_mode – Input/Output 0 – Input 1 – Output io_index – Number that indicates the specific input or output port: 1 – HDMI IN 1 2 – HDMI IN 2 3 – HDMI IN 3 4 – HDMI IN 4 5 – HDMI IN 5 6 – HDMI IN 6 7 – HDMI IN 7 8 – HDMI IN 8 1 – HDMI OUT 1 2 – HDMI OUT 2 3 – HDMI OUT 3 4 – HDMI OUT 4 5 – HDMI OUT 5 6 – HDMI OUT 6 7 – HDMI OUT 7 8 – HDMI OUT 8 signal_src – Signal type 0 – No signal 2 – HDMI	Get signal type on input/output: #SIG-TYPE?_1,1<CR>
SN?	Get device serial number.	COMMAND #SN?_<CR> FEEDBACK ~nn@SN_serial_num<CR><LF>	serial_num – 14 decimal digits, factory assigned	Get the device serial number: #SN?_<CR>

Function	Description	Syntax	Parameters/Attributes	Example
TUNNEL-CTRL	LEGACY COMMAND. Send an asynchronous command to a remote Step-in equipment.	COMMAND #TUNNEL-CTRL, <u>io_mode</u> , <u>io_index</u> , <u>cmd_name</u> <CR> FEEDBACK None	<u>io_mode</u> – Input/Output 0 – Input 1 – Output <u>io_index</u> – Number that indicates the specific input or output port: 1-N (N= the total number of input or output ports) <u>cmd_name</u> – Command to send to the Step-in client	LEGACY COMMAND: #TUNNEL-CTRL, <u>1</u> , <u>1</u> , <u>1</u> <CR>
UART	Set com port configuration. If Serial is configured when RS-485 is selected, the RS-485 UART port automatically changes. The command is backward compatible, meaning that if the extra parameters do not exist, FW goes to. RS-232. Stop_bits 1.5 is only relevant for 5 data_bits.	COMMAND #UART, <u>com_id</u> , <u>baud_rate</u> , <u>data_bits</u> , <u>parity</u> , <u>stop_bits_mode</u> , <u>serial_type</u> , <u>485_term</u> <CR> FEEDBACK ~nn@UART, <u>com_id</u> , <u>baud_rate</u> , <u>data_bits</u> , <u>parity</u> , <u>stop_bits_mode</u> , <u>serial_type</u> , <u>485_term</u> <CR><LF>	<u>com_id</u> – 1 to n (machine dependent) <u>baud_rate</u> – 9600 - 115200 <u>data_bits</u> – 5-8 <u>parity</u> – Parity Type 0 – No 1 – Odd 2 – Even 3 – Mark 4 – Space <u>stop_bits_mode</u> – 1/1.5/2 <u>serial_type</u> – 232/485 0 – 232 1 – 485 <u>485_term</u> – 485 termination state 0 – disable 1 – enable (optional - this exists only when <u>serial_type</u> is 485)	Set baud rate to 9600, 8 data bits, parity to none and stop bit to 1: #UART, <u>9600</u> , <u>8</u> , <u>none</u> , <u>1</u> <CR>
UART?	Get com port configuration. If Serial is configured when RS-485 is selected, the RS-485 UART port automatically changes. The command is backward compatible, meaning that if the extra parameters do not exist, FW goes to. RS-232. Stop_bits 1.5 is only relevant for 5 data_bits.	COMMAND #UART?, <u>com_id</u> <CR> FEEDBACK ~nn@UART, <u>com_id</u> , <u>baud_rate</u> , <u>data_bits</u> , <u>parity</u> , <u>stop_bits_mode</u> , <u>serial_type</u> , <u>485_term</u> <CR><LF>	<u>com_id</u> – 1 to n (machine dependent) <u>baud_rate</u> – 9600 - 115200 <u>data_bits</u> – 5-8 <u>parity</u> – Parity Type 0 – No 1 – Odd 2 – Even 3 – Mark 4 – Space <u>stop_bits_mode</u> – 1/1.5/2 <u>serial_type</u> – 232/485 0 – 232 1 – 485 <u>485_term</u> – 485 termination state 0 – disable 1 – enable (optional - this exists only when <u>serial_type</u> is 485)	Set baud rate to 9600, 8 data bits, parity to none and stop bit to 1: #UART, <u>1</u> , <u>9600</u> , <u>8</u> , <u>none</u> , <u>1</u> <CR>
VERSION?	Get firmware version number.	COMMAND #VERSION?,<CR> FEEDBACK ~nn@VERSION, <u>firmware_version</u> <CR><LF>	<u>firmware_version</u> – XX.XX.XXXX where the digit groups are: major.minor.build version	Get the device firmware version number: #VERSION?,<CR>
VID	LEGACY COMMAND. Set video switch state. ① The GET command identifies input switching on Step-in clients. The SET command is for remote input switching on Step-in clients (essentially via by the Web). This is a legacy command. New Step-in modules support the ROUTE command.	COMMAND #VID, <u>in_id</u> > <u>out_id</u> <CR> FEEDBACK ~nn@VID, <u>in_id</u> > <u>out_id</u> <CR><LF>	<u>in_id</u> – Indicates the ID of the input: 1-n (n= the total number of inputs) > – Connection character between in and out parameters <u>out_id</u> – Output number * for all outputs	Switch IN 1 to OUT 3: #VID, <u>1</u> > <u>3</u> <CR>
VID?	LEGACY COMMAND. Get video switch state. ① The GET command identifies input switching on Step-in clients. ② The SET command is for remote input switching on Step-in clients (essentially via by the Web). This is a legacy command. New Step-in modules support the ROUTE command.	COMMAND #VID?,<CR> FEEDBACK ~nn@VID, <u>in_id</u> > <u>out_id</u> <CR><LF>	<u>in_id</u> – Indicates the ID of the input: 1 – HDMI IN 1 2 – HDMI IN 2 3 – HDMI IN 3 4 – HDMI IN 4 5 – HDMI IN 5 6 – HDMI IN 6 7 – HDMI IN 7 8 – HDMI IN 8 > – Connection character between in and out parameters <u>out_id</u> – Output number: 1 – HDMI OUT 1 2 – HDMI OUT 2 3 – HDMI OUT 3 4 – HDMI OUT 4 5 – HDMI OUT 5 6 – HDMI OUT 6 7 – HDMI OUT 7 8 – HDMI OUT 8	Get video switch state: #VID?,<CR>

Function	Description	Syntax	Parameters/Attributes	Example
VID-PATTERN	Set test pattern on output.	COMMAND #VID-PATTERN _{out_index,pattern_id} <CR> FEEDBACK ~nn@VID-PATTERN _{out_index,pattern_id} <CR><LF>	out_index – Number that indicates the specific output: 1 – HDMI OUT 1 2 – HDMI OUT 2 3 – HDMI OUT 3 4 – HDMI OUT 4 5 – HDMI OUT 5 6 – HDMI OUT 6 7 – HDMI OUT 7 8 – HDMI OUT 8 pattern_id – Number of system patterns: 1 – Color bars 2 – Ramp 3 – Solid White 4 – Solid Black 5 – Solid Red 6 – Solid Green	Switch PATTERN 1 to OUT 3: #VID-PATTERN _{3,1} <CR>
VID-PATTERN?	Get test pattern on output.	COMMAND #VID-PATTERN? _{out_index} <CR> FEEDBACK ~nn@VID-PATTERN _{out_index,pattern_id} <CR><LF>	out_index – Number that indicates the specific output: 1 – HDMI OUT 1 2 – HDMI OUT 2 3 – HDMI OUT 3 4 – HDMI OUT 4 5 – HDMI OUT 5 6 – HDMI OUT 6 7 – HDMI OUT 7 8 – HDMI OUT 8 pattern_id – Number of system patterns: 1 – Color bars 2 – Ramp 3 – Solid White 4 – Solid Black 5 – Solid Red 6 – Solid Green	Get test pattern on output: #VID-PATTERN? ₃ <CR>
VMUTE	Set enable/disable video on output.  Video mute parameter 2 (blank picture) is not supported.	COMMAND #VMUTE _{out_index,flag} <CR> FEEDBACK ~nn@VMUTE _{out_index,flag} <CR><LF>	out_index – Number that indicates the specific output: 1 – HDMI OUT 1 2 – HDMI OUT 2 3 – HDMI OUT 3 4 – HDMI OUT 4 5 – HDMI OUT 5 6 – HDMI OUT 6 7 – HDMI OUT 7 8 – HDMI OUT 8 flag – Video Mute 0 – Video enabled 1 – Video disabled 2 – Blank picture	Disable the video output on OUT 2: #VMUTE _{2,0} <CR>
VMUTE?	Get video on output status.  Video mute parameter 2 (blank picture) is not supported.	COMMAND #VMUTE? _{out_index} <CR> FEEDBACK ~nn@VMUTE _{out_index,flag} <CR><LF>	out_index – Number that indicates the specific output: 1 – HDMI OUT 1 2 – HDMI OUT 2 3 – HDMI OUT 3 4 – HDMI OUT 4 5 – HDMI OUT 5 6 – HDMI OUT 6 7 – HDMI OUT 7 8 – HDMI OUT 8 flag – Video Mute 0 – Video enabled 1 – Video disabled 2 – Blank picture	Get video on output status: #VMUTE? ₂ <CR>
VOLUME	Set volume level.	COMMAND #VOLUME _{o_index,vol_level} <CR> FEEDBACK ~nn@VOLUME _{o_index,vol_level} <CR><LF>	o_index – Number that indicates the specific output port: 1 – Analog OUT 1 2 – Analog OUT 2 3 – Analog OUT 3 4 – Analog OUT 4 5 – Analog OUT 5 6 – Analog OUT 6 7 – Analog OUT 7 8 – Analog OUT 8 vol_level – Volume level 0 to 100%; ++ (increase current value by 2 levels); -- (decrease current value by 2 levels)	Set analog audio OUT 1 level to 50: #AUD-LVL _{1,50} <CR>
VOLUME?	Get volume level.	COMMAND #VOLUME? _{o_index} <CR> FEEDBACK ~nn@VOLUME _{o_index,vol_level} <CR><LF>	o_index – Number that indicates the specific output port: 1 – Analog OUT 1 2 – Analog OUT 2 3 – Analog OUT 3 4 – Analog OUT 4 5 – Analog OUT 5 6 – Analog OUT 6 7 – Analog OUT 7 8 – Analog OUT 8 vol_level – Volume level 0 to 100%;	Get analog OUT 8 level: #AUD-LVL? ₈ <CR>

Result and Error Codes

Syntax

In case of an error, the device responds with an error message. The error message syntax:

- **~NN@ERR XXX<CR><LF>** – when general error, no specific command
- **~NN@CMD ERR XXX<CR><LF>** – for specific command
- **NN** – machine number of device, default = 01
- **XXX** – error code

Error Codes

Error Name	Error Code	Description
P3K_NO_ERROR	0	No error
ERR_PROTOCOL_SYNTAX	1	Protocol syntax
ERR_COMMAND_NOT_AVAILABLE	2	Command not available
ERR_PARAMETER_OUT_OF_RANGE	3	Parameter out of range
ERR_UNAUTHORIZED_ACCESS	4	Unauthorized access
ERR_INTERNAL_FW_ERROR	5	Internal FW error
ERR_BUSY	6	Protocol busy
ERR_WRONG_CRC	7	Wrong CRC
ERR_TIMEDOUT	8	Timeout
ERR_RESERVED	9	(Reserved)
ERR_FW_NOT_ENOUGH_SPACE	10	Not enough space for data (firmware, FPGA...)
ERR_FS_NOT_ENOUGH_SPACE	11	Not enough space – file system
ERR_FS_FILE_NOT_EXISTS	12	File does not exist
ERR_FS_FILE_CANT_CREATED	13	File can't be created
ERR_FS_FILE_CANT_OPEN	14	File can't open
ERR_FEATURE_NOT_SUPPORTED	15	Feature is not supported
ERR_RESERVED_2	16	(Reserved)
ERR_RESERVED_3	17	(Reserved)
ERR_RESERVED_4	18	(Reserved)
ERR_RESERVED_5	19	(Reserved)
ERR_RESERVED_6	20	(Reserved)
ERR_PACKET_CRC	21	Packet CRC error
ERR_PACKET_MISSED	22	Packet number isn't expected (missing packet)
ERR_PACKET_SIZE	23	Packet size is wrong
ERR_RESERVED_7	24	(Reserved)
ERR_RESERVED_8	25	(Reserved)
ERR_RESERVED_9	26	(Reserved)
ERR_RESERVED_10	27	(Reserved)
ERR_RESERVED_11	28	(Reserved)
ERR_RESERVED_12	29	(Reserved)
ERR_EDID_CORRUPTED	30	EDID corrupted
ERR_NON_LISTED	31	Device specific errors
ERR_SAME_CRC	32	File has the same CRC – no changed
ERR_WRONG_MODE	33	Wrong operation mode
ERR_NOT_CONFIGURED	34	Device/chip was not initialized

The warranty obligations of Kramer Electronics Inc. ("Kramer Electronics") for this product are limited to the terms set forth below:

What is Covered

This limited warranty covers defects in materials and workmanship in this product.

What is Not Covered

This limited warranty does not cover any damage, deterioration or malfunction resulting from any alteration, modification, improper or unreasonable use or maintenance, misuse, abuse, accident, neglect, exposure to excess moisture, fire, improper packing and shipping (such claims must be presented to the carrier), lightning, power surges, or other acts of nature. This limited warranty does not cover any damage, deterioration or malfunction resulting from the installation or removal of this product from any installation, any unauthorized tampering with this product, any repairs attempted by anyone unauthorized by Kramer Electronics to make such repairs, or any other cause which does not relate directly to a defect in materials and/or workmanship of this product. This limited warranty does not cover cartons, equipment enclosures, cables or accessories used in conjunction with this product.

Without limiting any other exclusion herein, Kramer Electronics does not warrant that the product covered hereby, including, without limitation, the technology and/or integrated circuit(s) included in the product, will not become obsolete or that such items are or will remain compatible with any other product or technology with which the product may be used.

How Long this Coverage Lasts

The standard limited warranty for Kramer products is seven (7) years from the date of original purchase, with the following exceptions:

1. All Kramer VIA hardware products are covered by a standard three (3) year warranty for the VIA hardware and a standard three (3) year warranty for firmware and software updates; all Kramer VIA accessories, adapters, tags, and dongles are covered by a standard one (1) year warranty.
2. Kramer fiber optic cables, adapter-size fiber optic extenders, pluggable optical modules, active cables, cable retractors, ring mounted adapters, portable power chargers, Kramer speakers, and Kramer touch panels are covered by a standard one (1) year warranty. Kramer 7-inch touch panels purchased on or after April 1st, 2020 are covered by a standard two (2) year warranty.
3. All Kramer Calibre products, all Kramer Minicom digital signage products, all HighSecLabs products, all streaming, and all wireless products are covered by a standard three (3) year warranty.
4. All Sierra Video MultiViewers are covered by a standard five (5) year warranty.
5. Sierra switchers & control panels are covered by a standard seven (7) year warranty (excluding power supplies and fans that are covered for three (3) years).
6. K-Touch software is covered by a standard one (1) year warranty for software updates.
7. All Kramer passive cables are covered by a lifetime warranty.

Who is Covered

Only the original purchaser of this product is covered under this limited warranty. This limited warranty is not transferable to subsequent purchasers or owners of this product.

What Kramer Electronics Will Do

Kramer Electronics will, at its sole option, provide one of the following three remedies to whatever extent it shall deem necessary to satisfy a proper claim under this limited warranty:

1. Elect to repair or facilitate the repair of any defective parts within a reasonable period of time, free of any charge for the necessary parts and labor to complete the repair and restore this product to its proper operating condition. Kramer Electronics will also pay the shipping costs necessary to return this product once the repair is complete.
2. Replace this product with a direct replacement or with a similar product deemed by Kramer Electronics to perform substantially the same function as the original product. If a direct or similar replacement product is supplied, the original product's end warranty date remains unchanged and is transferred to the replacement product.
3. Issue a refund of the original purchase price less depreciation to be determined based on the age of the product at the time remedy is sought under this limited warranty.

What Kramer Electronics Will Not Do Under This Limited Warranty

If this product is returned to Kramer Electronics or the authorized dealer from which it was purchased or any other party authorized to repair Kramer Electronics products, this product must be insured during shipment, with the insurance and shipping charges prepaid by you. If this product is returned uninsured, you assume all risks of loss or damage during shipment. Kramer Electronics will not be responsible for any costs related to the removal or re-installation of this product from or into any installation. Kramer Electronics will not be responsible for any costs related to any setting up this product, any adjustment of user controls or any programming required for a specific installation of this product.

How to Obtain a Remedy Under This Limited Warranty

To obtain a remedy under this limited warranty, you must contact either the authorized Kramer Electronics reseller from whom you purchased this product or the Kramer Electronics office nearest you. For a list of authorized Kramer Electronics resellers and/or Kramer Electronics authorized service providers, visit our web site at www.kramerav.com or contact the Kramer Electronics office nearest you.

In order to pursue any remedy under this limited warranty, you must possess an original, dated receipt as proof of purchase from an authorized Kramer Electronics reseller. If this product is returned under this limited warranty, a return authorization number, obtained from Kramer Electronics, will be required (RMA number). You may also be directed to an authorized reseller or a person authorized by Kramer Electronics to repair the product.

If it is decided that this product should be returned directly to Kramer Electronics, this product should be properly packed, preferably in the original carton, for shipping. Cartons not bearing a return authorization number will be refused.

Limitation of Liability

THE MAXIMUM LIABILITY OF KRAMER ELECTRONICS UNDER THIS LIMITED WARRANTY SHALL NOT EXCEED THE ACTUAL PURCHASE PRICE PAID FOR THE PRODUCT. TO THE MAXIMUM EXTENT PERMITTED BY LAW, KRAMER ELECTRONICS IS NOT RESPONSIBLE FOR DIRECT, SPECIAL, INCIDENTAL OR CONSEQUENTIAL DAMAGES RESULTING FROM ANY BREACH OF WARRANTY OR CONDITION, OR UNDER ANY OTHER LEGAL THEORY. Some countries, districts or states do not allow the exclusion or limitation of relief, special, incidental, consequential or indirect damages, or the limitation of liability to specified amounts, so the above limitations or exclusions may not apply to you.

Exclusive Remedy

TO THE MAXIMUM EXTENT PERMITTED BY LAW, THIS LIMITED WARRANTY AND THE REMEDIES SET FORTH ABOVE ARE EXCLUSIVE AND IN LIEU OF ALL OTHER WARRANTIES, REMEDIES AND CONDITIONS, WHETHER ORAL OR WRITTEN, EXPRESS OR IMPLIED. TO THE MAXIMUM EXTENT PERMITTED BY LAW, KRAMER ELECTRONICS SPECIFICALLY DISCLAIMS ANY AND ALL IMPLIED WARRANTIES, INCLUDING, WITHOUT LIMITATION, WARRANTIES OF MERCHANTABILITY AND FITNESS FOR A PARTICULAR PURPOSE. IF KRAMER ELECTRONICS CANNOT LAWFULLY DISCLAIM OR EXCLUDE IMPLIED WARRANTIES UNDER APPLICABLE LAW, THEN ALL IMPLIED WARRANTIES COVERING THIS PRODUCT, INCLUDING WARRANTIES OF MERCHANTABILITY AND FITNESS FOR A PARTICULAR PURPOSE, SHALL APPLY TO THIS PRODUCT AS PROVIDED UNDER APPLICABLE LAW. IF ANY PRODUCT TO WHICH THIS LIMITED WARRANTY APPLIES IS A "CONSUMER PRODUCT" UNDER THE MAGNUSON-MOSS WARRANTY ACT (15 U.S.C.A. §2301, ET SEQ.) OR OTHER APPLICABLE LAW, THE FOREGOING DISCLAIMER OF IMPLIED WARRANTIES SHALL NOT APPLY TO YOU, AND ALL IMPLIED WARRANTIES ON THIS PRODUCT, INCLUDING WARRANTIES OF MERCHANTABILITY AND FITNESS FOR THE PARTICULAR PURPOSE, SHALL APPLY AS PROVIDED UNDER APPLICABLE LAW.

Other Conditions

This limited warranty gives you specific legal rights, and you may have other rights which vary from country to country or state to state.

This limited warranty is void if (i) the label bearing the serial number of this product has been removed or defaced, (ii) the product is not distributed by Kramer Electronics or (iii) this product is not purchased from an authorized Kramer Electronics reseller. If you are unsure whether a reseller is an authorized Kramer Electronics reseller, visit our web site at www.kramerav.com or contact a Kramer Electronics office from the list at the end of this document.

Your rights under this limited warranty are not diminished if you do not complete and return the product registration form or complete and submit the online product registration form. Kramer Electronics thanks you for purchasing a Kramer Electronics product. We hope it will give you years of satisfaction.



P/N:



2900-301168

Rev:



1



SAFETY WARNING

Disconnect the unit from the power supply before opening and servicing

For the latest information on our products and a list of Kramer distributors, visit our website where updates to this user manual may be found.

We welcome your questions, comments, and feedback.

The terms HDMI, HDMI High-Definition Multimedia Interface, and the HDMI Logo are trademarks or registered trademarks of HDMI Licensing Administrator, Inc. All brand names, product names, and trademarks are the property of their respective owners.