

NEW

Key Features

- Intel Skylake i7/i5/i3/Pentium Medical Panel PC
- 17" 1280x1024 LED Panel
- Medical 60601-1 4th edition certification
- Anti-bacteria plastic housing
- Friendly design of hot-key function
- Optional PCI-E x16 expansion slot
- Optional 4KV LAN/COM/USB isolated I/O
- Optional built-in battery pack



Outline Drawing

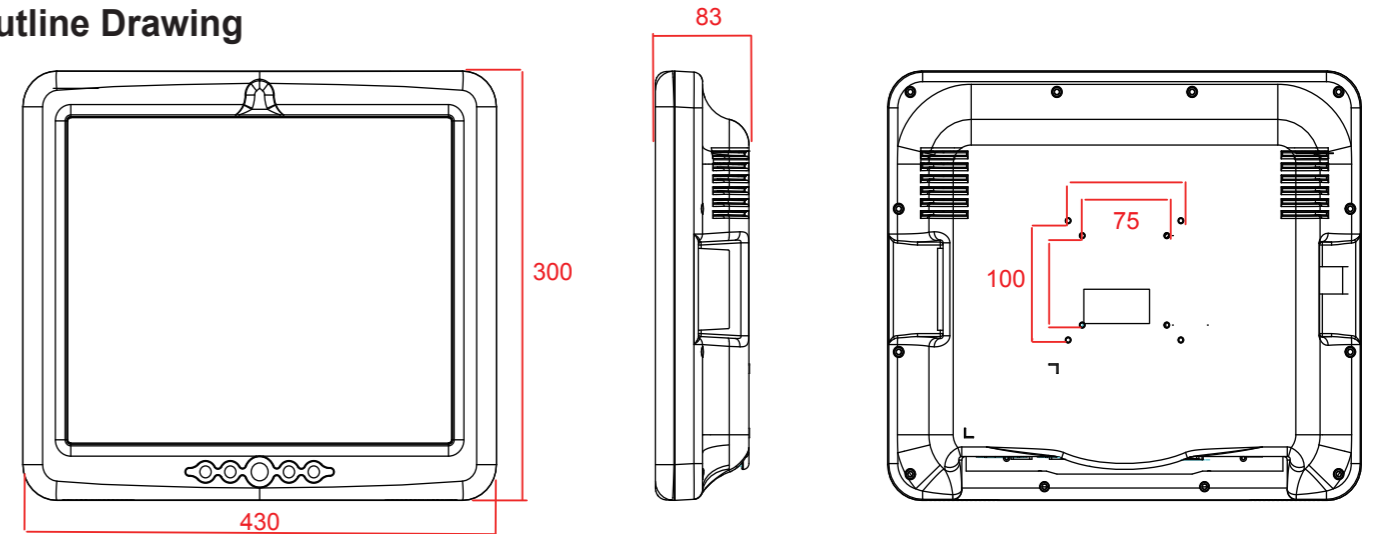

Main System

CPU	LGA1151 package 6th generation Intel® Core i7/i5/i3/Pentium processor (35W max.)
Chipset	Intel® Q170 Chipset (Intel® GL82Q170 PCH)
VGA	Intel® integrated HD Graphics 530
Memory	Two 2133 MHz DDR4 SODIMM socket support dual Channel, non-ECC, up to 32GB
Speaker	2 W x 2

LCD Panel

Size	17" 5:4
Resolution	1280 x 1024 (SXGA)
Color numbers	16.2M colors (RGB 6-bit + HiFRC data)
Viewing angle	170 (H) / 160 (V)
Contrast	1000:1 (Typ)

Touch Panel

Type	Resistive touch, 5-wire
Light transmission	81% ± 3%
Hardness	≥ 3H
Life time	35 million activations

Storage & Expansion

HDD	2.5" SATA HDD drive bay x 1
Expansion slot	<ul style="list-style-type: none"> • PCI-E x 16 expansion slot x 1 (18W max, can't co-exist with isolated module) • Card size: 100mm (W) x 220mm (D) x 14mm (H) • Mini PCIe x 2 (One half and one full support mSATA)

I/O & Power & Control Keys

USB	USB 3.0 x 4
COM	DB-9 x 2 (RS232 x 1, RS232/422/485 x 1)
LAN	RJ-45 x 2, Gigabit
Video-out	DP x 1 + DVI x 1
Audio	Line-out, Microphone-in (3.5 mm phone-jack)
Power input	DC-in x 1, DC 7~32V input (9V~28V with battery pack)
Power adaptor	AC input 90 ~ 264V / 47~63 Hz / DC output 12V, HPU 100W, medical grade, 1.2m DC cable
Power consumption	100 W (MAX. loading without adapter)
Control keys	Power, audio volume, brightness on/off,

Mechanical & Environmental

Housing	Plastic front bezel, rear cover
IP rating	IP65 – front side, IPX1 whole system
Cooling	Variable speed smart fan design, < 30 dB (typical)
Dimension	420 x 360 x 83 mm (W x H x D, w/o stand)
Weight (net)	7 Kg (approximate, w/o power adaptor)
Temperature	Operating : 0°C~40°C (chamber) Storage : -20°C~60°C
Humidity	Operating & storage – 10%~90%, non-condensing
Regulatory	<ul style="list-style-type: none"> • FCC/CE/VCCI Class B • cULus Mark/UL60601-1 • EN60601-1 approved / ISO 14971 / IEC-62133 • Energy star 6.1 compliance

Options

802.11 a/b/g/n WLAN + Bluetooth 4.0 module (Mini PCIe)
3.2M pixel webcam module (USB)
Battery pack
PCI-E x 16
Power plug holder
Power adaptor w/ 2.4m or 3.6m DC cable
Anti-bacteria desktop stand
Cable clean I/O cover, or I/O cover with Microphone
Equipotential terminal pin
TPM 1.2 module
4KV Isolated Card x 1 (Isolated COM x 2, Isolated LAN x 1, Isolated USB x 1)

Customization

USB 5,6 or COM 3,4
Tempered glass
WLAN – 802.11 a/b/g/n mini PCIe module with internal antenna x 2
PCI riser card
PoE card
Privacy Film



- | | |
|-----------------|-------------------------|
| 1 Line-out | 7 DVI-D |
| 2 Microphone-in | 8 DP x 1 |
| 3 RS232/422/485 | 9 DC-in |
| 4 RS232 | 10 Reset |
| 5 LAN x 2 | 11 PCI-E[x16] expansion |
| 6 USB 3.0 x 4 | |

Ordering Information

WMP-17F (i5)	17" FAN	i5-6500TE /4G/500G/ R-Touch
WMP-17F (i7)	17" FAN	i7-6700TE /4G/500G/ R-Touch

