

WTP-8B66-15W

15" Intel Bay Trail Stainless Wide Temp. Full IP66 Fanless Panel PC



Wide Temp.



Waterproof
Full IP66



Fanless



Stainless

Key Features

- 15" Intel Baytrail Fanless Stainless Panel PC
- Intel Quad Core E3845 Wide Temp. CPU
- IP66 full sealed with Anti-corrosion enclosure
- 15" LCD with full flat Resistive touch
- Wide Temp. -20~50 °C operation capability
- Special thermal design to meet Wide Temp.
- Special inspection of 100% waterproof guarantee
- IP67 M12 metal connectors
- IP67 power adapter and IP67 external I/O cables
- CE, FCC, VCCI Class B passed
- Optional Mini-PCIe WLAN with external antenna

Main System

CPU	Intel® Atom E3845 processor 10W
Graphics	Intel® HD Graphics
Memory	WT Dual Channel, two DDR3 SODIMM socket support up to 8GB DDR3L-1333
Serial ATA	SATA II controller (3.0Gb/sec) Port x 2
USB	USB 2.0 X 6
Serial port	RS232 x 3, RS232 / 422 / 485 x 1 (Set by BIOS, RS485 auto flow)
Audio	Realtek ALC262 Audio Codec, 2+2 watts power amplifier
LAN	Intel I210-AT Gigabit Ethernet x 2
WDT	Generates system reset; 256 segments, 0, 1, 2...255 sec/min.
BIOS	Brand: AMI Flash ROM size: 64Mb Support RTC wakeup / Wake on LAN / Power on after power failure / PnP / ACPI / RTC

LCD Panel

Size	15" 4:3
Resolution	1024x768 (XGA)
Brightness	400 nits
Contrast	600:1
Color numbers	16.7M colors (RGB 6bit + HiFRC)
Viewing angle	160 (H) / 160 (V)
Response time	8 ms (R + F)
Backlight	LED, 50,000 hours life time

Touch Panel

Type	Full Flat Resistive touch, 5-wire
Light transmittance	80±5%
Hardness	4H
Input mode	Point: Finger or touch pen Drag: Finger
Resolution	4096 x 4096
Life time	490,000 hours

Storage & Expansion

SSD	WT 128GB 2.5" SATA SSD 3MG2-P x 1
Expansion slot	Mini PCIe x 2

I/O & Control Keys

USB	1 x M12 8pin for USB 1/2 1 x M12 8pin for USB 3/4
COM	1 x M12 8pin for COM 1/RS-232 / 422 / 485 (Set by BIOS, RS485 auto flow) 1 x M12 8pin for COM 2/RS-232
LAN	1 x M12 8pin for LAN 1
Power input	1 x M12 5pin DC power connector, DC 7V~32V
Control keys	Rear bottom: Power on/off, reset

Power

Power adaptor	AC 90 ~ 264V / 47 ~ 63 Hz / DC output 12V , IP67, 60W
Power consumption	29.602 W (MAX. Loading without adapter)

Mechanical & Environmental

Housing	Stainless steel (SUS304), chassis type
IP rating	IP66 whole set (include the I/O connectors & control keys)
Cooling	Fanless
Mounting	VESA 100 x 100 mm and side mount (M6 *2)
Dimension	395 x 309.5 x 58 mm (W x H x D, not include I/O connectors)
Weight	7.6 Kg (net)
Temperature	Operating – 12V DC Input -20~50°C (IEC60068-2-56, air flow cooling) Storage – -20°C~60°C
Humidity	Operating & storage – 10%~90%, non-condensing
Regulatory	FCC, CE(EMC) , VCCI classB

WTP-8B66-15W

15" Intel Bay Trail Stainless Wide Temp. Full IP66 Fanless Panel PC

Outline Dimension

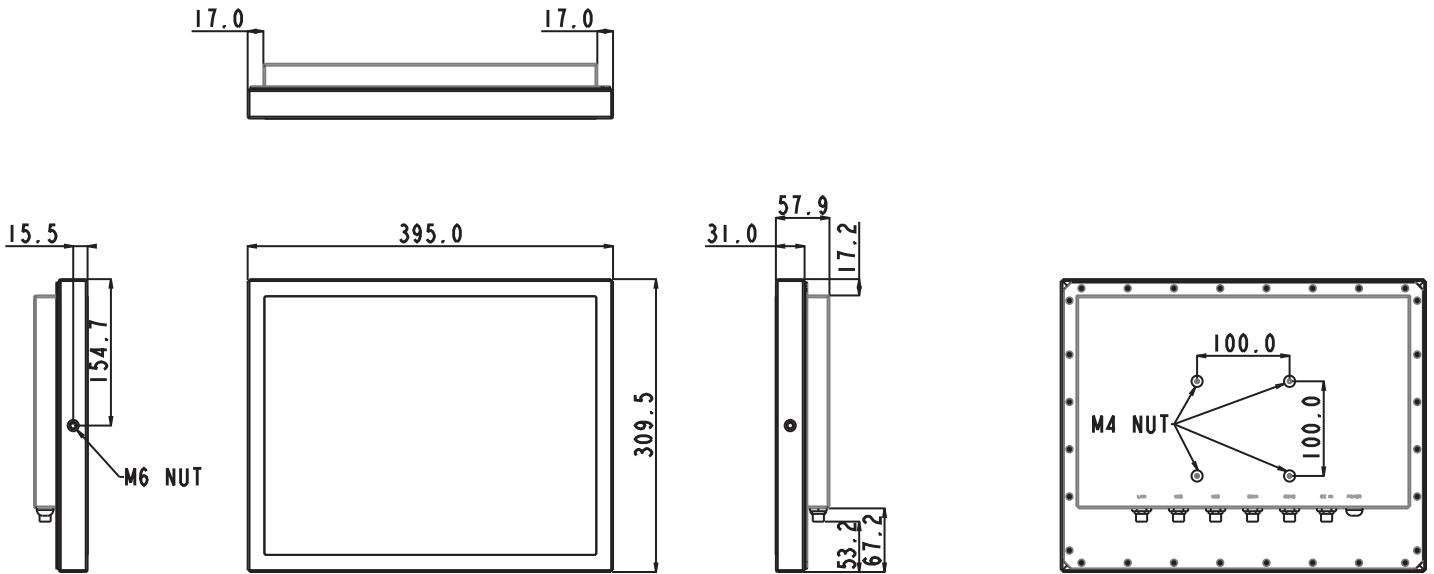

Packaging & Options

Packaging System, power adaptor, AC power cord,
DVD (drivers & manual)

Options

- Wireless or Wireless + BT kit (2 ant)
- M12 to 1x COM cable
- M12 to 1x USB cable (1 USB Port)
- M12 to 2x USB cable (2 USB Ports)
- M12 to 1x LAN cable
- (cable length is 2 meters, Waterproof)
- Wall mount / table mount bracket

Customization

- 1000 nits high brightness LCD
- Sunlight readable optical bonding
- Anti UV coating
- Full flat PCT touch screen IP69K
- LCD Auto dimming
- LCD Super dimming (Low brightness)

I/O & Control Keys

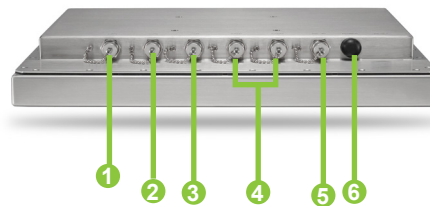

- 1 Giga Lan
- 2 USB (1/2)
- 3 USB (3/4)
- 4 COM x 2
- 5 DC-in
- 6 Power on/off



Table Mount



Wall Mount

Ordering Information

WTP-8B66-15 W

15" FANLESS

Atom E3845 CPU, Wide temp 2G RAM, wide temp 128G SSD



Wincomm Corporation

3F, NO. 14, Prosperity Road II, Science-Based Industrial Park,
Hsinchu, Taiwan 30078, R.O.C
Tel : +886 3 578 0000 Fax: +886 3 578 0295

Web: www.wincomm.com.tw

Contact: sales_support@wincomm.com.tw