

User Manual

CMS-03-S , Master IP Fan unit GUI & SNMP



Designed and manufactured by Austin Hughes



Legal Information

First English printing, November 2021

Information in this document has been carefully checked for accuracy; however, no guarantee is given to the correctness of the contents. The information in this document is subject to change without notice. We are not liable for any injury or loss that results from the use of this equipment.

Safety Instructions

Please read all of these instructions carefully before you use the device. Save this manual for future reference.

- Unplug equipment before cleaning. Don't use liquid or spray detergent; use a moist cloth.
- Keep equipment away from excessive humidity and heat. Preferably, keep it in an air-conditioned environment with temperatures not exceeding 40° Celsius (104° Fahrenheit).
- When installing, place the equipment on a sturdy, level surface to prevent it from accidentally falling and causing damage to other equipment or injury to persons nearby.
- When the equipment is in an open position, do not cover, block or in any way obstruct the gap between it and the power supply. Proper air convection is necessary to keep it from overheating.
- Arrange the equipment's power cord in such a way that others won't trip or fall over it.
- If you are using a power cord that didn't ship with the equipment, ensure that it is rated for the voltage and current labeled on the equipment's electrical ratings label. The voltage rating on the cord should be higher than the one listed on the equipment's ratings label.
- Observe all precautions and warnings attached to the equipment.
- If you don't intend on using the equipment for a long time, disconnect it from the power outlet to prevent being damaged by transient over-voltage.
- Keep all liquids away from the equipment to minimize the risk of accidental spillage. Liquid spilled on to the power supply or on other hardware may cause damage, fire or electrical shock.
- Only qualified service personnel should open the chassis. Opening it yourself could damage the equipment and invalidate its warranty.
- If any part of the equipment becomes damaged or stops functioning, have it checked by qualified service personnel.

What the warranty does not cover

- Any product, on which the serial number has been defaced, modified or removed.
- Damage, deterioration or malfunction resulting from:
 - Accident, misuse, neglect, fire, water, lightning, or other acts of nature, unauthorized product modification, or failure to follow instructions supplied with the product.
 - Repair or attempted repair by anyone not authorized by us.
 - Any damage of the product due to shipment.
 - Removal or installation of the product.
 - Causes external to the product, such as electric power fluctuation or failure.
 - Use of supplies or parts not meeting our specifications.
 - Normal wear and tear.
 - Any other causes which does not relate to a product defect.
- Removal, installation, and set-up service charges.

Regulatory Notices Federal Communications Commission (FCC)

This equipment has been tested and found to comply with the limits for a Class A digital device, pursuant to Part 15 of the FCC rules. These limits are designed to provide reasonable protection against harmful interference in business, industrial and commercial environments.

Any changes or modifications made to this equipment may void the user's authority to operate this equipment. This equipment generates, uses, and can radiate radio frequency energy and, if not installed and used in accordance with the instructions, may cause harmful interference to radio communications.

However, there is no guarantee that interference will not occur in a particular installation. If this equipment does cause harmful interference to radio or television reception, which can be determined by turning the equipment off and on, the user is encouraged to try to correct the interference by one or more of the following measures:

- Re-position or relocate the receiving antenna.
- Increase the separation between the equipment and receiver.
- Connect the equipment into an outlet on a circuit different from that to which the receiver is connected.

Unpacking

The equipment comes with the standard parts shown on the package contents. Check and make sure they are included and in good condition. If anything is missing, or damage, contact the supplier immediately.

Content

Part I. Installation P.1

< 1.1 > 1U Fan Tray

< 1.2 > 33U Door Mount Fan Panel

Part II. Hardware P.6

< 2.1 > Key Features

< 2.2 > Fan Kit Specification

< 2.3 > Master IP Fan Unit Model & Specification

MRF-1.6 (1U Fan Tray with 6 fans)

MRF-1.9 (1U Fan Tray with 9 fans)

MRF-33.9 (33U Door Mount Fan Panel with 9 fans)

Specification Table

< 2.4 > Expansion Serial Fan Unit Model & Specification

RF-1.6 (1U Fan Tray with 6 fans)

RF-1.9 (1U Fan Tray with 9 fans)

RF-33.9 (33U Door Mount Fan Panel with 9 fans)

Specification Table

< 2.5 > Daisy Chain Connection

< 2.6 > Audio Temperature Alarm Setting

< 2.7 > Temperature Sensor

< 2.8 > Alarm Temperature Setting

< 2.9 > Fan Unit CFM Setting

Part III. Software P.21

< 3.1 > **Key Features**

< 3.2 > **Master IP Configuration**

< 3.3 > **CMS-03-S Master IP Fan Unit GUI**

< 3.4 > **SNMP Setup**

< 3.5 > **Master IP Fan Unit Firmware Upgrade**

< 3.6 > **DHCP Setting**

< Part I > Installation

< 1.1 > 1U Fan Tray

Package Content

- 1U rackmount fan tray x 1 pc
- Temp. sensor x 1 pc
- 6 ft power cord x 1 pc
- Rear mounting bracket x 1 pair
- * M6 screws for fixing are not included

Installation

MRF-1.6 / RF-1.6

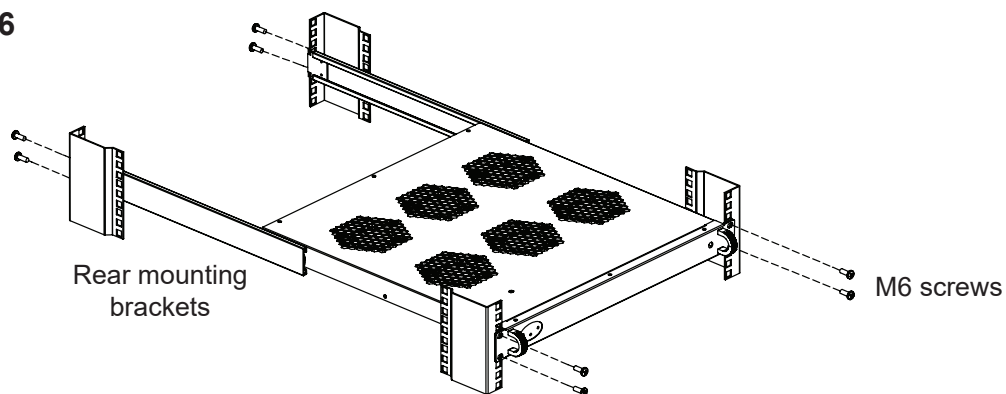

MRF-1.9 / RF-1.9

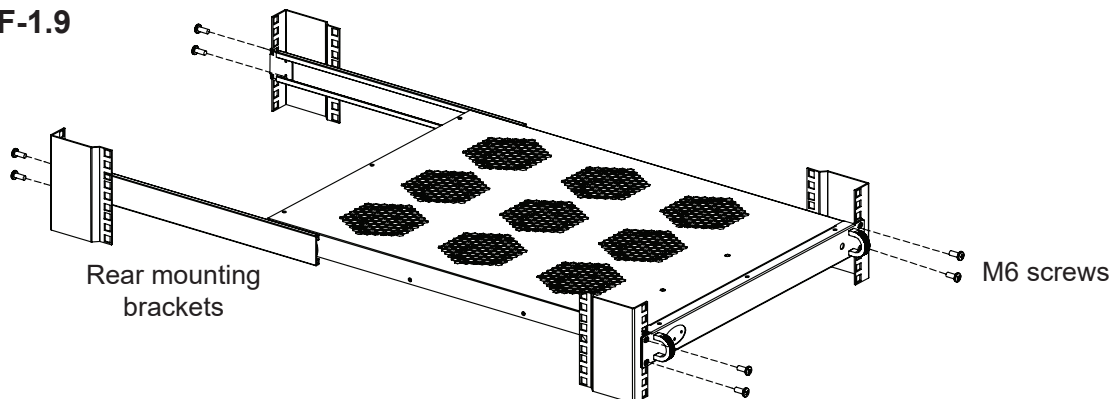

< 1.2 > 33U Door Mount Fan Panel

MRF-33.9 & RF-33.9 Door mount Fan Panel are typically installed on the outside of a rack's rear perforated door to improve extraction of heat from high density rack.

The unit can be attached to most 42U or taller racks. If aisle is relatively narrow for exterior mounting, the unit may be installed on the inside of the perforated door. For details, please refer to the model table below :

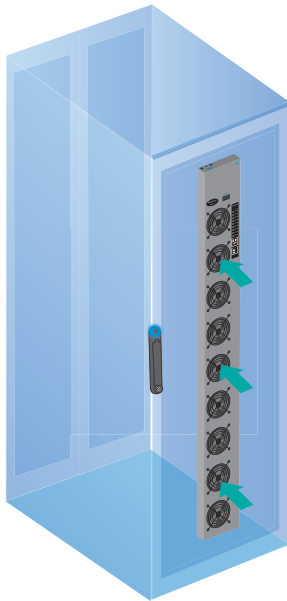

Front Door
Cool Air In

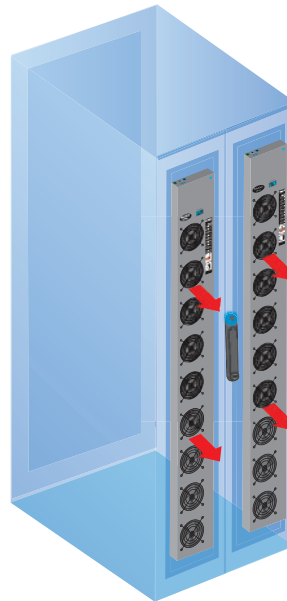

Rear Door
Hot Air Out

Model	Installation	Airflow	Purpose
MRF-33.9A RF-33.9A	Rear door outside Front door inside	Extract airflow Intake airflow	Exhaust air out from rack Cool air in from aisle
MRF-33.9B RF-33.9B	Front door outside Rear door inside	Intake airflow Extract airflow	Cool air in from aisle Exhaust air out from rack

Package Content

- 33U door mount fan panel x 1 pc
- Temp. sensor x 1 pc
- 6 ft power cord x 1 pc
- User Manual x 1 pc
- Mounting screw x 6 pcs (attached with the unit)
- Air blocking material x 1 pc

Optional mounting kit

Hanging bracket kit

- Part no. : F-HBK
- Hanging bracket x 2 pcs
 - M4*6mm screw with nut x 4 sets
 - M4*10mm screw x 2 pcs

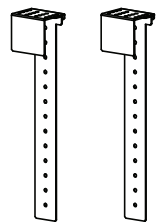

* For installation, please refer to p.5

< 1.2 > 33U Door Mount Fan Panel



Caution - Power off the fans if the door is to be opened for maintenance or service of items within the rack. The fans have finger guards but care must be exercised when working around spinning fans. Keep hair, fingers and other small objects away from the spinning blades.

Installation steps

The weight of the unit is less than 5.5 kg, so in most cases, holes in perforated rack doors can be used to mount the unit.

- 1 Lift the unit to the desired position.
- 2 Place attached 6 screws then through the door and tighten them.
- 3 Connect the power cord to the PDU of the rack through the cable entry hole on the rear of the rack.
- 4 If no cable entry on the top, the unit may be installed on the inside but the model need to be changed. Please refer to P.2 .

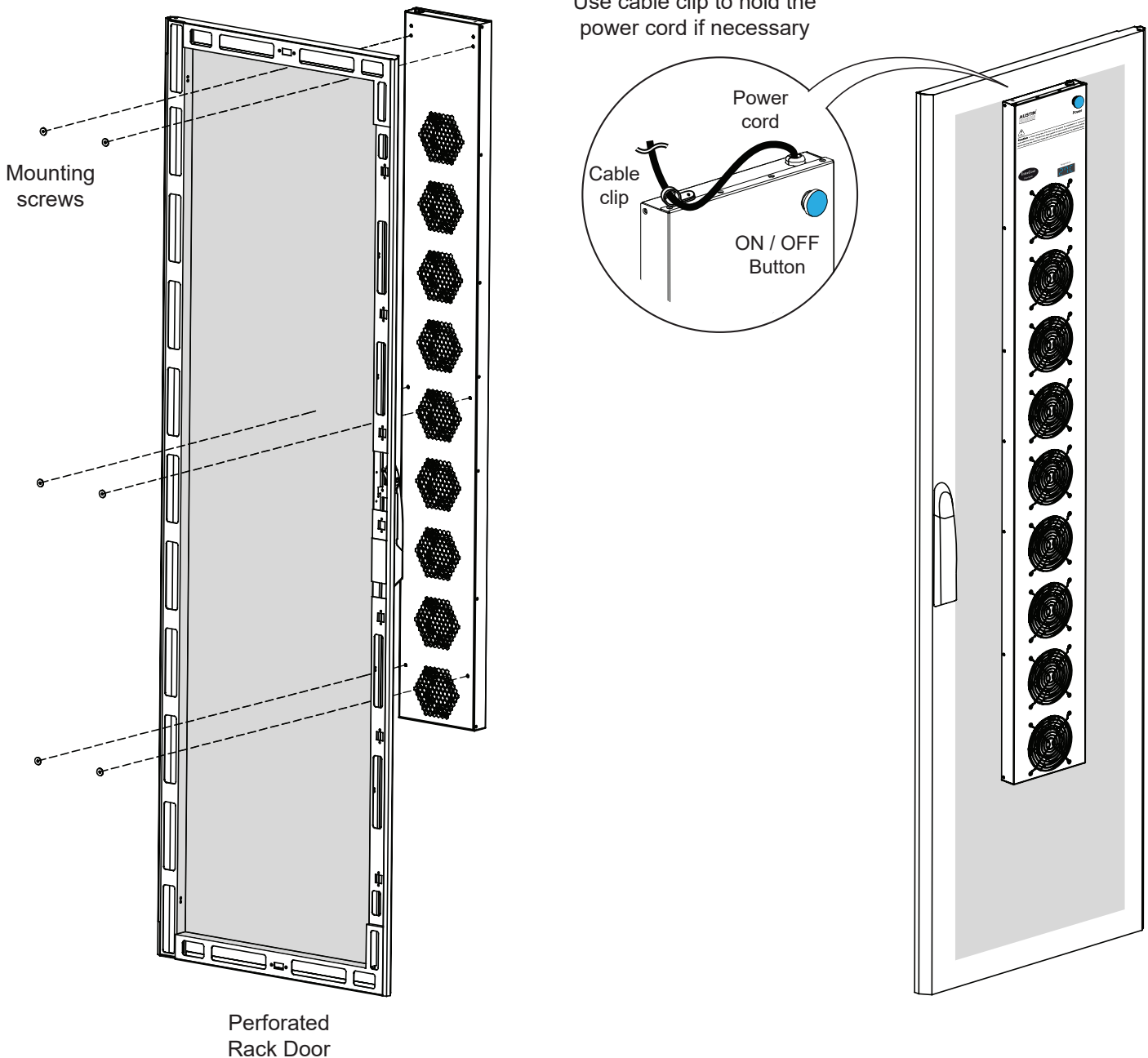

< 1.2 > 33U Door Mount Fan Panel

Air Blocking Material

To eliminate bypass air to maximize heat removal from the rack, cut the air blocking material to the size necessary with cutter or scissors, and then apply the material to the inside surface of the door with magnets or double sided adhesive tapes. Ensure all open perforations are covered by the material.

Fix the air blocking material with magnets or double sided adhesive tapes

Magnets & adhesive tapes not provided

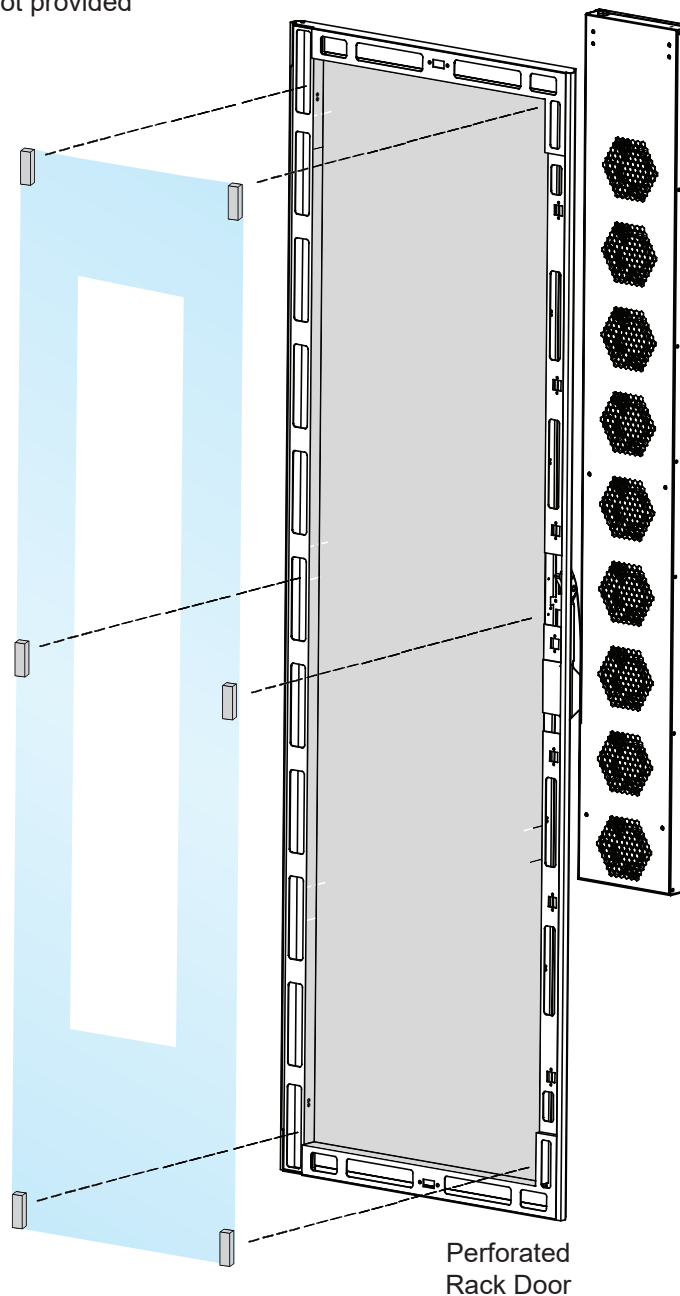

< 1.2 > 33U Door Mount Fan Panel

Hanging bracket installation

- 1 Assemble & adjust the hanging bracket with M4*6mm screw & nut, to fit the thickness of the door.
- 2 Install the hanging bracket kit on the rear side of the fan panel with M4*10mm screw.
- 3 Hang the unit on the door.
- 4 Place attached 4 screws then through the door and tighten them.
- 5 Follow steps 3 - 4 on P.3 and P.4 .

Hanging bracket with
M4*6mm screw & nut

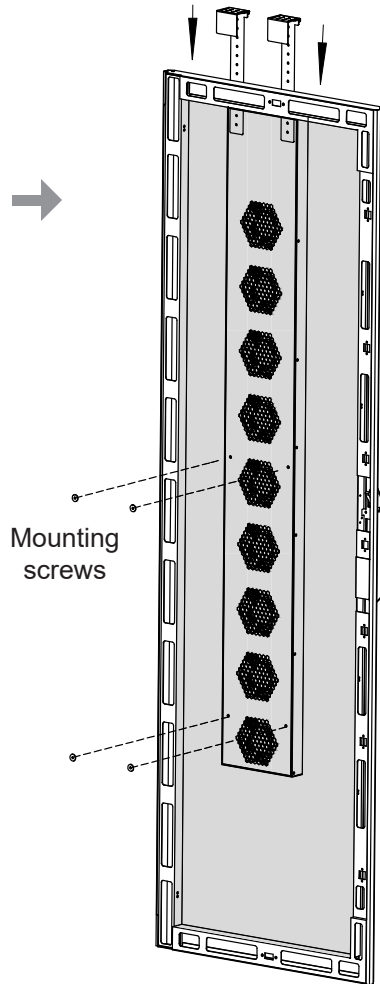
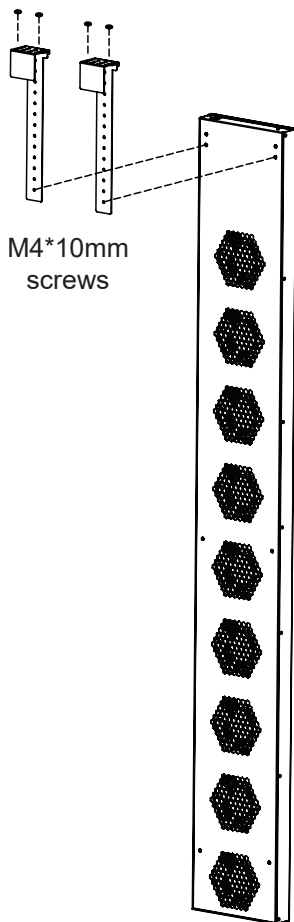

Perforated
Rack Door

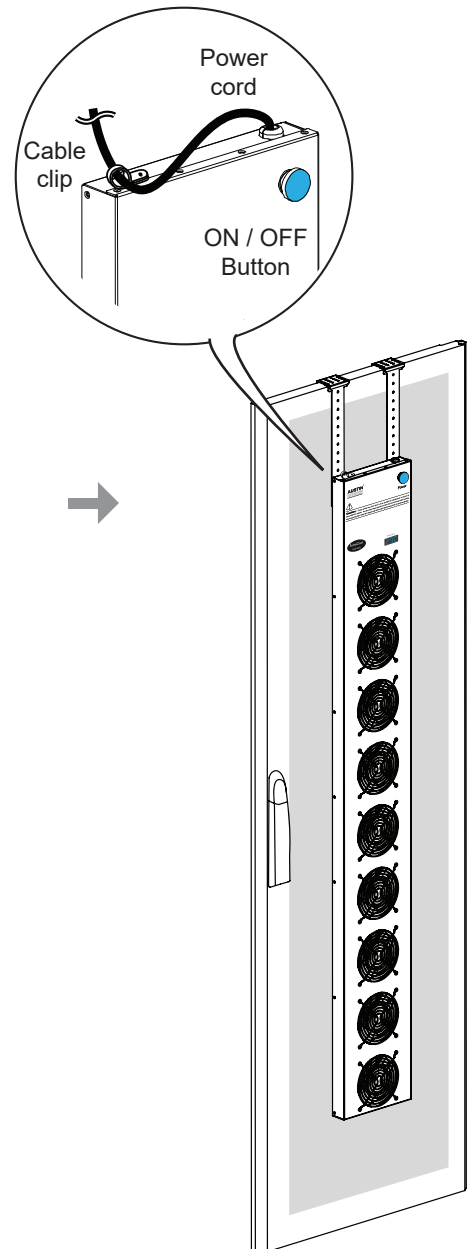

< Part II > Hardware

< 2.1 > Key Features

	Intelligent Master IP Fan Unit	Intelligent Expansion Serial Fan Unit
Daisy Chain Position	1st Level	2nd - 16th Level
IP Port	✓	
Daisy Chain Port - LINK	✓	✓
Daisy Chain Port - OUT		✓
Temp. Port	✓	✓
Temp. Sensor	✓	✓
Control Panel : - Individual Fan On / Off - Alarm Temp. Setting - Unit CFM (fan speed) Setting - Temperature LED - Fan Status LED - CFM Status LED	✓ ✓ ✓ ✓ ✓ ✓	✓ ✓ ✓ ✓ ✓ ✓
1U Fan Tray	6 / 9 fans	6 / 9 fans
Door Mount Fan Panel	9 fans	9 fans

< 2.2 > Fan Kit Specification

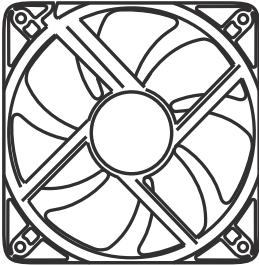

Air Delivery :	108 CFM
Rated Speed :	3000 rpm, +/-10%
Rated Voltage :	12V DC
Rated Current :	350 mA
Noise Level :	41 dB
Dimension :	120 x 120 x 25 mm
Bearing System :	Dual ball bearing

< 2.3 > Master IP Fan Unit Model



Model : MRF-1.6

1U Fan Tray with 6 fans



- 2** - Unit CFM Status LED
- Unit CFM Setting



- 1**
- Individual fan status
- Individual fan On / Off buttons

- 3**
- Buttons for Alarm
Temp. Setting
- Temp. LED display



- 4** - Temp. port bundled w/ a temp. sensor
5 - Daisy chain port for connecting to the Out port of the 2nd level fan unit
6 - 1000Base-T (Gigabit) IP port for remote access
- Enterprise level IP authentication : AD & LDAPv3 / LDAPS
- Only Master IP fan unit provides an IP port
- 1 x IP port allows access to 16 levels
7 - Press the reset button and release instantly to reboot build-in IP dongle
- Press and hold the reset button until Orange LED off to reset build-in IP dongle to factory default

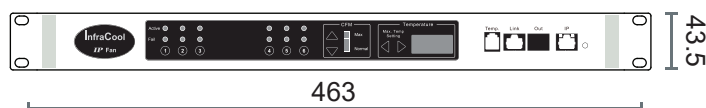
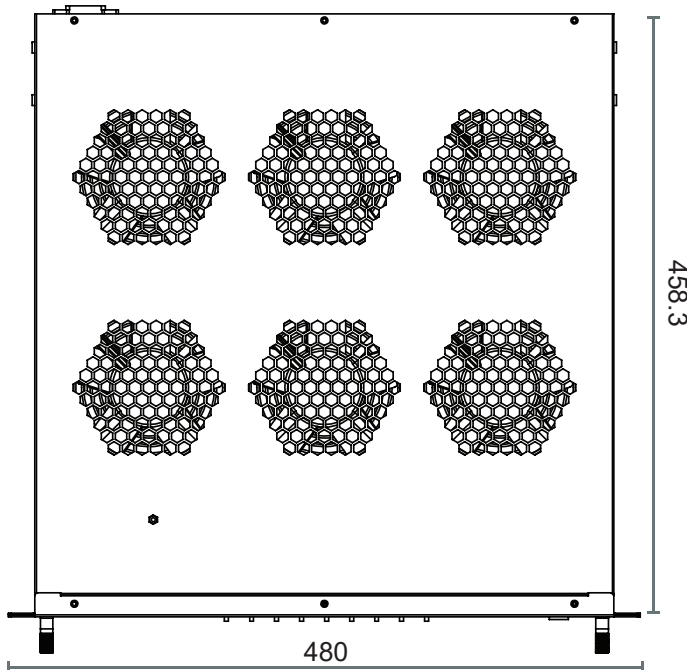

< 2.3 > Master IP Fan Unit Model



Model : MRF-1.9

1U Fan Tray with 9 fans



- 2** - Unit CFM Status LED
- Unit CFM Setting



1

- Individual fan status
- Individual fan On / Off buttons

3

- Buttons for Alarm Temp. Setting
- Temp. LED display



- 4** - Temp. port bundled w/ a temp. sensor
- 5** - Daisy chain port for connecting to the Out port of the 2nd level fan unit
- 6** - 1000Base-T (Gigabit) IP port for remote access
 - Enterprise level IP authentication : AD & LDAPv3 / LDAPS
 - Only Master IP fan unit provides an IP port
 - 1 x IP port allows access to 16 levels
- 7** - Press the reset button and release instantly to reboot build-in IP dongle
 - Press and hold the reset button until Orange LED off to reset build-in IP dongle to factory default

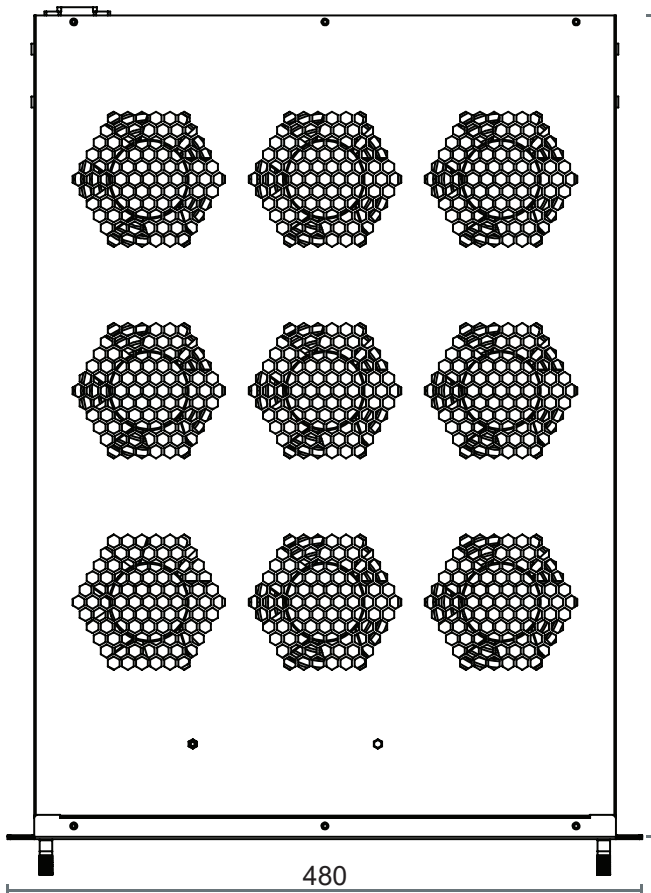

unit : mm

Model : MRF-33.9

33U Door Mount Fan Panel with 9 fans

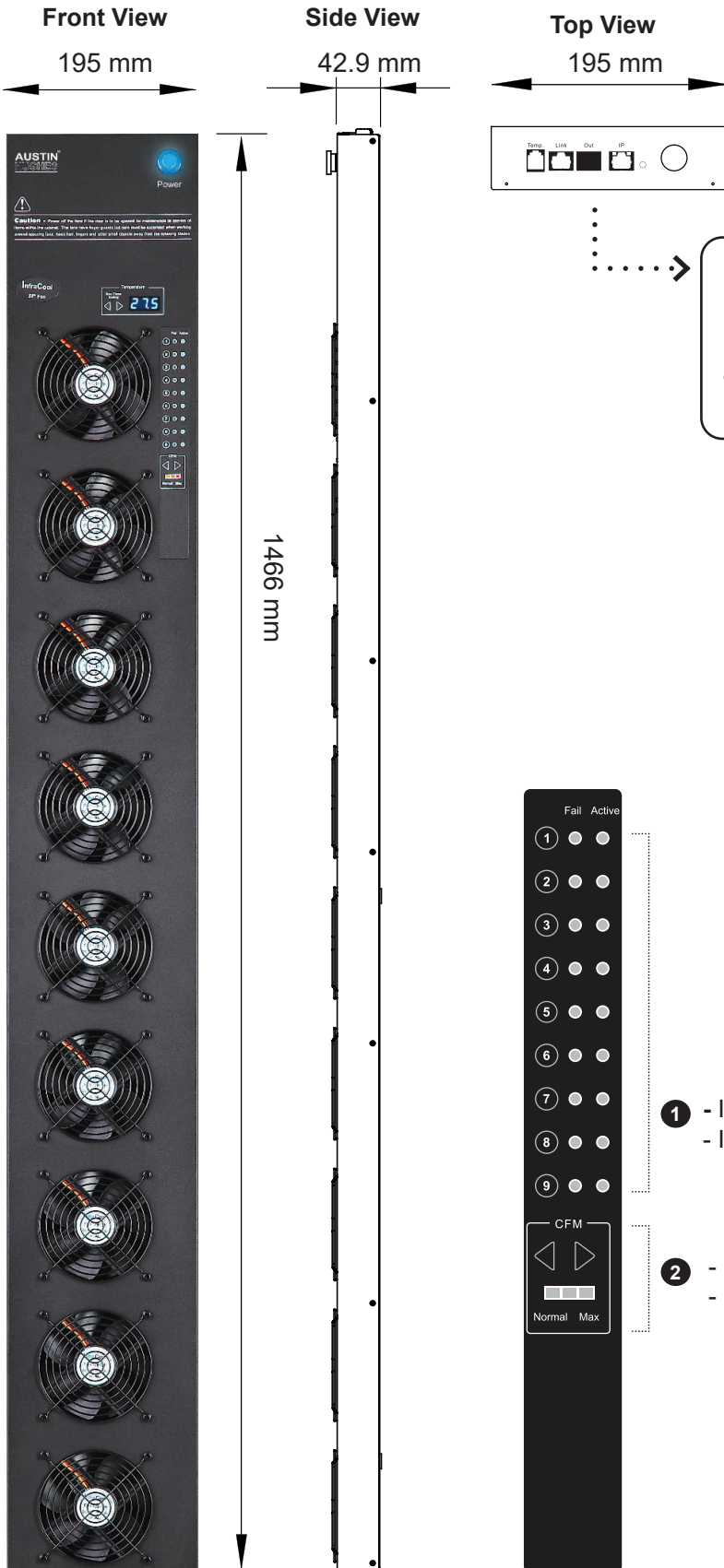

- ④ - Temp. port bundled w/ a temp. sensor
- ⑤ - Daisy chain port for connecting to the Out port of the 2nd level fan unit
- ⑥ - 1000Base-T (Gigabit) IP port for remote access
 - Enterprise level IP authentication : AD & LDAPv3 / LDAPS
 - Only Master IP fan unit provides an IP port
 - 1 x IP port allows access to 16 levels
- ⑦ - Press the reset button and release instantly to reboot build-in IP dongle
 - Press and hold the reset button until Orange LED off to reset build-in IP dongle to factory default

- ① - Individual fan status
 - Individual fan On / Off buttons
- ② - Unit CFM Status LED
 - Unit CFM (fan speed) Setting

③ - Buttons for Alarm Temp. Setting

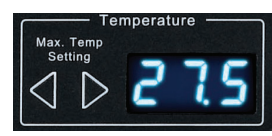

< 2.3 > Master IP Fan Unit Specification Table

Master IP Fan	Model	MRF-1.6 / 1.9	MRF-33.9
	No. of Fan	6 / 9	9
	Mounting	1U	Door mount
	CFM Level	Normal / High / Max.	
	Individual Fan ON / OFF	Yes	
	Individual Fan CFM	108 CFM	
	Unit CFM (Approximately)	324 / 648 / 972 CFM	972 CFM
	IP Remote Access	Yes	
	Daisy Chain Level	1st level, Expansion Serial fan for level 2 - 16	
	MTBF	50,000 hrs	
	Individual Fan Noise Level	41 dB	

Temperature Sensor	Temperature Port	1 x temperature sensor port (sensor bundled)
	Measurement Range	0 to 99.9°C
	Measurement Accuracy	+/- 1.5%
	Temperature Alarm	Yes

Power	Input	Auto sensing, 100V or 240V AC at 50 or 60Hz via IEC cord	
	Consumption	20W / 40W / 60W	60W

Environmental Conditions	Operating	0 to 50°C
	Storage	-5 to 60°C
	Relative Humidity	90%, non-condensing
	Shock	50G peak acceleration (11ms, half-sine wave)
	Vibration	58~100Hz / 0.98G (11ms / cycle)

Dimensions	Model	Product Dimension	Packing Dimension
	MRF-1.6	480 x 458.3 x 43.5 mm 18.9 x 18 x 1.71 inch	550 x 550 x 120 mm 21.7 x 21.7 x 4.7 inch
	MRF-1.9	480 x 623.3 x 43.5 mm 18.9 x 24.5 x 1.71 inch	550 x 730 x 120 mm 21.7 x 28.7 x 4.7 inch
	MRF-33.9	195 x 42.9 x 1466 mm 7.7 x 1.7 x 57.7 inch	263 x 106 x 1650 mm 10.4 x 4.2 x 65.0 inch

Weight	Model	Net Weight	Gross Weight
	MRF-1.6	6.8 kgs / 15 lbs	8 kgs / 17.6 lbs
	MRF-1.9	9 kgs / 19.8 lbs	11 kgs / 24.2 lbs
	MRF-33.9	5 kgs / 11 lbs	7.4 kgs / 16.3 lbs

Casing Color	Black
---------------------	-------

Regulatory	FCC & CE
-------------------	----------

Environmental	RoHS3 & REACH compliant by SGS
----------------------	--------------------------------

< 2.4 > Expansion Serial Fan Unit Model



Model : RF-1.6

1U Fan Tray with 6 fans



- 2** - Unit CFM Status LED
- Unit CFM Setting



- 1**
- Individual fan status
 - Individual fan On / Off buttons

- 3**
- Buttons for Alarm
 - Temp. Setting
 - Temp. LED display

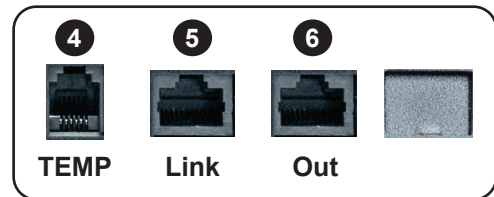

- 4** - Temp. port bundled w/ a temp. sensor
- 5** - Daisy chain Link port for connecting to the Out port of the 2nd level fan unit
- 6** - Daisy chain Out port for connecting to the Link port of the next level fan unit

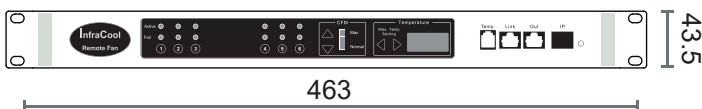
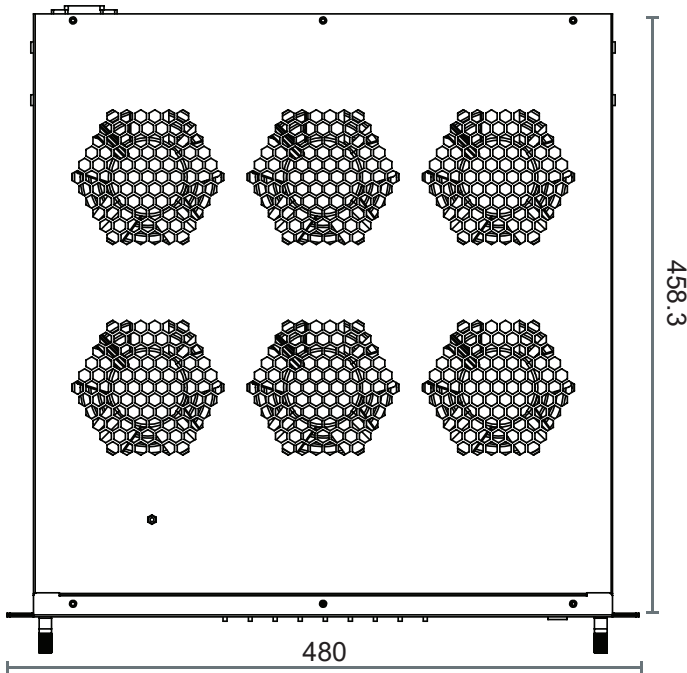

< 2.4 > Expansion Serial Fan Unit Model



Model : RF-1.9

1U Fan Tray with 9 fans



- 2** - Unit CFM Status LED
- Unit CFM Setting



- 1**
- Individual fan status
 - Individual fan On / Off buttons

- 3**
- Buttons for Alarm
 - Temp. Setting
 - Temp. LED display

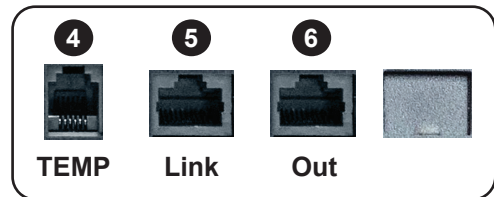

- 4** - Temp. port bundled w/ a temp. sensor
- 5** - Daisy chain Link port for connecting to the Out port of the 2nd level fan unit
- 6** - Daisy chain Out port for connecting to the Link port of the next level fan unit

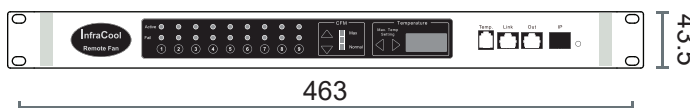
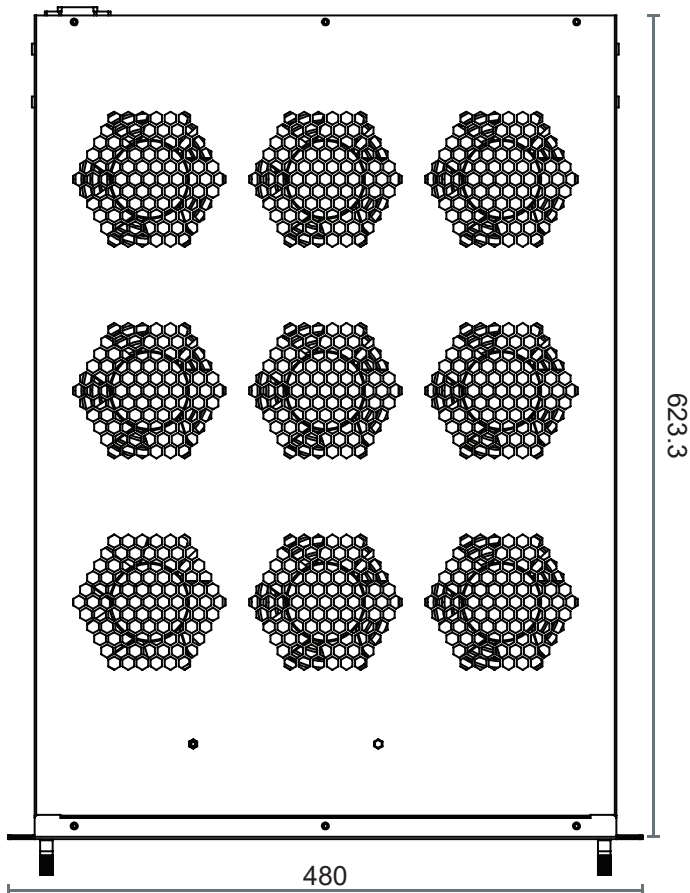

< 2.4 > Expansion Serial Fan Unit Model

Model : RF-33.9

33U Door Mount Fan Panel with 9 fans

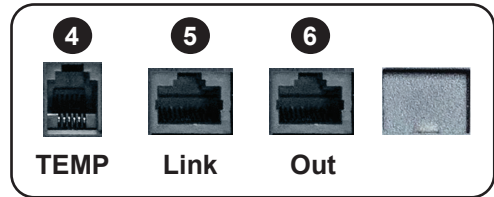
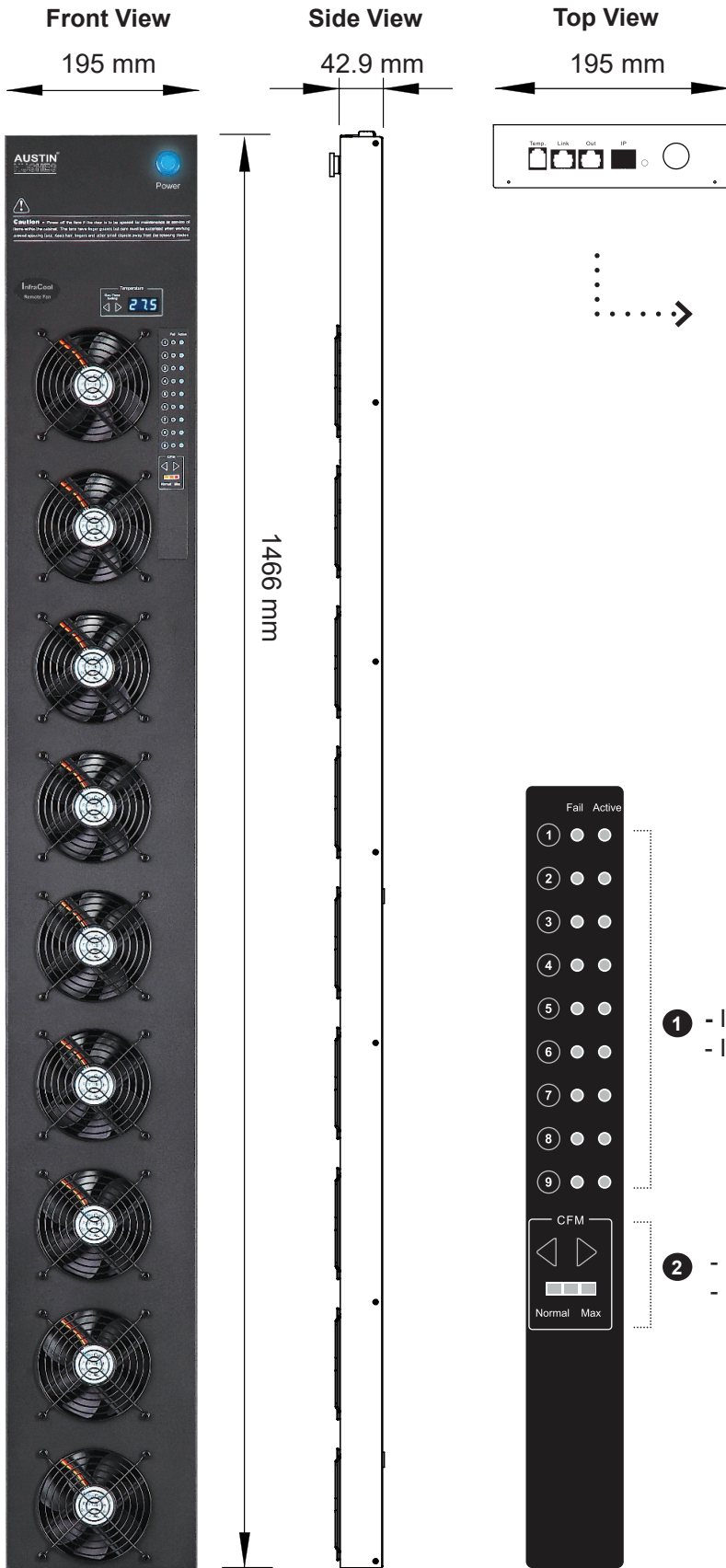

- ④ - Temp. port bundled w/ a temp. sensor
- ⑤ - Daisy chain Link port for connecting to the Out port of the 2nd level fan unit
- ⑥ - Daisy chain Out port for connecting to the Link port of the next level fan unit

- ① - Individual fan status
- Individual fan On / Off buttons

- ② - Unit CFM Status LED
- Unit CFM (fan speed) Setting

- ③ - Buttons for Alarm Temp. Setting



< 2.4 > Expansion Serial Fan Unit Specification Table

Expansion Serial Fan	Model	RF-1.6 / 1.9	RF-33.9
	No. of Fan	6 / 9	9
	Mounting	1U	Door mount
	CFM Level	Normal / High / Max.	
	Individual Fan ON / OFF	Yes	
	Individual Fan CFM	108 CFM	
	Unit CFM (Approximately)	324 / 648 / 972 CFM	972 CFM
	IP Remote Access	Not available, must be via Master IP fan on the 1st level	
	Daisy Chain Level	For Level 2 - 16	
	MTBF	50,000 hrs	
	Individual Fan Noise Level	41 dB	

Temperature Sensor	Temperature Port	1 x temperature sensor port (sensor bundled)
	Measurement Range	0 to 99.9°C
	Measurement Accuracy	+/- 1.5%
	Temperature Alarm	Yes

Power	Input	Auto sensing, 100V or 240V AC at 50 or 60Hz via IEC cord	
	Consumption	20W / 40W / 60W	60W

Environmental Conditions	Operating	0 to 50°C
	Storage	-5 to 60°C
	Relative Humidity	90%, non-condensing
	Shock	50G peak acceleration (11ms, half-sine wave)
	Vibration	58~100Hz / 0.98G (11ms / cycle)

Dimensions	Model	Product Dimension	Packing Dimension
	RF-1.6	480 x 458.3 x 43.5 mm 18.9 x 18 x 1.71 inch	550 x 550 x 120 mm 21.7 x 21.7 x 4.7 inch
	RF-1.9	480 x 623.3 x 43.5 mm 18.9 x 24.5 x 1.71 inch	550 x 730 x 120 mm 21.7 x 28.7 x 4.7 inch
	RF-33.9	195 x 42.9 x 1466 mm 7.7 x 1.7 x 57.7 inch	263 x 106 x 1650 mm 10.4 x 4.2 x 65.0 inch

Weight	Model	Net Weight	Gross Weight
	RF-1.6	6.8 kgs / 15 lbs	8 kgs / 17.6 lbs
	RF-1.9	9 kgs / 19.8 lbs	11 kgs / 24.2 lbs
	RF-33.9	5 kgs / 11 lbs	7.4 kgs / 16.3 lbs

Casing Color	Black
---------------------	-------



Regulatory	FCC & CE
-------------------	----------

Environmental	RoHS3 & REACH compliant by SGS
----------------------	--------------------------------

< 2.5 > Daisy Chain Connection

- Only Master IP Fan Unit built-in IP remote access module
- Master IP Fan unit MUST be set on the 1st daisy chain level
- Please follow the steps below the set the daisy chain level for Master IP Fan unit & expansion fan units
- For the cabling connection, please refer to next page.

Step 1. Press and hold the “” button for 5 seconds.

Step 2. Press  or  arrow button to set the daisy chain level



< 2.5 > Daisy Chain Connection

Remarks :

- Each Master IP group supports 16 daisy chain levels.
- The 1st level fan unit must be one of the Master IP fan unit models.
- 1 x Master IP fan unit allows access to 16 levels.
- For IP fan unit access, simply connect 1 x Master IP fan unit.
- The 2nd – 16th level fan unit must be one of the Expansion fan unit models.

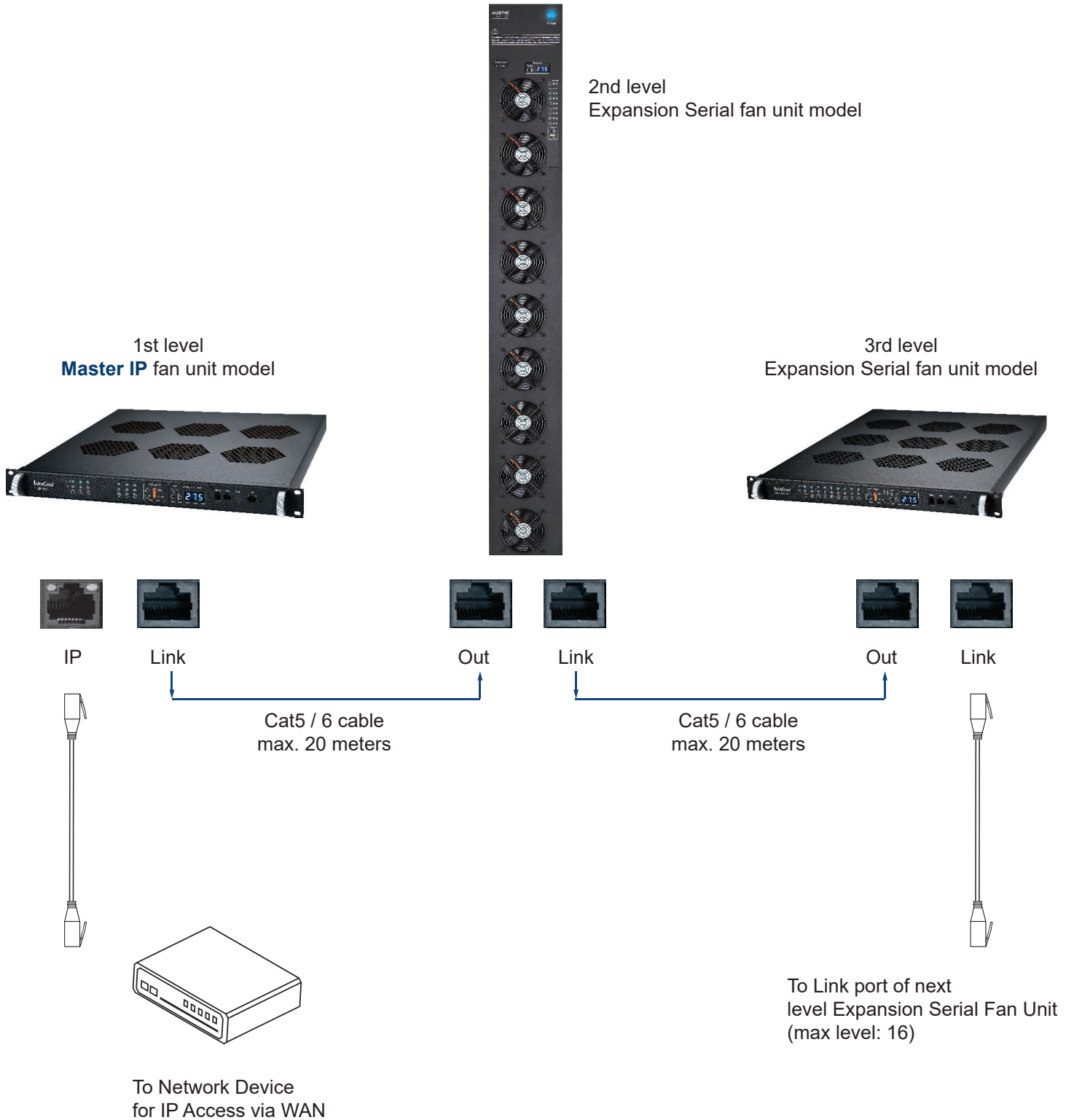

< 2.6 > Audio Temperature Alarm Setting

Please follow the steps below to setup each FAN unit audio alarm

Step 1. Press and hold the “**2**” button for 5 seconds.

Step 2. Press ◀ or ▶ arrow button to enable / disable the audio alarm

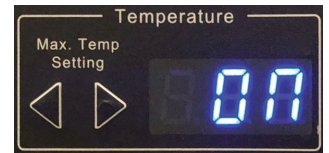

If enable the audio alarm, the buzzer will sound when the outside temperature is over the preset alarm temperature.

< 2.7 > Temperature Sensor

TEMP



Bundled Temp. Sensor

Part no. : **IG - T01 - 2M**

- Plug & Play
- External sensor with 2M cord
- Low profile design with magnetic base for easy affixing to the rack

Optional 4M cord for Temp. Sensor

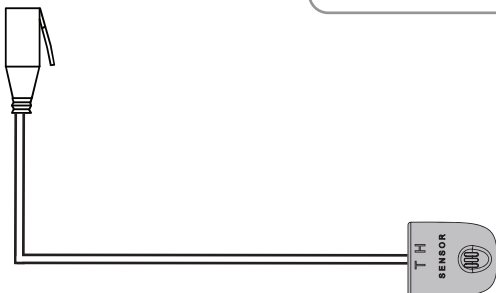

< 2.7 > Temperature Sensor



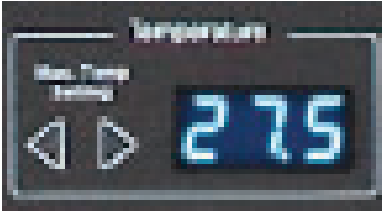

		Temp. Sensor
Part no.		IG-T01
Temperature Sensitivity	Range	0 to 80°C (32 to 176°F)
	Accuracy	±1°C (±2°F)
	Resolution	0.1°C (0.2°F)
	Response Time	5 to 30 sec
Power Requirement	Voltage	12VDC, powered by sensor port
	Current Consumption	20mA
	Power consumption	0.24 Watt
	Power on indicator	Green
Housing	Chassis & Cover	Plastic
	Color	Dark gray
	Installation	Magnetic base for unrestricted installation
Connection	Cable Length	T sensor w/ 2m cable (standard) T sensor w/ 4m cable (option)
	Cable Specification	4-wired 3.5mm to RJ11
	Cable Color	Beige
Environmental	Operating	0 to 80°C Degree
	Storage	-5 to 80°C Degree
	Humidity	0~100%, non-condensing
Dimensions	Product	30L x 25W x 18H mm
Weight	Net	66g
Supply includes	1	Temperature Sensor
	2	4-wired 3.5mm to RJ11 cable (2m, black color)
Compatibility	InfraPower	W / WS / Wi / WSi series PDU
	InfraSolution	X-2000 series
	InfraGuard	EC-300M & EC-300
Safety Regulatory		FCC & CE certified
Environmental		RoHS3 & REACH compliant

< 2.8 > Alarm Temperature Setting







How to set alarm temperature :

- Hold  for 5 seconds.
- Press   button to set the alarm temperature.

 The alarm temp. can be set either by these buttons or software.

How to set temp. unit (Celsius or Fahrenheit) :

- Hold  for 5 seconds.
- Press   button to set the temp. unit.

 The above steps are only for local LED temp. display.
Users need to set the temp. unit (°C or °F) in the software GUI separately.

< 2.9 > Fan Unit CFM Setting



To save the energy, the fan unit provides a CFM setting by three levels :

- Normal (Approx. 60% of the unit CFM)
- High (Approx. 75% of the unit CFM)
- Max. (Approx. 100% of the unit CFM)

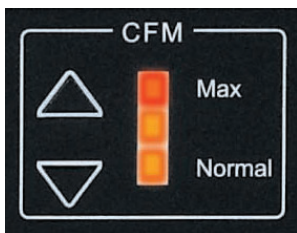
Please set the CFM according to the environmental conditions.



How to set unit CFM :

- Press   button to change the fan unit CFM setting.



However, if the outside temperature is over alarm temperature, the unit CFM will be automatically changed to Max. level. Under this condition, all fan kits will be turned on.

< 3.1 > Key Features

InfraCool Manager CMS-03-S is a FREE built-in GUI of each Master IP Fan unit to remotely monitor the connected Expansion Serial Fan units. (max. up to 16 fan units)

InfraCool Manager CMS-03-S

Features		
Capacity	Master IP group (Just 1 IP for 16 fan unit levels)	1
	Expansion Serial Fan unit number	16
	Concurrent User	1
Features	Unit CFM (fan speed) setting	✓
	Auto CFM Control Setting	✓
	Individual Fan ON / OFF	✓
	Temp. Monitoring	✓
	Alarm Temp. Setting	✓
	Graphical User Interface	✓
	Remote Access via Web Browser	✓
Fan Unit Models Support	Master IP Fan Unit (IP dongle built-in)	✓
	Expansion Serial Fan Unit	✓

< 3.2 > Master IP Configuration

Please take the following steps to configure the Master IP fan unit :

1. Prepare a notebook computer to download the IP setup utilities from the link : <http://www.austin-hughes.com/support/utilities/infracool/IPSetupUtilities.msi>
2. Double click the IPSetupUtilities.msi and follow the instruction to complete the installation.
3. Go to each Master IP fan unit with the notebook computer & a piece of CAT. 5 / 6 cable to set up the configuration by IP setup utilities as below. Please take the procedure for all Master IP fan unit **ONE BY ONE**.

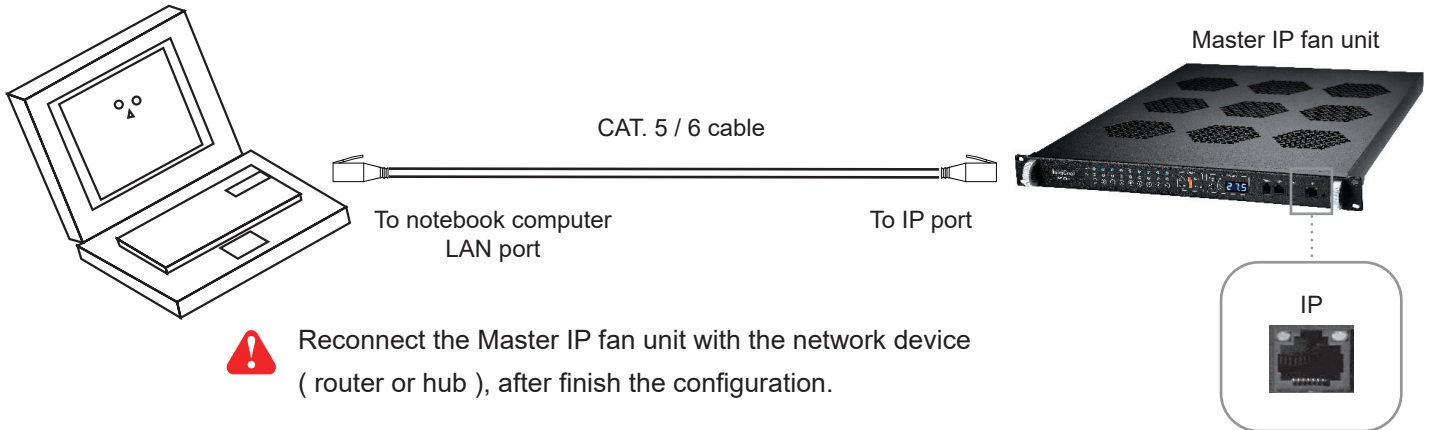

Ensure the FAN unit in power ON status

Field	Value
Device MAC address	C8:EE:08:00:57:4F
Device name	default_mrf_name
Device location	default_mrf_loc.
Password	
New password	
Confirm new password	
IP address	192.168.0.1
Subnet mask	255.255.255.0
Gateway	192.168.0.254



1. Write down the new IP address & password for login purpose, refer to < 3.3 >, < 3.4 >, < 3.5 > & < 3.6 >
2. Device name NOT EQUAL to login name of CMS-03-S WEBUI. To change login name, pls refer to P.28 < Login >.

4. Click **Scan** to search the connected Master IP fan unit.
5. Enter the device name in the “ **Device name** ” field (min. 4 char. / max. 16 char.).
The default is default_cms_name.
6. Enter the device location in the “ **Device location** ” field (min. 4 char. / max. 16 char.).
The default is default_cms_loc.
7. Enter the password in the “ **Password** ” field for authentication (min. 8 char. / max. 16 char.).
The default is 00000000.
8. Enter the new password in the “ **New password** ” field (min. 8 char. / max. 16 char.).
9. Re-enter the new password in the “ **Confirm new password** ” field.
10. Change the desired “ **IP address / Subnet mask / Gateway** ”, then click “ **Save** ” to confirm the setting to Master IP fan unit.
11. The default IP address is as below:
IP address : 192.168.0.1
Subnet mask : 255.255.255.0
Gateway : 192.168.0.254

< 3.3 > CMS-03-S Master IP Fan Unit GUI

In < **Details** > ,

- Change “ **Rack** “ and “ **Position** “ of Fan Unit and Click “ **Apply** “ to finish the settings.
- Switch ON / OFF Fan Unit
- Switch ON / OFF individual Fan
- Change Fan Unit CFM
- Click “  “ to enter “ **Temp Setting** “ page

Fan unit details

Level : MRF-1.6 1U Fan Tray
Status : Normal
Rack : Unit switch : Temp. : 23.4 °C 
Position : Unit CFM :

Fan	Status	Switch
01	Normal	<input type="button" value="OFF"/>
02	Normal	<input type="button" value="OFF"/>
03	Normal	<input type="button" value="OFF"/>
04	Normal	<input type="button" value="OFF"/>
05	Normal	<input type="button" value="OFF"/>
06	Normal	<input type="button" value="OFF"/>

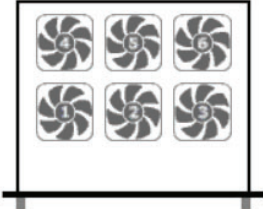

Front

* Press F11 to enlarge or diminish the screen

Auto data refresh : Untick during data input

Save new data input Return to previous page
 Discard new data input

< 3.3 > CMS-03-S Master IP Fan Unit GUI

In < Temp. Setting > ,

- “ **Activate** “ or “ **Deactivate** “ Temp. sensor
- Change “ **Location** “ , “ **Alarm Setting** “ & “ **R. alert setting** “ of Temp. sensor
- “ **Enable** “ or “ **Disable** “ auto CFM Control
- Click “ **Apply** “ to finish the above settings

-  The default Temp. setting is **Deactivate**
- When install Temp. sensor, please tick **Activate** . Otherwise, no reading display.
 - **DON'T** activate Temp. sensor if no sensor installed.

Temp. setting

Fan unit level : MRF-1.6 1U Fan Tray
Status : Normal
Rack : Rack_001
Position : 22U

Temp. sensor Activate Deactivate
Location :
Auto CFM control : Enable Disable
Alarm temp. : °C
Rising alert temp. : °C
Temp. reading : 23.4 °C

DO NOT activate temp. sensor if no sensor installed. Otherwise, temp. sensor disconnection event will be logged.
When install temp. sensor, please tick activate. Otherwise, no readings display.

When temp. alarms triggers :

1. All individual fans will change to Max. speed if auto CFM control is enabled.
2. If the temp. drops under the alarm temp. MINUS 2°C within 10 mins, the buzzer will not sound.
3. However, the buzzer will sound if the temp. **CANNOT** drop under alarm temp. MINUS 2°C within 10 mins.

Save new data input Return to previous page
 Discard new data input

< 3.3 > CMS-03-S Master IP Fan Unit GUI

In < **System** > ,

- Change Master IP Fan Unit name & location
- Change temperature unit displayed in UI
- Set the “ **Date & Time** ” of the Master IP Fan unit (by “ **Manually** ” or “ **NTP server** ”).
Default is “ **Manually** ”
- Select “ **Web Access** ” by “ **HTTP** ” or “ **HTTPS** “. Default is “ **HTTP** ”.
- Click “ **Apply** ” to finish the above settings.

Master IP Fan Unit

Name:

Location:

Temperature unit : °C °F

Date & Time: 2021-01-29 15:46:20

Time zone :

Time setting :

Date (YYYY-MM-DD) :

Time : : :

Web Access

Protocol :

Port : (Default: 443)

SSL Certificate : Use default certificate
 Use custom certificate

Operation Mode : InfraCool Manager ICM-02 Only
 WEB GUI + SNMP Only

Remarks : If you change the operation mode, the Master IP Fan Unit will reboot to make the change effective.

< 3.3 > CMS-03-S Master IP Fan Unit GUI

In < **Network** >, you can view the current IP setting of Master IP Fan unit and allows changing of these parameters.

< LAN settings >

- Enter “ **IPv4 address** “ , “ **IPv6 address** “ , “ **Subnet mask** “ , “ **Gateway** “ (For static IP setting only)
- Enter the IP address of “ **Primary DNS** “. Default is “ **8.8.8.8** “
- Enter the IP address of “ **Secondary DNS** “. Default is “ **0.0.0.0** “
- Click “ **Apply** “ to finish the above settings.

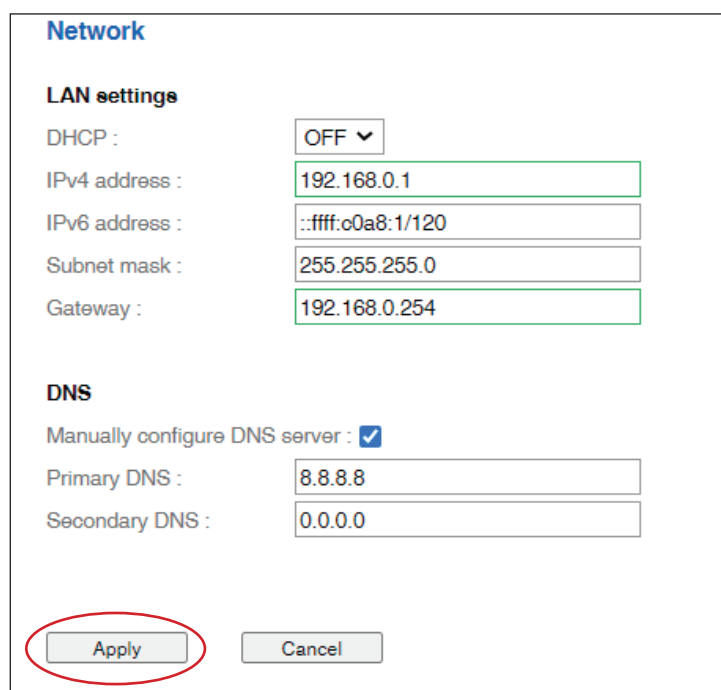

The screenshot displays the 'Network' configuration page. Under the 'LAN settings' section, there are five input fields: 'DHCP' is set to 'OFF' in a dropdown menu; 'IPv4 address' is '192.168.0.1'; 'IPv6 address' is '::ffff:c0a8:1/120'; 'Subnet mask' is '255.255.255.0'; and 'Gateway' is '192.168.0.254'. Below this, the 'DNS' section has a checked checkbox for 'Manually configure DNS server'. The 'Primary DNS' field contains '8.8.8.8' and the 'Secondary DNS' field contains '0.0.0.0'. At the bottom, the 'Apply' button is circled in red, and the 'Cancel' button is also visible.

< 3.3 > CMS-03-S Master IP Fan Unit GUI

In < **Login** >, you can login the Master IP Fan unit by “ **Local user** “ or “ **Domain/LDAP** “ login.

Default login : Local User

- Change “ **Login name** “
- Enter “ **Password** “ & “ **Confirm password** “ to confirm the change of Login name
- Click “ **Apply** “ and “ **OK** “ on the pop up window to make changes effective
- Change “ **Password** “
- Re-enter password in “ **Confirm password** ” if you change the login password
- Click “ **Apply** “ and “ **OK** “ on the pop up window to make changes effective

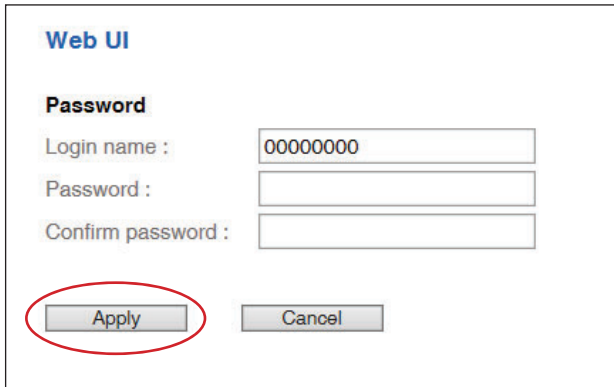

The screenshot shows a dialog box titled "Web UI" with a "Password" section. It contains three input fields: "Login name" with the value "00000000", "Password", and "Confirm password". At the bottom, there are two buttons: "Apply" and "Cancel". The "Apply" button is circled in red.

Domain/LDAP :

- Default Join Domain is “ **Disable** “
- Enable “ **Join Domain** “ only when you want to login the Master IP Fan unit by AD server
- Enter “ **AD server** “ , “ **Account Login** “ & “ **Password** “
- Click “ **Apply** “ and “ **OK** “ on the pop up window to make changes effective
- You can now go to “ **Domain User Access** “ to assign access right to the “ **Domain Users** “ or “ **Domain Group** “.

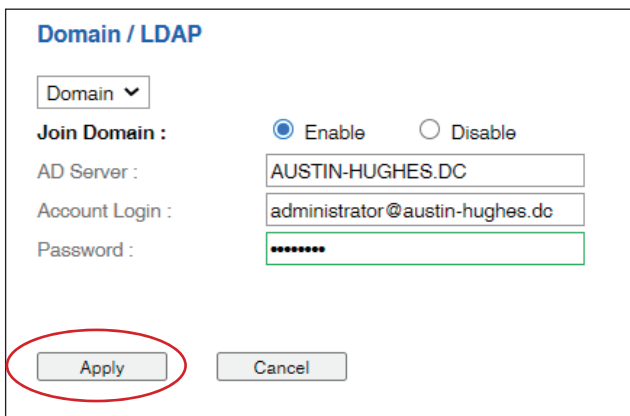

The screenshot shows a dialog box titled "Domain / LDAP". It has a "Domain" dropdown menu. Below it, the "Join Domain" section has radio buttons for "Enable" (selected) and "Disable". There are three input fields: "AD Server" with the value "AUSTIN-HUGHES.DC", "Account Login" with the value "administrator@austin-hughes.de", and "Password" with masked characters "*****". At the bottom, there are two buttons: "Apply" and "Cancel". The "Apply" button is circled in red.

< 3.3 > CMS-03-S Master IP Fan Unit GUI

- In “ **Domain User Access** “,
- Enter “ **Password** “ of administrator
- Click “ **Update user list** “ to update domain user list
- Assign access right (No access / Allow / Deny) to “ **User** “ and Click “ **Apply** “.
- The user assigned “ **Allow** “ access right can login the Master IP Fan unit WEBUI

Domain User Access

Account Login :

Password :

User

No.	User	No access	Allow	Deny
1.	Administrator	<input checked="" type="radio"/>	<input type="radio"/>	<input type="radio"/>
2.	DefaultAccount	<input checked="" type="radio"/>	<input type="radio"/>	<input type="radio"/>
3.	Guest	<input checked="" type="radio"/>	<input type="radio"/>	<input type="radio"/>
4.	Test	<input checked="" type="radio"/>	<input type="radio"/>	<input type="radio"/>
5.	chiu.chan	<input checked="" type="radio"/>	<input type="radio"/>	<input type="radio"/>
6.	databaseadmin	<input checked="" type="radio"/>	<input type="radio"/>	<input type="radio"/>
7.	ed.chan	<input checked="" type="radio"/>	<input type="radio"/>	<input type="radio"/>
8.	francois.hui	<input checked="" type="radio"/>	<input type="radio"/>	<input type="radio"/>
9.	ivan.pang	<input checked="" type="radio"/>	<input type="radio"/>	<input type="radio"/>
10.	john.choy	<input checked="" type="radio"/>	<input type="radio"/>	<input type="radio"/>
11.	kenny.wong	<input checked="" type="radio"/>	<input type="radio"/>	<input type="radio"/>
12.	kevin.li	<input checked="" type="radio"/>	<input type="radio"/>	<input type="radio"/>
13.	krbtgt	<input checked="" type="radio"/>	<input type="radio"/>	<input type="radio"/>
14.	sam.lee	<input checked="" type="radio"/>	<input type="radio"/>	<input type="radio"/>
15.	sam01	<input checked="" type="radio"/>	<input type="radio"/>	<input type="radio"/>
16.	sam02	<input checked="" type="radio"/>	<input type="radio"/>	<input type="radio"/>
17.	sam03	<input checked="" type="radio"/>	<input type="radio"/>	<input type="radio"/>
18.	test_test	<input checked="" type="radio"/>	<input type="radio"/>	<input type="radio"/>

< 3.3 > CMS-03-S Master IP Fan Unit GUI

In “ Domain Users Access “ ,

- Enter “ Password “ of administrator
- Click “ Update User list “ to update domain group list
- Assign access right (No access / Allow / Deny) to “ Group “ and Click “ Apply “ .
- The group assigned “ Allow “ access right can login the Master IP Fan unit WEBUI

Domain User Access

Account Login :

Password :

Group

No.	Group	No access	Allow
1.	Access Control Assistance Operators	<input checked="" type="radio"/>	<input type="radio"/>
2.	Account Operators	<input checked="" type="radio"/>	<input type="radio"/>
3.	Administrators	<input checked="" type="radio"/>	<input type="radio"/>
4.	Allowed RODC Password Replication Group	<input checked="" type="radio"/>	<input type="radio"/>
5.	Backup Operators	<input checked="" type="radio"/>	<input type="radio"/>
6.	Cert Publishers	<input checked="" type="radio"/>	<input type="radio"/>
7.	Certificate Service DCOM Access	<input checked="" type="radio"/>	<input type="radio"/>
8.	Cloneable Domain Controllers	<input checked="" type="radio"/>	<input type="radio"/>
9.	Cryptographic Operators	<input checked="" type="radio"/>	<input type="radio"/>
10.	DHCP Administrators	<input checked="" type="radio"/>	<input type="radio"/>
11.	DHCP Users	<input checked="" type="radio"/>	<input type="radio"/>
12.	Denied RODC Password Replication Group	<input checked="" type="radio"/>	<input type="radio"/>
13.	Department - Marketing	<input checked="" type="radio"/>	<input type="radio"/>
14.	Department - R&D	<input checked="" type="radio"/>	<input type="radio"/>
15.	Distributed COM Users	<input checked="" type="radio"/>	<input type="radio"/>
16.	DnsAdmins	<input checked="" type="radio"/>	<input type="radio"/>
17.	DnsUpdateProxy	<input checked="" type="radio"/>	<input type="radio"/>
18.	Domain Admins	<input checked="" type="radio"/>	<input type="radio"/>
19.	Domain Computers	<input checked="" type="radio"/>	<input type="radio"/>

< 3.3 > CMS-03-S Master IP Fan Unit GUI

Domain/LDAP:

Default LDAP Authentication is “ **Disable** “

Enable “ **LDAP Authentication** “ only when you want to login the Master IP Fan unit by LDAP server

Enter “ **LDAP Server** “

Select “ **Protocol** “ (LDAP / LDAPS). Default is “ **LDAP** “.

Enter “ **Port** “. Default is “ **389** “

Select “ **Encryption** “ (None / SSL). Default is “ **None** “

Enter “ **Base DN** “

Enter “ **Account Login** “ & “ **Password** “

Click “ **Apply** “ and “ **OK** “ on the pop up window to make changes effective

You can now go to “ **LDAP user access** “ to assign access right to “ **LDAP User** “ or “ **LDAP Group** “.

Domain / LDAP

LDAP ▾

LDAP Authentication : Enable Disable

LDAP Server : austin-hughes.dc

Protocol : LDAP ▾

Port : 389

Encryption : None ▾

Base DN : dc=austin-hughes,dc=dc

Account Login : administrator@austin-hughes.DC

Password :

Apply Cancel

< 3.3 > CMS-03-S Master IP Fan Unit GUI

In “ LDAP user access “

- Enter “ **Password** “ of administrator
- Click “ **Update user list** “ to update LDAP user list
- Assign access right (No access / Allow / Deny) to “ **User** “ and Click “ **Apply** “.
- The user(s) assigned “ **Allow** “ access right can login the Master IP Fan unit WEBUI

LDAP User Access

Account Login : administrator@austin-hughes.DC

Password :

Update user list

User ▾

No.	User	No access	Allow	Deny
1.	Administrator	<input type="radio"/>	<input checked="" type="radio"/>	<input type="radio"/>
2.	DefaultAccount	<input checked="" type="radio"/>	<input type="radio"/>	<input type="radio"/>
3.	Guest	<input checked="" type="radio"/>	<input type="radio"/>	<input type="radio"/>
4.	Test	<input checked="" type="radio"/>	<input type="radio"/>	<input type="radio"/>
5.	chiu.chan	<input checked="" type="radio"/>	<input type="radio"/>	<input type="radio"/>
6.	databaseadmin	<input checked="" type="radio"/>	<input type="radio"/>	<input type="radio"/>
7.	ed.chan	<input checked="" type="radio"/>	<input type="radio"/>	<input type="radio"/>
8.	francis.hui	<input checked="" type="radio"/>	<input type="radio"/>	<input type="radio"/>
9.	ivan.pang	<input checked="" type="radio"/>	<input type="radio"/>	<input type="radio"/>
10.	john.choy	<input checked="" type="radio"/>	<input type="radio"/>	<input type="radio"/>
11.	kenny.wong	<input checked="" type="radio"/>	<input type="radio"/>	<input type="radio"/>
12.	kevin.li	<input checked="" type="radio"/>	<input type="radio"/>	<input type="radio"/>
13.	krbtgt	<input checked="" type="radio"/>	<input type="radio"/>	<input type="radio"/>
14.	sam.lee	<input checked="" type="radio"/>	<input type="radio"/>	<input type="radio"/>
15.	sam01	<input checked="" type="radio"/>	<input type="radio"/>	<input type="radio"/>
16.	sam02	<input checked="" type="radio"/>	<input type="radio"/>	<input type="radio"/>
17.	sam03	<input checked="" type="radio"/>	<input type="radio"/>	<input type="radio"/>
18.	test_test	<input checked="" type="radio"/>	<input type="radio"/>	<input type="radio"/>

Apply Cancel

< 3.3 > CMS-03-S Master IP Fan Unit GUI

In “ LDAP user access “

- Enter “ **Password** “ of administrator
- Click “ **Update user list** “ to update LDAP group list
- Assign access right (No access / Allow / Deny) to “ **Group** “ and Click “ **Apply** “.
- The group(s) assigned “ **Allow** “ access right can login the Master IP Fan unit WEBUI

LDAP User Access

Account Login :

Password :

Group

No.	Group	No access	Allow
1.	Access Control Assistance Operators	<input type="radio"/>	<input type="radio"/>
2.	Account Operators	<input checked="" type="radio"/>	<input type="radio"/>
3.	Administrators	<input checked="" type="radio"/>	<input type="radio"/>
4.	Allowed RODC Password Replication Group	<input checked="" type="radio"/>	<input type="radio"/>
5.	Backup Operators	<input checked="" type="radio"/>	<input type="radio"/>
6.	Cert Publishers	<input checked="" type="radio"/>	<input type="radio"/>
7.	Certificate Service DCOM Access	<input checked="" type="radio"/>	<input type="radio"/>
8.	Cloneable Domain Controllers	<input checked="" type="radio"/>	<input type="radio"/>
9.	Cryptographic Operators	<input checked="" type="radio"/>	<input type="radio"/>
10.	DHCP Administrators	<input checked="" type="radio"/>	<input type="radio"/>
11.	DHCP Users	<input checked="" type="radio"/>	<input type="radio"/>
12.	Denied RODC Password Replication Group	<input checked="" type="radio"/>	<input type="radio"/>
13.	Department - Marketing	<input checked="" type="radio"/>	<input type="radio"/>
14.	Department - R&D	<input checked="" type="radio"/>	<input type="radio"/>
15.	Distributed COM Users	<input checked="" type="radio"/>	<input type="radio"/>
16.	DnsAdmins	<input checked="" type="radio"/>	<input type="radio"/>
17.	DnsUpdateProxy	<input checked="" type="radio"/>	<input type="radio"/>
18.	Domain Admins	<input checked="" type="radio"/>	<input type="radio"/>
19.	Domain Computers	<input checked="" type="radio"/>	<input type="radio"/>

< 3.4 > SNMP Setup

The Master IP Fan Unit can manage the connected Intelligent Expansion Fan Unit in a single daisy chain up to 16 levels via SNMP v1/v2 or v3 (Simple Network Management Protocol)

(I). Accessing MIB Files

Step 1. Click the following link to go to the mangement software download page :
<http://www.austin-hughes.com/resources/infracool/software>

Step 2. Select the appropriate MIB file of the Fan Unit series

(II). Enabling SNMP Support

i. The following steps summarize how to enable the Master IP Fan Unit for SNMP v1 / v2 support.

Step 1. Connect the Master IP Fan Unit to a computer.
(Please refer to < 3.2 > Master IP Configuration)

Step 2. Open the Internet Explorer (I.E.) version 11.0

Step 3. Enter the configured Master IP Fan Unit address into the I.E. address bar.
Default IP address is “ **192.168.0.1** “

Step 4. Enter “ **Login name** “ & “ **Password** “.
Default Login name : 00000000
Password : the one you set in Step. 7 of <3.2> Master IP Configuration

Step 5. Select the SNMP from the left navigation pane



< 3.4 > SNMP Setup

Step 6. The SNMP settings window appears as below :

SNMP

SNMP agent : Enable Disable

SNMP version : v1/v2

SNMP port : 161

sysContact : human.being<nobody@but.you>

sysLocation : Earth

sysName : PPS-03-S

SNMP configuration

Read community : public

Write community : private

Station 1 : Deactivate Activate

Trap Station IP : 192.168.0.254

Trap port : 162

Trap community : private

Station 2 : Deactivate Activate

Trap Station IP : 192.168.0.254

Trap port : 162

Trap community : private

Station 3 : Deactivate Activate

Trap Station IP : 192.168.0.254

Trap port : 162

Trap community : private

Apply Cancel

Step 7. Click “ **Enable** “ in “ **SNMP agent** “ to start the SNMP agent service

Step 8. Select “ **v1/v2** “ in “ **SNMP version** “

Step 9. Input “ **SNMP port** “. Default is 161.

Step 10. Input “ **sysContact** “. Default is human.being<nobody@but.you>

Step 11. Input “ **sysLocation** “. Default is Earth.

Step 12. Input “ **sysName** “. Default is CMS-03-S.

Step 13. Input “ **Read Community** “. Default is “ public “

Step 14. Input “ **Write Community** “. Default is “ private “

Step 15. Click “ **Activate** “ in Station 1 to enable the trap service

Step 16. Input “ **Trap Station IP** “ , “ **Trap Port** “ & “ **Trap Community** “ of Station 1

Step 17. Repeat Step 15 & 16 for Station 2 & 3.

Step 18. Click “ **Apply** “ to finish the SNMP v1 / v2 settings

< 3.4 > SNMP Setup

ii. The following steps summarize how to enable the Master IP Fan Unit for SNMP v3 support.

Step 1. Connect the Master IP Fan Unit to a computer.
(Please refer to < 3.2 > Master IP Configuration)

Step 2. Open Internet Explorer (I.E.) version 11.0

Step 3. Enter the configured Master IP Fan Unit address into the I.E. address bar
Default IP address is “ 192.168.0.1 “

Step 4. Enter “ **Login name** “ & “ **Password** “ .
Default Login name : 00000000
Password : the one you set in Step. 7 of <3.2> Master IP Configuration

Step 5. Select SNMP from the left navigation pane

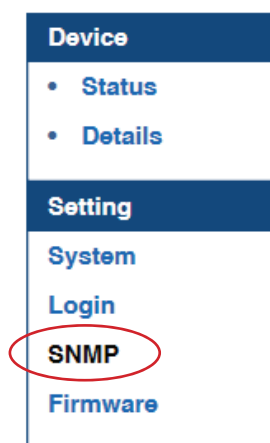

Step 6. The **SNMP** Settings window appears as below:

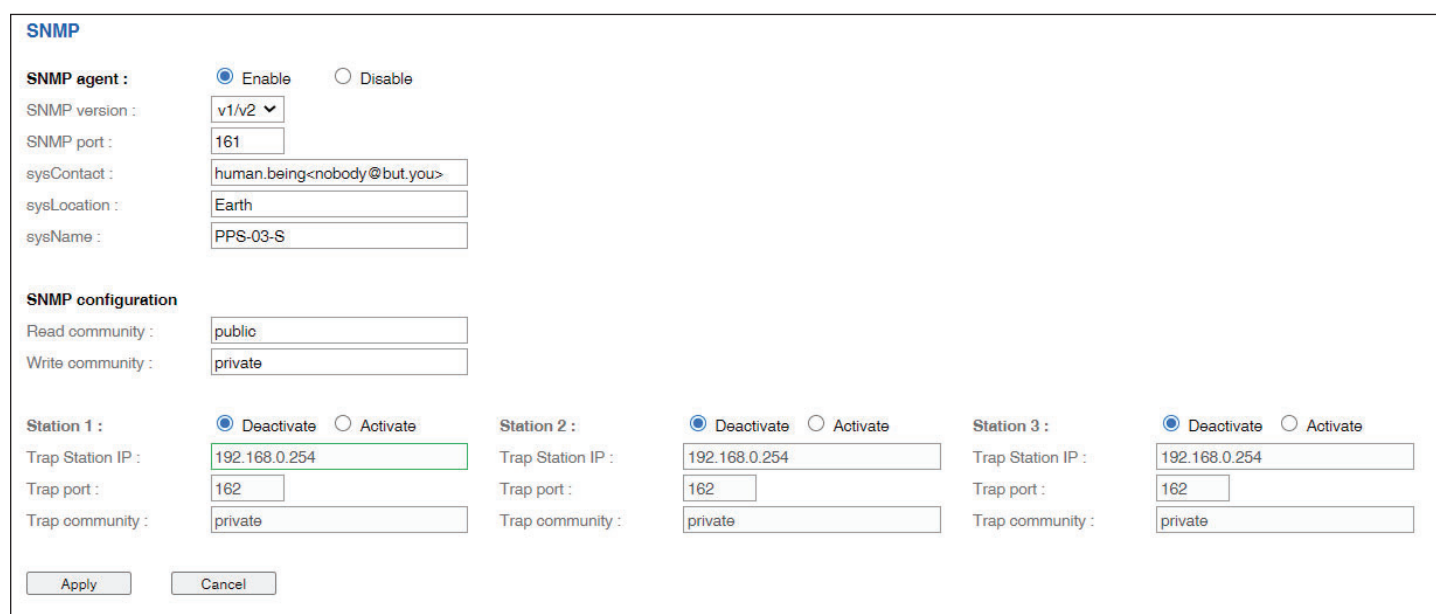
A screenshot of the 'SNMP' settings window. The window is titled 'SNMP' and contains several sections. The 'SNMP agent' section has radio buttons for 'Enable' (selected) and 'Disable'. Below it are fields for 'SNMP version' (v1/v2), 'SNMP port' (161), 'sysContact' (human.being<nobody@but.you>), 'sysLocation' (Earth), and 'sysName' (PPS-03-S). The 'SNMP configuration' section has fields for 'Read community' (public) and 'Write community' (private). The 'Station 1', 'Station 2', and 'Station 3' sections each have radio buttons for 'Deactivate' (selected) and 'Activate'. Below each station name are fields for 'Trap Station IP' (192.168.0.254), 'Trap port' (162), and 'Trap community' (private). At the bottom of the window are 'Apply' and 'Cancel' buttons.

< 3.4 > SNMP Setup

Step 7. Click “ **Enable** “ in “ **SNMP agent** “ to start the SNMP agent service

Step 8. Select “ **v3** “ in “ **SNMP version** “ & the SNMP v3 settings window appears as below :

The screenshot shows the SNMP v3 configuration window. The 'SNMP agent' is enabled. The 'SNMP version' is set to 'v3'. The 'SNMP port' is '161'. The 'sysContact' is 'human.being<nobody@but.you>', 'sysLocation' is 'Earth', and 'sysName' is 'PPS-03-S'. The 'SNMP configuration' section has three users: User 1, User 2, and User 3. Each user has 'Deactivate' selected. User 1 has 'read only' role, 'usm_user1' user, and 'None' for auth and privacy algorithms. User 2 has 'read only' role, 'usm_user2' user, and 'None' for auth and privacy algorithms. User 3 has 'read only' role, 'usm_user3' user, and 'None' for auth and privacy algorithms. Each user has a password field with asterisks. The 'SNMP trap' section has 'Disabled' selected for all three users. The 'Trap Station IP' is '192.168.0.254' and 'Trap port' is '162'. The 'Apply' button is circled in red.

Step 9. Input “ **SNMP port** “. Default is 161.

Step 10. Input “ **sysContact** “. Default is human.being<nobody@but.you>

Step 11. Input “ **sysLocation** “. Default is Earth.

Step 12. Input “ **sysName** “. Default is CMS-03-S.

Step 13. Click “ **Activate** “ in User 1.

Step 14. Select “ **Read Only** “ or “ **Read & Write** “ in User role :

Step 15. Input the name of “ **USM user** “. Default is usm_user1

Step 16. Select “ **None / MD5 / SHA** “ in “ **Auth algorithm** “.
If you select “ **Read & Write** “ in “ **User role:** “ ,
you **MUST** select “ **MD5 / SHA** “ in “ **Auth algorithm** “

Step 17. Input the “ **Auth password:** “ Default is “ 00000000 “

Step 18. Select “ **None / DES / AES** “ in “ **Privacy algorithm** “.
If the Auth algorithm is “ **NONE** “ , NO privacy algorithm can be selected.

Step 19. Input the “ **Privacy password** “

Step 20. If you want to receive trap message, select “ **Enable** “ in **SNMP trap**

Step 21. Input the “ **Trap Station IP** “ & “ **Trap port** “

Step 22. Repeat step 13 to 21 for User 2 & 3.

Step 23. Click “ **Apply** “ to finish the SNMP v3 settings.

< 3.5 > Master IP Fan Unit Firmware Upgrade

< Firmware Upgrade >

For Function enhancement or Bug fix of Master IP Fan Unit WEBUI :

Step 1. Click the following link to go to the Management software download page :
<http://www.austin-hughes.com/resources/infracool/software>

Step 2. Select the appropriate Master IP Fan Unit firmware file of the Fan Unit series

Step 3. Connect the Master IP Fan Unit to the computer.
(Please refer to < 3.2 > Master IP Configuration)

Step 4. Open the Internet Explorer (I.E.) version 11.0

Step 5. Enter the configured Master IP Fan Unit address into the I.E. address bar.
Default IP address is “ 192.168.0.1 “

Step 6. Enter “ **Login name** “ & “ **Password** “ .
Default Login name : 00000000
Password : the one you set in Step. 7 of <3.2> Master IP Configuration

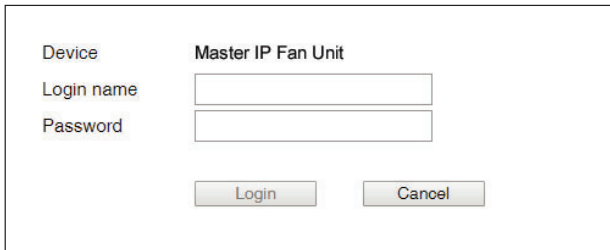

Device	Master IP Fan Unit
Login name	<input type="text"/>
Password	<input type="password"/>
<input type="button" value="Login"/> <input type="button" value="Cancel"/>	

Step 7. Select the Firmware from the left navigation pane

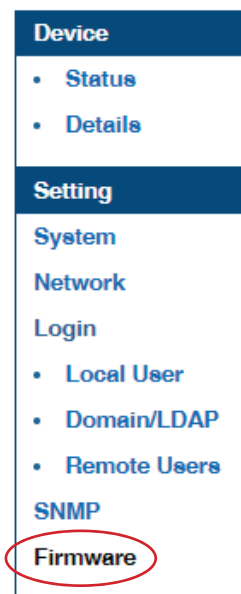

< 3.5 > Master IP Fan Unit Firmware Upgrade

Step 8. The firmware upgrade window appears as below :

Firmware

Device information

Device : Master IP Fan Unit
Firmware version: MRF-F100-210128
Hardware revision: 2.0

LAN information

IPv4 address : 192.168.1.41
IPv6 address : ::ffff:c0a8:1/120
MAC address : 20:0A:0D:FF:EE:F5

Upgrade firmware

File path :

Warning : Upgrading firmware may take a few minutes,
please don't turn off the power or press the reset button.

Step 9. Click “ **Browse** ” and select the firmware file (xxx.enc) from the specific path in the pop up window and Click “ **Open** ”

Step 10. Click “ **Upgrade** ” to start the upgrade process. It takes a few minutes to complete.
Do NOT close the Browser during the upgrade process.

Step 11. Once complete, UI will return to the login page.

< 3.6 > DHCP Setting

Step 1. Connect the Master IP Fan Unit to the computer
(Please refer to < 3.2 > Master IP Configuration)

Step 2. Open the Internet Explorer (I.E.) version 11.0

Step 3. Enter the configured Master IP Fan Unit address into the I.E address bar.

Default IP address is is “ 192.168.0.1 “

Step 4. Enter the “ **Login name** “ & “ **Password** “ .

Default Login name : 00000000

Password : the one you set in Step. 7 of <3.2> Master IP Configuration

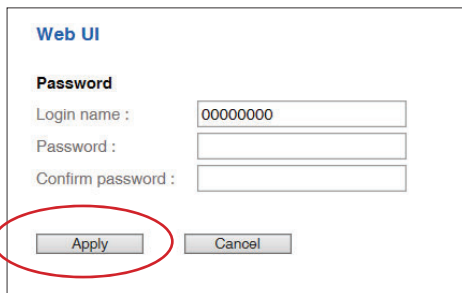

Web UI

Password

Login name : 00000000

Password :

Confirm password :

Apply Cancel

Step 5. Select “ **Network** “ from the left navigation pane

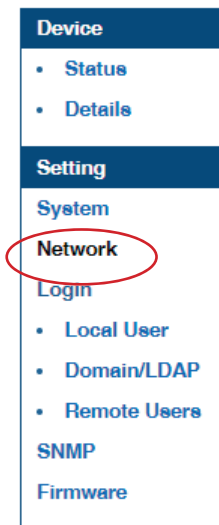

< 3.6 > DHCP Setting

Step 6. Select "ON" from "DHCP" & click "Apply" to save the settings

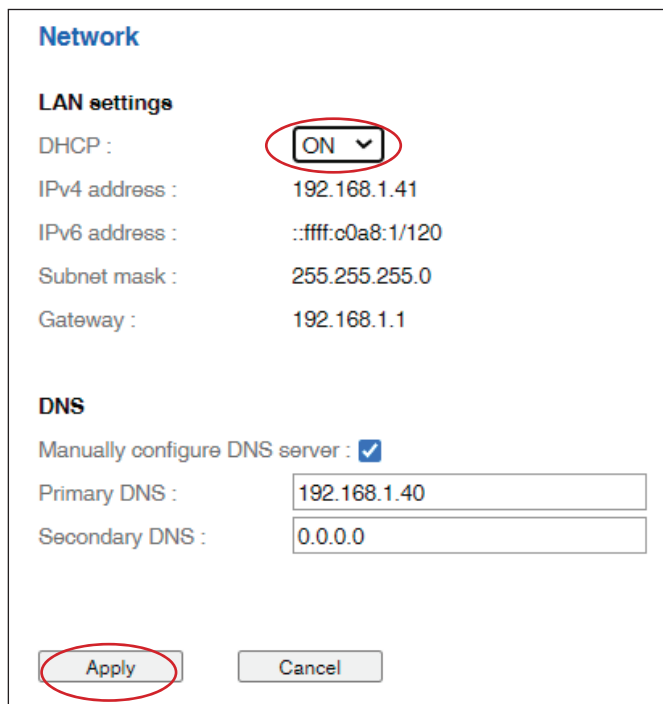

The screenshot shows a configuration window titled "Network". Under the "LAN settings" section, the "DHCP" option is set to "ON" and is circled in red. Other settings include IPv4 address (192.168.1.41), IPv6 address (::ffff:c0a8:1/120), Subnet mask (255.255.255.0), and Gateway (192.168.1.1). The "DNS" section has "Manually configure DNS server" checked. The "Primary DNS" is 192.168.1.40 and the "Secondary DNS" is 0.0.0.0. At the bottom, the "Apply" button is circled in red, along with a "Cancel" button.

Step 7. Select "Firmware" from the left navigation pane

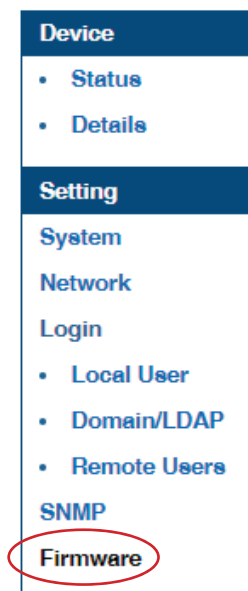

The screenshot shows a vertical navigation pane. The top section is "Device" with sub-items "Status" and "Details". The middle section is "Setting" with sub-items "System", "Network", "Login", "Local User", "Domain/LDAP", and "Remote Users". The bottom section is "SNMP" with the "Firmware" option circled in red.

< 3.6 > DHCP Setting

Step 8. Record the “ **MAC address** ”

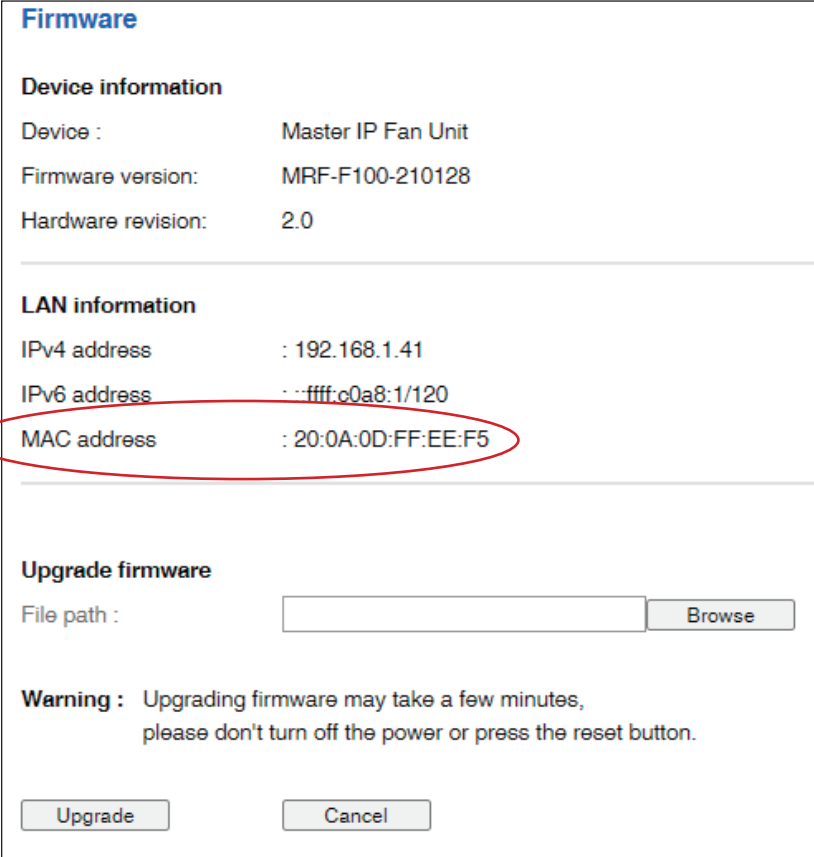

The screenshot shows a web-based interface for upgrading firmware. It is divided into three main sections: Device information, LAN information, and Upgrade firmware. The MAC address is highlighted with a red oval.

Device information	
Device :	Master IP Fan Unit
Firmware version:	MRF-F100-210128
Hardware revision:	2.0

LAN information	
IPv4 address	: 192.168.1.41
IPv6 address	: ::ffff:c0a8:1/120
MAC address	: 20:0A:0D:FF:EE:F5

Upgrade firmware

File path :

Warning : Upgrading firmware may take a few minutes,
please don't turn off the power or press the reset button.

Step 9. Assign an IP address to the Master IP Fan Unit from your DHCP server.

..... **Complete**

The company reserves the right to modify product specifications without prior notice and assumes no responsibility for any error which may appear in this publication.

All brand names, logo and registered trademarks are properties of their respective owners.

Copyright 2022 Austin Hughes Electronics Ltd. All rights reserved.