

User Guide

November 2009

CATx KVM Extender Range

Single Video Channel Kits

Model SDBX/S1

Model SDBX/D1

Model SDBX/SA1

Model SDBX/DA1

Single Video Channel Remote Units

Model SDBX/R1

Model SDBX/RA1

Dual Video Channel Remote Units

Model SDBX/R2

Model SDBX/RA2

Quad Video Channel Remote Units

Model SDBX/R4

Model SDBX/RA4

Dual Video Channel Kits

Model SDBX/S2**

Model SDBX/SA2**

*** Obsolete products. Now replaced by SDBX/S2-1 & SDBX/SA2-1 and covered in a separate User Guide*

Cautions and Notes

The following symbols are used in this guide:



CAUTION. This indicates an important operating instruction that should be followed to avoid any potential damage to hardware or property, loss of data, or personal injury.



NOTE. *This indicates important information to help you make the best use of this product.*

Copyrights and Trademarks

©2004/2009. All rights reserved. This information may not be reproduced in any manner without the prior written consent of the manufacturer.

Information in this document is subject to change without notice and the manufacturer shall not be liable for any direct, indirect, special, incidental or consequential damages in connection with the use of this material.

All trademark and trade names mentioned in this document are acknowledged to be the property of their respective owners.

Safety Precautions and Installation Guidelines

To ensure reliable and safe long-term operation please note the following installation guidelines:

- Do not use to link between buildings.
- Only use in dry, indoor environments.
- If the building has 3-phase AC power, try to ensure that equipment connected to the Local and Remote Units is on the same phase.
- Try not to route the CATx link cable alongside power cables.
- The use of shielded CATx cable is recommended to maintain compliance.
- Ensure that the system connected to the Local Unit is connected to power ground.
- Ensure that the monitor connected to the Remote Unit is connected to power ground and does not use an isolated power supply.
- The Remote Unit and any power supplies can get warm. Do not situate them in an enclosed space without any airflow.
- Do not place the power supply directly on top of the Remote Unit.
- Do not obscure the Remote Unit's ventilation holes.
- This product is not suitable for use in isolated medical environments.



To safeguard against personal injury and avoid possible damage to equipment or property, please observe the following:

- Only use power supplies originally supplied with the product or manufacturer-approved replacements. Do not attempt to dismantle or repair any power supply. Do not use a power supply if it appears to be defective or has a damaged case.
- Connect all power supplies to grounded outlets. In each case, ensure that the ground connection is maintained from the outlet socket through to the power supply's AC power input.
- Do not attempt to modify or repair this product, or make a connection from the CATx link interface (RJ45) to any other products, especially telecommunications or network equipment.

Contents

1. Quick Setup	5
Command Summary	6
2. Overview	7
Introduction	7
Glossary	7
Features	9
Product Range	10
Compatibility	11
How to Use This Guide	12
3. Installation	13
Package Contents	13
Interconnection Cable Requirements	14
Remote Unit Installation	15
Local Unit Installation	17
Connection to Rack Mount Hub Local Units	21
4. Remote Unit Configuration & Operation	24
Video Configuration Overview	24
Video Adjustments	25
Command Mode	26
Adjusting Video	27
Other Remote Configuration & Operation Options	32
5. Local Unit Operation	35
Overview	35
Dual Access Systems	36
6. Troubleshooting	38
Video	38
Keyboard & Mouse	40
Audio	41
Serial	41
General Questions	42

Appendix A: Example Applications	43
Appendix B: Rack Mount Options	48
Appendix C: Remote Unit: Flash Upgrading & External Configuration	50
Appendix D: Advanced Cabling Issues (Skew)	51
Appendix E: Audio/Serial Ports: Operation & Multi-Port Configuration	54
Appendix F: Obtaining Technical Support	56
Appendix G: Specifications	57
Appendix H: EU Regulatory Compliance	60
Appendix I: North American Regulatory Compliance	61
Appendix J: Disclaimer	61

1. Quick Setup

This section briefly describes how to install your KVM extender system and optimize the video signals. Unless you are an experienced user, we recommend that you follow the full procedures described in the rest of this manual. Refer to the command summary on the next page when following this procedure.

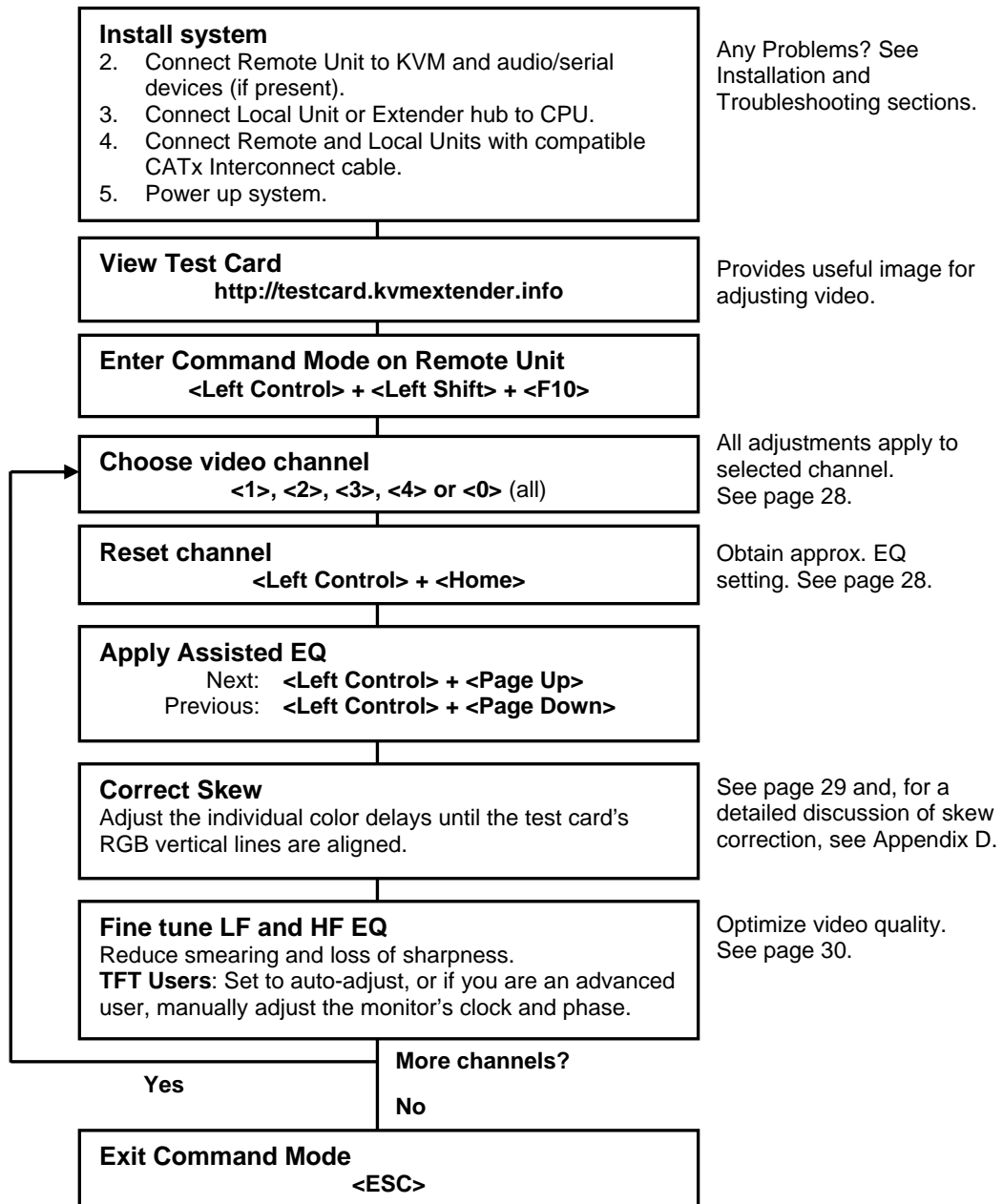

Command Summary

The following table summarizes the ‘hot’ key command sequences used in system configuration and video tuning on a Remote Unit console.

<i>Command Mode</i>	
Enter Command Mode	<Left Control> + <Left Shift> + <F10>
Exit Command Mode & Save	<ESC>
Exit Command Mode Without Save	<Left Control> + <ESC>
<i>Video Channel Selection</i>	
Select Channel For Adjustment	<1>, <2>, <3> or <4>
Select ALL Video Channels	<0>
<i>Assisted EQ</i>	
Next Assisted EQ Setting	<Left Control> + <Page Up>
Previous Assisted EQ Setting	<Left Control> + <Page Down>
Reset EQ & Delay Values	<Left Control> + <Home>
Reset EQ Values	<Left Control> + <End>
<i>LF/HF Equalization</i>	
Increase LF Equalization (Coarse)	<L> + <Up Arrow>
Increase LF Equalization (Fine)	<L> + <Right Arrow>
Decrease LF Equalization (Coarse)	<L> + <Down Arrow>
Decrease LF Equalization (Fine)	<L> + <Left Arrow>
Increase HF Equalization (Coarse)	<H> + <Up Arrow>
Increase HF Equalization (Fine)	<H> + <Right Arrow>
Decrease HF Equalization (Coarse)	<H> + <Down Arrow>
Decrease HF Equalization (Fine)	<H> + <Left Arrow>
<i>Quick Skew</i>	
Toggle RED Delay (19nS)	<Left Control> + <R>
Toggle GREEN Delay (19nS)	<Left Control> + <G>
Toggle BLUE Delay (19nS)	<Left Control> +
<i>Delay (Skew)</i>	
Increase RED Delay	<R> + <Right Arrow>
Increase GREEN Delay	<G> + <Right Arrow>
Increase BLUE Delay	 + <Right Arrow>
Decrease RED Delay	<R> + <Left Arrow>
Decrease GREEN Delay	<G> + <Left Arrow>
Decrease BLUE Delay	 + <Left Arrow>
<i>Reset Commands</i>	
Reset Mouse and Keyboard	<F1>
Mouse Recovery	<F3>
Set Extender To Default State	<Left Control> + <F9>
<i>Other Commands</i>	
Toggle Remote Unit Private Mode	<Scroll Lock>
Toggle Local Unit Initial Hot Key	<F7>
Local Unit Scroll Lock Key Mode	<F5>

2. Overview

Introduction

The SDBX product range enables high-resolution video, PS/2 keyboard and mouse, stereo audio, and serial port signals to be communicated up to 300m over Category 5, 5e, 6 or higher (CATx) cable.

A basic SDBX extension system comprises a *Local Unit* (transmitter) and a *Remote Unit* (receiver). The Local Unit connects directly to the computer (or a KVM switch system) using the supplied cable(s). The user *console* (keyboard, mouse and monitor) attaches to the Remote Unit. The Remote and Local Units communicate video and data information along the connecting CATx cable (Figure 1).

Within the product range, models are available with combinations of the following:

- Audio transmission: bi-directional stereo audio (16-bit digitized).
- Serial transmission: transparent serial COM port (to 19.2Kbps).
- Dual access: allowing a second user console at the Local Unit.
- Multiple video channels: single, dual (and quad) video heads.

Glossary

The following terms are used in this guide:

CATx	Any Category 5, 5e, 6 or higher cable.
PSU	Power Supply Unit.
KVM	Keyboard, Video and Mouse.
Console	A keyboard, monitor, and mouse, plus optional serial/audio devices.
Dual Access	A system allowing connection of local and remote user consoles.
Single Head	An extender system that supports one monitor.
Dual Head	An extender system that supports two monitors.
Quad Head	An extender system that supports four monitors.

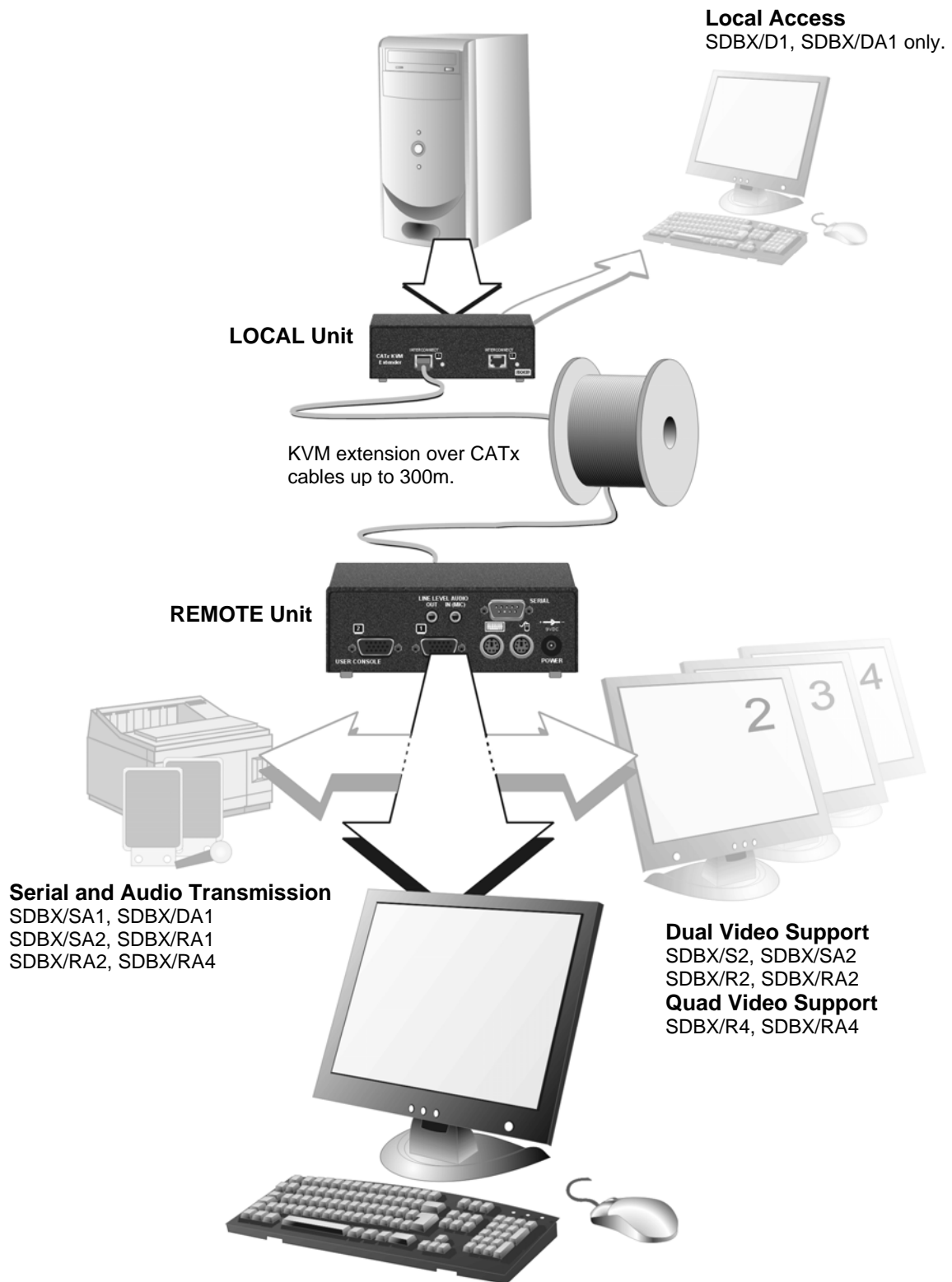

Figure 1 SDBX KVM extender system

Features

All members of the SDBX product family offer the following features:

- Support for high video resolution over extended distances:
1600x1200@60Hz over 200m
1280x1024@75Hz over 300m
Higher resolutions may be possible over shorter distances.
- Fully integrated skew compensation allows operation with CATx cables by canceling color shift and enhancing sharpness.
- Independent low frequency (LF) and high frequency (HF) cable equalization control ensures optimum video tuning across different cable types.
- Models available with single, dual and quad-head video support (one CATx cable required for each video channel).
- All control and video tuning carried out using the remote keyboard with settings stored in EEPROM memory.
- Remote Unit firmware and settings flash upgradeable.
- Intelligent PS/2 keyboard and mouse emulation ensures PCs do not lock-up and allows peripherals to be hot-plugged.
- Dual-Access models allow local or remote operation.
- DDC emulation in Local Unit ensures compatibility for all standard graphics modes.
- Transparent serial port (on certain models) enables any serial device to be extended (up to 19.2K Baud). The serial port may be used to extend one device (requiring handshaking lines), or up to three simple serial devices (no handshaking).
- Bi-directional stereo audio (16-bit digitized) support on certain models enables high-quality audio extension.
- Local Units are normally powered directly by the PC (or switch).
- Private Mode on dual-access models allows user to lock out other console.
- Status indicator LEDs on each RJ45 port.
- Small footprint chassis with rack mount options available.
- Surge protection on each RJ45 port.
- SDBX Remote Units are fully compatible with SDLink Local Units and SDRK Rack hubs.
- CPU cables included (certain models).

Product Range

There are twelve products in the range:

Single Video Channel Kits (Standard)

SDBX/S1	Single Video Channel, PS/2 KB & Mouse Local Unit (Single Access) + Remote Unit
---------	---

SDBX/D1	Single Video Channel, PS/2 KB & Mouse Local Unit (Dual Access) + Remote Unit
---------	---

Single Video Channel Kits (Audio)

SDBX/SA1	Single Video Channel, PS/2, Serial, Stereo Audio Local Unit (Single Access) + Remote Unit
----------	--

SDBX/DA1	Single Video Channel, PS/2, Serial, Stereo Audio Local Unit (Dual Access) + Remote Unit
----------	--

Dual Video Channel Kit (Standard)

SDBX/S2**	Dual Video Channel, PS/2 KB & Mouse Local Unit + Remote Unit (Dual Video)
-----------	--

Dual Video Channel Kit (Audio)

SDBX/SA2**	Dual Video Channel, PS/2, Serial, Stereo Audio Local Unit + Remote Unit (Dual Video)
------------	---

Remote Units With PS/2 Interfaces

SDBX/R1	Single Video Channel, PS/2 KB & Mouse
---------	---------------------------------------

SDBX/R2	Dual Video Channel, PS/2 KB & Mouse
---------	-------------------------------------

SDBX/R4	Quad Video Channel, PS/2 KB & Mouse
---------	-------------------------------------

Remote Units With PS/2, Serial and Audio Interfaces

SDBX/RA1	Single Video Channel, PS/2, Serial, Stereo Audio
----------	--

SDBX/RA2	Dual Video Channel, PS/2, Serial, Stereo Audio
----------	--

SDBX/RA4	Quad Video Channel, PS/2, Serial, Stereo Audio
----------	--

** Obsolete products. Now replaced by SDBX/S2-1 & SDBX/SA2-1 and covered in a separate User Guide.

Compatibility

Interface Compatibility

- **PS/2 Keyboard:** Compatible with all standard keyboards. Certain keyboards with enhanced features may also be supported with custom firmware.
- **PS/2 Mouse:** Compatible with all standard 2-button, 3-button and wheel mice. To connect to a PC that does not have a PS/2 mouse port, an active serial converter is required - Model: *Mdapt (PS/2)*.
- **Audio:** Input and output are line-level. Amplified speakers are required. A microphone may be directly connected to the Remote Unit (optional pre-amplification).
- **Serial:** Transparent up to 19.2K Baud (38.4K operation may be possible with some devices). The following serial signals are extended: TX, RX, RTS, CTS, DTR, DSR. In rare cases, a wiring adaptor may be required to transfer RI and DCD.
- **Video:** VGA to UXGA. Separate sync, composite sync, or sync-on-green. Maximum resolution and refresh rates depend on cable length and cable type (see **Appendix G: Specifications**, page 57).

Extender Compatibility

The SDBX range of CATx KVM extender products offer enhanced performance while maintaining complete compatibility with existing SDLink standalone and rack mount CAT5 extenders.

You can use SDLink and SDBX products belonging to the same family in any combination. However, it is not possible to mix Standard and Audio products within a system. SDBX units are not currently compatible with SDLink SUN or SDLink Serial (no audio) products.

<i>SDBX Standard Family</i>		<i>SDBX Audio Family</i>	
Standard family units are compatible with the following SDLink products:		Audio family units are compatible with the following SDLink products:	
SDLink1	SDLink2	SDLink1/AU	SDLink2/AU
SDLink/LC	SDLink/DM	SDLink/AM	SDLink/RA
SDLink2/SW	SDLink/RLC	SDLink/MAR	SDRK/6A
SDLink/R	SDLink/RSW	SDRK/6AD	SDRK/6RA
SDRK/6	SDRK/6D		
SDRK/12	SDRK/6R		

How to Use This Guide

This guide describes the installation and configuration of the SDBX range of KVM extenders. Although the connection and operation of the system is relatively straightforward, you should consider the following before getting started:

Connection & Compatibility

If you have purchased an *SDBX Extender kit*, this will contain all the cables required to connect the Local Unit to your PC or KVM switch. The remote console (keyboard, monitor and mouse) and any audio and serial equipment connect directly to the Remote Unit.

If you have purchased an *SDBX Remote Unit*, ensure that it is compatible with your Local Unit (see **Compatibility**, page 11).

For information about connection and installation, see **Installation**, page 13.

Interconnection Cable

You will need CATx (any category 5, 5e, 6 or higher) cable, terminated with RJ45 plugs, to connect the Local and Remote Units (see **Interconnection Cable Requirements**, page 14).

Adjusting Video

Video signals become distorted when transmitted over CATx cables. To get the best from your extender system, it is *essential* that you adjust the SDBX Remote Unit to optimize the video image quality.

- For experienced users, there is a **Quick Setup** section at the start of this guide (see page 5).
- For the full procedure, see **Remote Unit Configuration & Operation**, page 24.
- Refer to **Appendix D: Advanced Cabling Issues (Skew)**, page 51 for a more in depth discussion of skew correction and advanced cabling issues.

3. Installation

For first-time users we recommend that you carry out a test placement, confined to a single room, before commencing full installation. This will allow you to identify and solve any cabling problems, and experiment with the KVM extender system more conveniently.

Package Contents

You should receive the following items in your extender package. If anything is missing, please refer to **Appendix F: Obtaining Technical Support**, page 56.

- Extender Remote Unit.
- 9V DC universal power supply for Remote Unit.
- Extender Local Unit.
Only included in extender kits.
- KVM CPU combination cable (1.8m) with PS/2 (6-pin mini-DIN male-to-male) keyboard and mouse connectors and VGA video (HD15 male to female) connector.
Models: SDBX/S1, SDBX/D1, SDBX/SA1 and SDBX/DA1 only.
- KVM CPU combination cable (1.0m) with PS/2 (6-pin mini-DIN male-to-male) keyboard and mouse connectors, VGA video (HD15 male) connector, and 25-way (DB25 Female) extender connector.
Models: SDBX/S2 and SDBX/SA2 only.
- CPU video cable (1.0m) with VGA video (HD15 male) connector and a 25-way (DB25 Female) extender connector.
Models: SDBX/S2 and SDBX/SA2 only.
- Serial cable (1.8m, DB9 male/female connectors, 1:1 connections).
Models: SDBX/SA1, SDBX/DA1 and SDBX/SA2 only.
- Dual audio cable (1.8m, 3.5mm stereo plugs)
Models: SDBX/SA1, SDBX/DA1 and SDBX/SA2 only.
- IEC AC Power Cord.
- Quick Start Guide.

Interconnection Cable Requirements

To connect the Local and Remote Units you will need CATx (any category 5, 5e, 6 or higher) cable terminated with RJ45 plugs. Please note that shielded cable is advised to maintain regulatory EMC compliance.

Interconnect cables must be solid-core type. Stranded patch cable will give poor results over longer distances. The pairing of the cable and pinning of its connectors should normally be in accordance with EIA-568B (see page 52).

One CATx cable is required for each video channel.

- The *Primary* interconnect cable connects INTERCONNECT Port 1 on the Local and Remote Units. This carries the main video channel and all data (plus audio/serial).
- *Secondary* CATx cables (connected to INTERCONNECT Ports 2 - 4) carry additional video channels on multi-head units.



In order to send Keyboard, Mouse, Audio and Serial signals to the PC, the Primary interconnect must be connected.

The Primary interconnect does not have to be connected in order to use the keyboard attached to the Remote Unit for set-up. However, if the Primary interconnect is disconnected, the keyboard cannot be used for configuration for 15 seconds after disconnection (to maintain data integrity).

*With some cables, video performance may be improved by using a cross-over patch cable at each end or an alternative RJ45 pin-out (see **Appendix D: Advanced Cabling Issues (Skew)**, page 51).*

Remote Unit Installation

To install a Remote Unit:

1. Switch off all devices.
2. Connect your keyboard, monitor(s) and mouse to the Remote Unit as shown in Figure 2 (single and dual head units) or Figure 4 (quad head units).



These ports may also be attached to the CPU side of a KVM switch in order to have a remote CPU. However, if you are attempting to use the extender between cascaded KVM switches this may not work. Please contact Technical Support to discuss your application.

3. If appropriate, connect audio equipment and serial devices. Connect the audio cables as follows:

<i>Remote Unit</i>	<i>Audio Device</i>
Audio Out	Speakers
Audio In (MIC)	Microphone

See **Appendix E: Audio/Serial Ports: Operation & Multi-Port Configuration**, page 54 for further information.

4. Connect the Primary CATx cable to the INTERCONNECT (1) socket on the front of the Remote Unit. For Dual and Quad systems, connect additional CATx cables as required (see Figure 3 and Figure 5).
5. Connect the 9V power supply to power the unit.



Only use the power supply originally supplied with this equipment or a manufacturer approved replacement.

NEVER CONNECT THE REMOTE UNIT 9V POWER SUPPLY TO A LOCAL UNIT: YOU WILL DAMAGE THE EXTENDER SYSTEM.

Choose a well-ventilated location for a quad head unit. When in use, these can generate a considerable amount of heat.

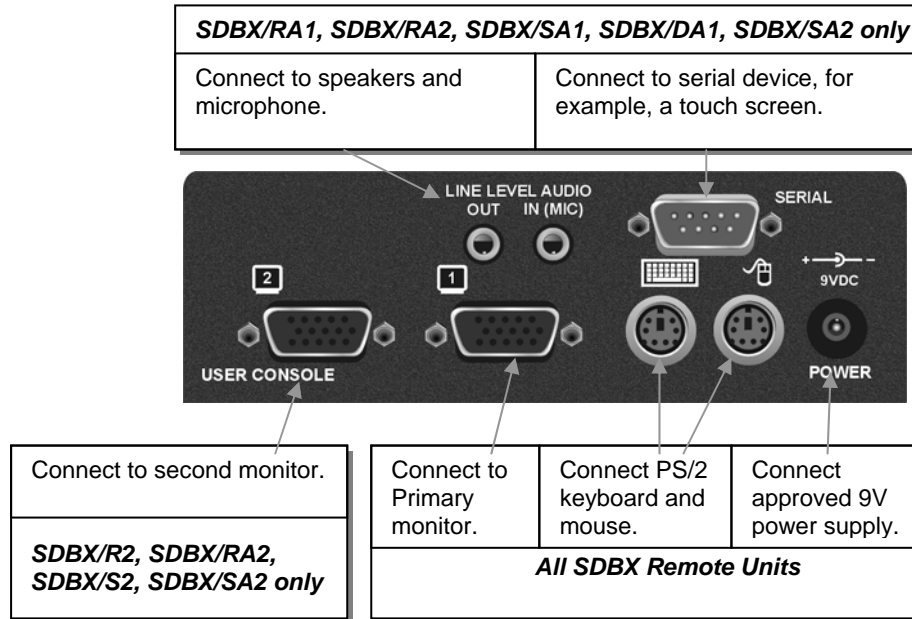
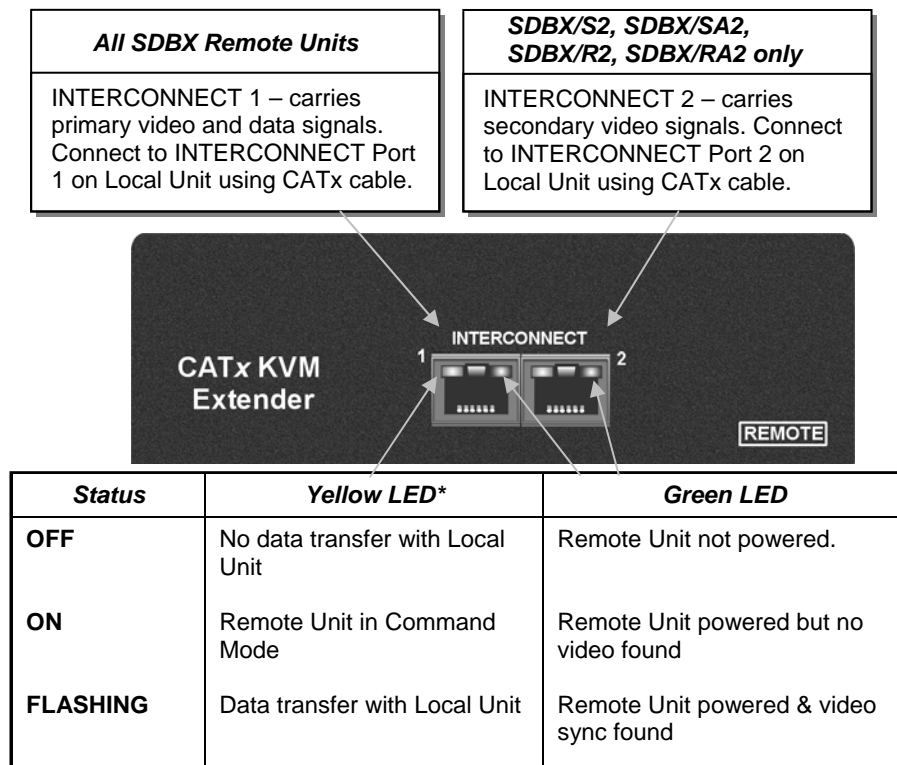

Figure 2 Single/Dual Head Remote Unit – rear view



* Yellow LED active on primary INTERCONNECT socket (Channel 1) only

Figure 3 Single/Dual Head Remote Unit - front view

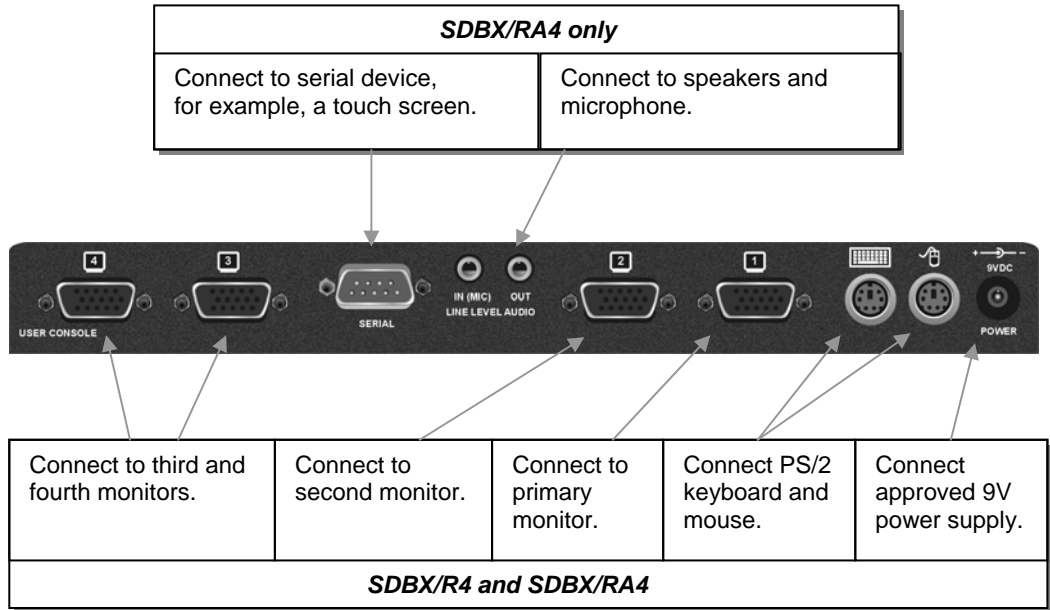
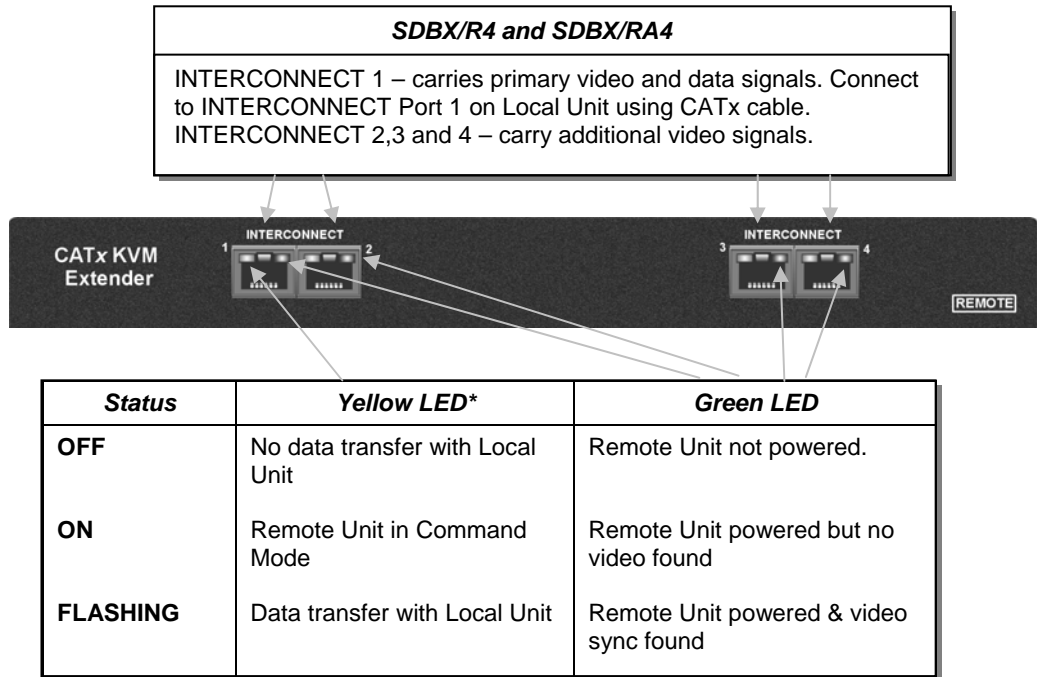

Figure 4 Quad Head Remote Unit – rear view



* Yellow LED active on primary INTERCONNECT socket (Channel 1) only

Figure 5 Quad Head Remote Unit - front view

Local Unit Installation

To install a Local Unit:

1. It is recommended that the PC and other devices are switched off before connection.
2. Using the supplied CPU KVM cable(s), connect the keyboard, monitor(s) and mouse connectors on the computer (or KVM switch) to the corresponding connectors on the Local Unit as shown in Figure 6 for single video units, or Figure 7 for dual video units.

Ensure that you attach the keyboard and mouse connectors to the correct ports. The keyboard connector is purple; the mouse connector is green.



If your PC does not have a PS/2 mouse port, an active serial converter will be required - Model No: Mdapt (PS/2).

3. If you have a dual access system, connect the keyboard, mouse and monitor for the local console to the appropriate ports on the Local Unit. The ports may also be used to feed into a KVM switch.
4. If you have an audio and serial enabled system, connect the audio cables between the computer and Local Unit as follows:

<i>Computer</i>	<i>Local Unit</i>
Audio Out (green)	Audio In
Audio In/Microphone (pink)	Audio Out

5. If appropriate, connect the supplied serial cable between the serial port on the computer and the Local Unit.
6. For single video units, connect the CATx cable to the INTERCONNECT socket on the front of the Local Unit. For dual or quad systems, connect CATx cables from the Remote Unit to the corresponding INTERCONNECT ports (1,2,3 & 4) on the Local Unit.
7. Power up the PC.



The Local Unit normally takes power through the PC's keyboard port. In video only applications, this connection is not used and so an external PSU is required.

Models SDBX/S2 and SDBX/SA2 have a port for an optional 5V power supply. Models SDBX/S1, SDBX/D1, SDBX/SA1, and SDBX/DA1 require a 5V PSU with a MiniDIN connector to be plugged into the extender's keyboard port.

Please contact Technical Support to obtain a suitable power supply.



NEVER CONNECT THE REMOTE UNIT 9V POWER SUPPLY TO A LOCAL UNIT: YOU WILL DAMAGE THE EXTENDER SYSTEM.

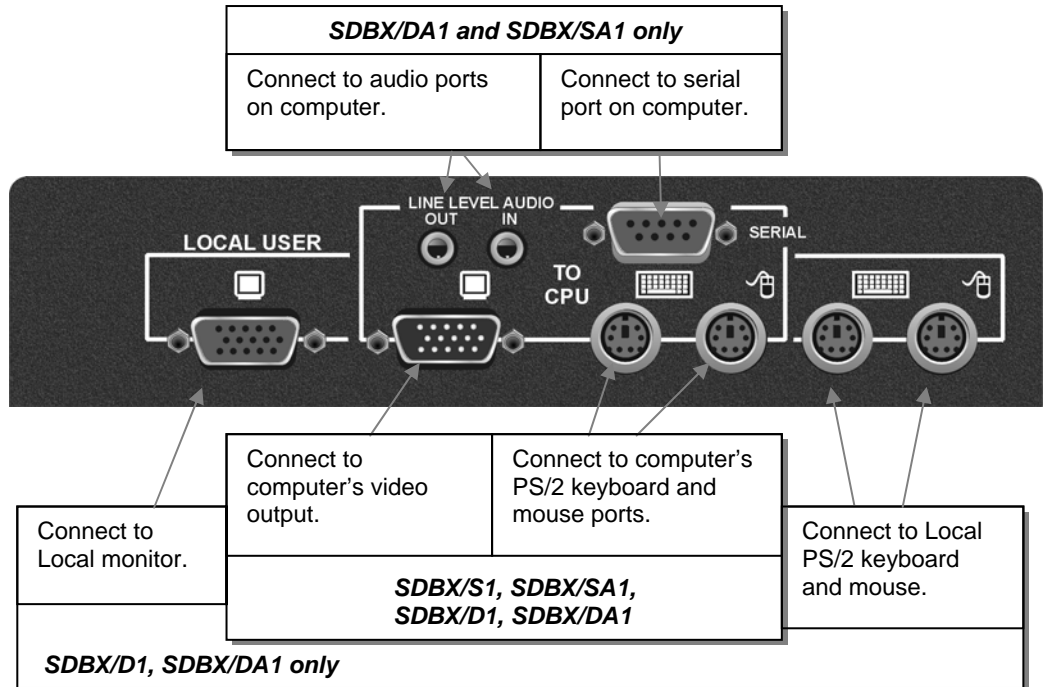

Figure 6 SDBX Local Unit (Single Video) - rear view

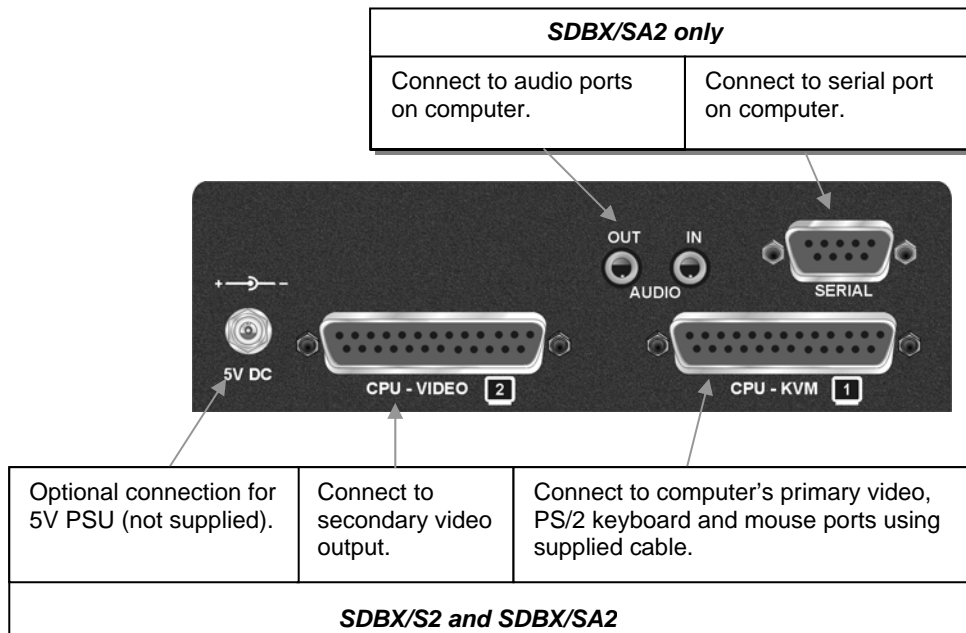

Figure 7 SDBX Local Unit (Dual Video) - rear view

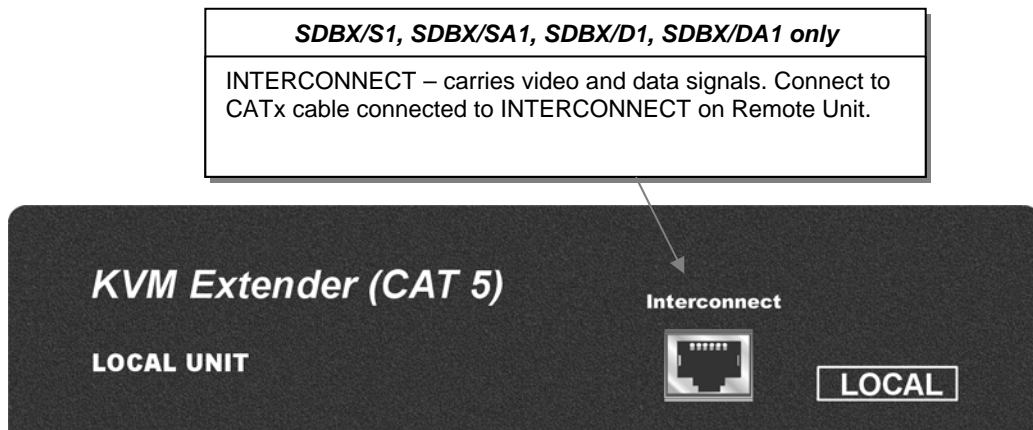

Figure 8 SDBX Local Unit (Single Video) – front view

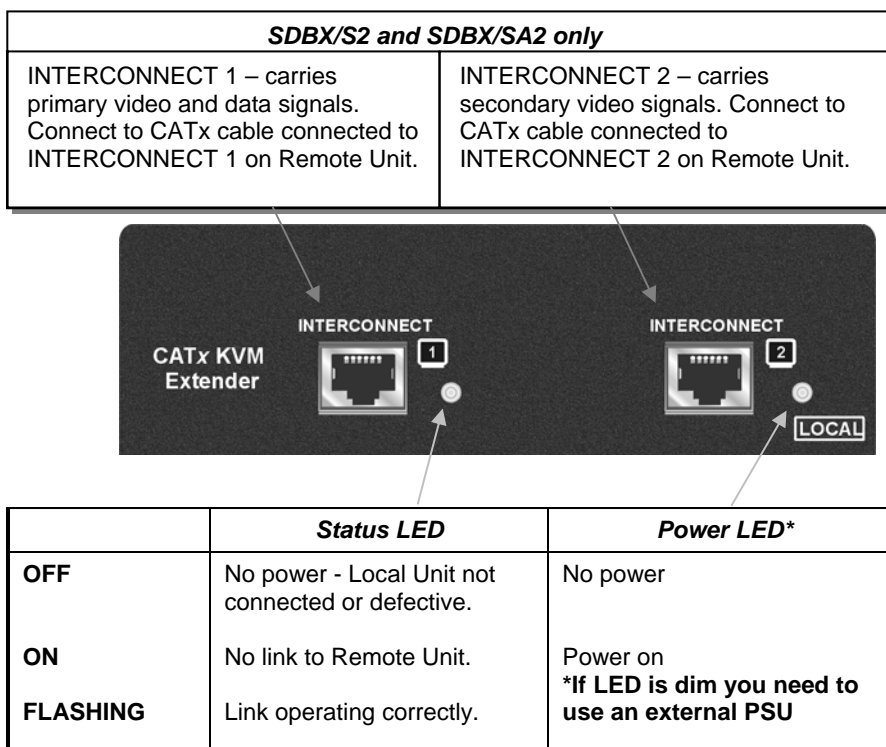

Figure 9 SDBX Local Unit (Dual Video) – front view

Connection to Rack Mount Hub Local Units

SDBX Remote Units are compatible with SDRK Rackmount Extender Hub Local Units belonging to the same family:

<i>SDBX Remote Units</i>	<i>Compatible Local Rack Hubs</i>
SDBX/R1, SDBX/R2, SDBX/R4	SDRK/6, SDRK/6D, SDRK/12
SDBX/RA1, SDBX/RA2, SDBX/RA4	SDRK/6A, SDRK/6AD

You can use Rack Extender Hubs in a number of ways:

- Individually, connecting a single-head SDBX Remote Unit to each port (see Figure 10)
- With multi-head SDBX Remote Units, using adjacent hub ports to transmit the primary video/data and secondary video signals (see Figure 11).

For more complex examples showing the use of Rack Extender Hubs with SDBX Remote Units in efficient ways, see **Appendix A: Example Applications**, page 43. Additional video channels do not require the Extender Hub to be of the same family. For example, an SDRK/12 could be efficiently used to transmit multiple secondary video channels to SDBX/RA2 units.



Individual Rack Hub operation is not covered in this guide. Please refer to the documentation supplied with your Rack Hub unit.

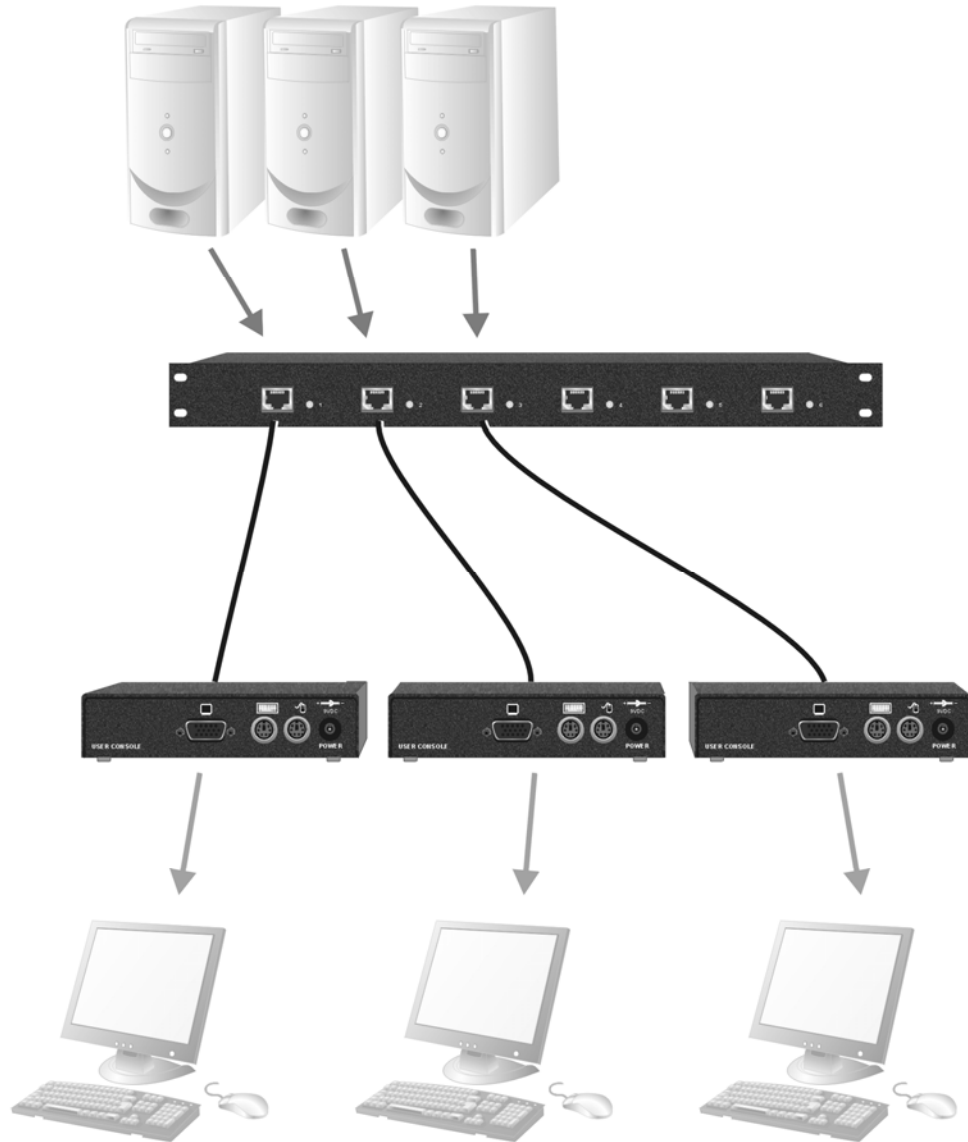

Figure 10 Simple system using SDRK/6 Hub and SDBX/R1 Remote Units

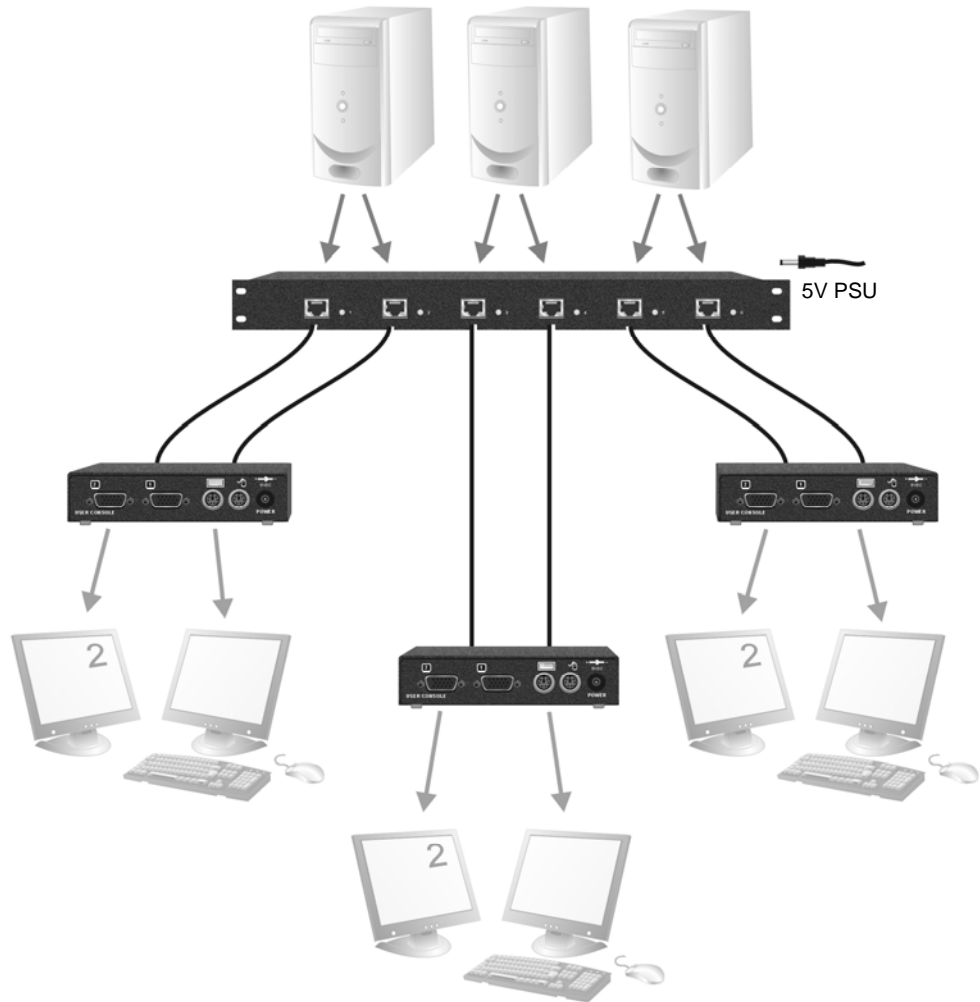

Figure 11 SDRK/6 Hub used with SDBX/R2 units to extend dual video

4. Remote Unit Configuration & Operation

Cat5/5e/6 cables are specifically designed for networking applications and not for transmitting analog video. Your CATx KVM extender includes, and requires, advanced technology to enable its use at high screen resolutions. This section describes how to optimize the video signal, configure the Extender system and operate the Remote Unit.

For details about flash upgrading and external configuration see **Appendix C: Remote Unit: Flash Upgrading & External Configuration**, page 50.

For information about serial/audio port operation, see **Appendix E: Audio/Serial Ports: Operation & Multi-Port Configuration**, page 54.

Video Configuration Overview

To get the best out of your extender system it is *essential* that you configure it correctly and tune the video signal. Tuning is necessary because of distortions that occur in a video signal when it is transmitted over lengthy CATx cables. Generally, you only need to carry out this procedure after installation.

The system stores settings in an EEPROM in the Remote Unit and restores them whenever the unit is powered up.

When you have installed your extender system, run an application that requires a high screen resolution. Examine the video image on the remote console's monitor. You may see some of the following distortion effects:



Smearing: black smearing at the right-hand edge of large horizontal objects such as title bars and characters. To correct this smearing requires adjustment of *LF equalization*.



Loss of Sharpness: Loss of high frequency (HF) signals causes blurring and lack of detail. To correct this requires adjustment of *HF equalization*.



Color Separation or Skew: This arises because of timing differences in the reception of signals for the individual colors. Each color in the RGB (Red, Green, Blue) video signal is sent down a separate pair of wires in the Interconnect cable.

On many cables, the twist rates differ and this leads to each color arriving at a slightly different time and therefore spreading out on the screen. Skew becomes a major problem at high screen resolutions and with long CATx cables. To correct for skew, the 'faster' colors must be delayed to arrive at the same time as the slowest.

Video Adjustments

SDBX Remote Units feature a number of correction tools to simplify video optimization. This procedure is straightforward and only needs to be carried out once.

For each video channel, the Remote Unit allows you to optimize independently:

- Low frequency (LF) equalization
- High frequency (HF) equalization
- Red delay
- Green delay
- Blue delay

To help automate the procedure, the SDBX Remote Unit offers the following unique tools:

- **Assisted EQ:** Allows you to ‘step-through’ a table of preset LF and HF EQ values for different cable lengths.
- **Quick Skew:** Inserts a standard delay on a specified color (19ns - a typical value suitable for most applications).
- **Channel 0:** Allows you to apply video adjustments to all video channels simultaneously (multi-head units only).

To get the best video image, you are recommended to follow the procedures for manual fine-tuning (see **Adjusting Video**, page 27).



*You may want to read **Appendix D: Advanced Cabling Issues (Skew)** on page 51 to understand how to achieve optimum video quality with your particular CATx interconnection cable.*

Command Mode

During normal use, the remote console keyboard functions in the usual manner. However, by using a specific ‘hot’ key sequence, you can set the keyboard into a Command Mode. From this, you can use various keys and key combinations to tune the video signal and generally configure the extender system.

To enter Command Mode:

1. Ensure that you have installed and powered up the system according to the instructions in the Section 2.
2. Press the following key combination on the remote keyboard:
<Left Control> + <Left Shift> + <F10>
3. From Command Mode, you can use one or more of the ‘hot’ key sequences shown on page 6 to configure the system. The next section gives a full description of the video optimization procedure.

To exit Command Mode:

Press <Esc> to exit Command Mode and save the settings. Alternatively, press <Left Control> + <Esc> to exit command mode without saving changes made in the current session.

The Remote Unit automatically times out Command Mode after 30 sec of inactivity, saves all settings to EEPROM and returns normal function to the keyboard.



Status LEDs in Command Mode

In Command Mode, the Remote Unit:

- Illuminates the yellow channel 1 LED continuously (see Figure 9). Note. The Yellow LEDs on other video channels are not lit.
- Flashes the status LEDs (Num Lock, Caps Lock, Scroll Lock) on the connected keyboard to indicate video channel selection (to which adjustments will be applied).

The number of flashes indicates the selected video channel:

<i>Keyboard LED flashes</i>	<i>Video channel</i>
1	Channel 1 (default)
2	Channel 2 (Dual and Quad systems only)
3	Channel 3 (Quad systems only)
4	Channel 4 (Quad systems only)
Slow Flashes	All channels simultaneously (<i>Channel 0</i>)

Adjusting Video

Use the following step-by-step procedure to optimize the video image on the remote console:

1. If possible, view the online test card at:

<http://testcard.kvmextender.info>

This is an image (see Figure 12) created and used by the manufacturer for video optimization purposes. It is particularly useful for correcting skew. If you are unable to view the test card, display some text in a large font on a white background.

 *You should also open up other application windows to check the clarity of text in tool bars and icons on the desktop.*

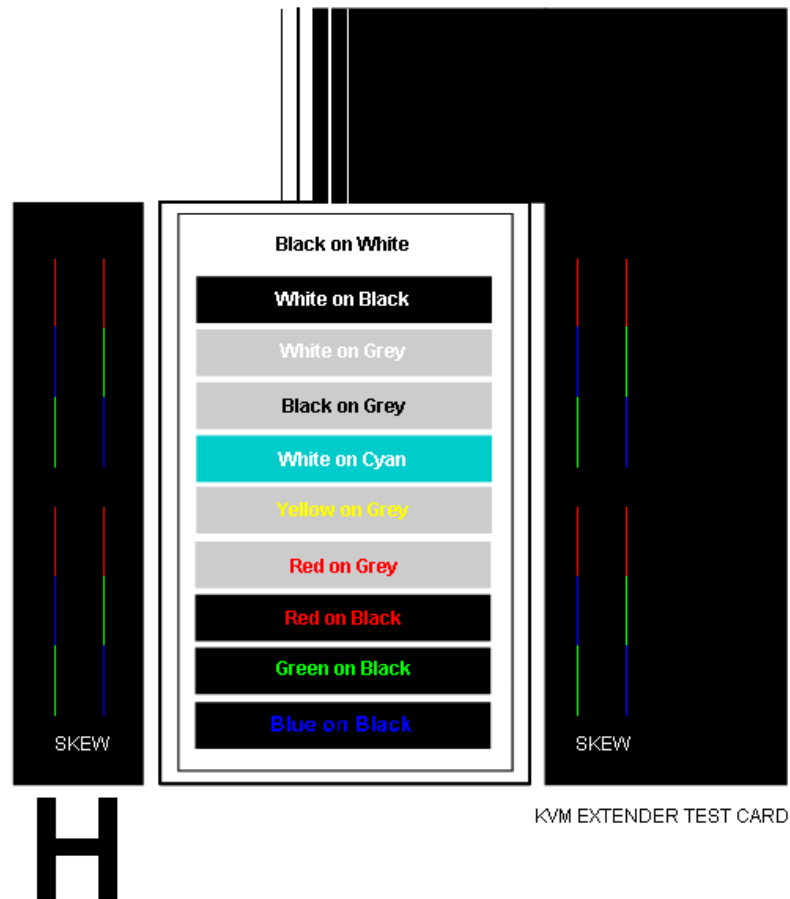

Figure 12 On-line test card available at <http://testcard.kvmextender.info>

2. Enter Command Mode (see **Command Mode**, page 26) by pressing the following key combination on the remote console's keyboard:

<Left Control> + <Left Shift> + <F10>

3. Select the video channel you want to configure using one of the following keys (*not* on the numeric keypad):

<i>Channel Command</i>	<i>Key</i>
Select Channel 1 For Adjustment	<1> (<i>default</i>)
Select Channel 2 For Adjustment	<2>
Select Channel 3 For Adjustment	<3>
Select Channel 4 For Adjustment	<4>
Select ALL Video Channels	<0> (<i>Channel 0</i>)



Use **Channel 0** to tune all video channels simultaneously. This simplifies the procedure for setting up large multi-head installations where a consistent cable type is used and the adjustments required should be almost the same.

4. Reset the selected channel(s) by pressing:
<Left Control> + <Home>
5. Step through the *Assisted EQ* settings to find the level that gives the best image.

<i>Assisted EQ Command</i>	<i>Key Sequence</i>
Next Assisted EQ Setting	<Left Control> + <PgUp>
Previous Assisted EQ Setting	<Left Control> + <PgDn>



Assisted EQ steps through a table of preset LF & HF EQ values for different lengths of cable (in 25m increments calibrated from 0 to 375m). Each time you enter Command Mode and start adjusting Assisted EQ, the unit resets LF and HF values.

After finding the best setting, you will probably want to fine-tune the LF and HF equalization settings (see steps 8&9). This is best done after adjusting for any color skew as described below.

6. Identify the 'slowest' color – the colored line furthest to the right. Delay the signals of the two other colors using the following commands:

<i>Delay Command</i>	<i>Key Sequence</i>
Increase RED Delay (move right)	<R> + <Right Arrow>
Decrease RED Delay (move left)	<R> + <Left Arrow>
Increase GREEN Delay (move right)	<G> + <Right Arrow>
Decrease GREEN Delay (move left)	<G> + <Left Arrow>
Increase BLUE Delay (move right)	 + <Right Arrow>
Decrease BLUE Delay (move left)	 + <Left Arrow>

Use the *Quick Skew* feature to determine which color requires delaying or to quickly set the delay on a color back to zero. Applying *Quick Skew* to a color toggles its delay between zero and 19nS (a typically required value).

<i>Quick Skew Command</i>	<i>Key Sequence</i>
Toggle RED Delay	<Left Control> + <R>
Toggle GREEN Delay	<Left Control> + <G>
Toggle BLUE Delay	<Left Control> +

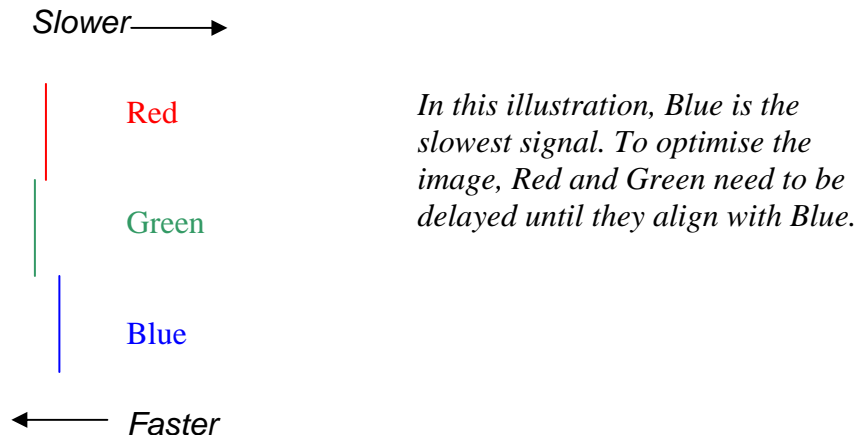



Figure 13 Illustration of skew and appearance on test card

 Some Cat5e/Cat6 cables require a large green delay. Video quality can often be vastly improved by using a standard cross-over patch cable at each end of the link rather than a straight patch cable. For details see **Appendix D: Advanced Cabling Issues (Skew)**, page 51.

Sometimes the optimum skew adjustment will actually be one step out from that suggested by the test card due to the way some monitors sample the signal.

The maximum amount of skew correction available is 42nS. This is more than adequate for the vast majority of cables. However, it may not be enough if you are using a particularly long run of a cable which exhibits severe delay skew.

7. If you are using one or more flat panel monitors in the remote consoles, carry out auto-adjustment as described in the monitor's documentation. Sometimes manual adjust of clock and/or phase is also required for optimum results and minimization of jitter.
8. Optionally, fine-tune the LF equalization to remove 'black video smearing' - black smears to the right of large objects such as window title bars and characters (see Figure 14).

<i>LF Equalization Commands</i>	<i>Key Sequence</i>
Increase LF Equalization (Coarse)	<L> + <Up Arrow>
Decrease LF Equalization (Coarse)	<L> + <Down Arrow>
Increase LF Equalization (Fine)	<L> + <Right Arrow>
Decrease LF Equalization (Fine)	<L> + <Left Arrow>

9. Optionally, fine-tune the HF equalization to sharpen the video image. Increase HF Equalization until a white edge to the right of small characters just starts to appear (see Figure 14).

<i>HF Equalization Commands</i>	<i>Key Sequence</i>
Increase HF Equalization (Coarse)	<H> + <Up Arrow>
Decrease HF Equalization (Coarse)	<H> + <Down Arrow>
Increase HF Equalization (Fine)	<H> + <Right Arrow>
Decrease HF Equalization (Fine)	<H> + <Left Arrow>



On certain monitors, you may obtain a sharper image by overcompensating HF EQ and then decreasing LF EQ to remove any bright streaks.

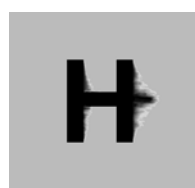

LF too low



LF too high



HF too low



HF too high

Figure 14 Problems with smearing and sharpness requiring LF or HF adjustment

10. If you are using one or more flat panel monitors in the remote consoles, carry out auto-adjustment again.
11. Save the settings by pressing the <Esc> key. Alternatively, to discard any changes and revert to the settings stored in the EEPROM, press <Left Control> + <Esc>. The Remote Unit automatically exits Command Mode after 30 sec of inactivity and saves all settings, including any changes.

Other Remote Configuration & Operation Options

Reset Commands

The SDBX range has a number of commands to reset the keyboard and mouse, to reset EQ and Delay values and to restore the factory default configuration.

<i>Command</i>	<i>Key Sequence</i>
<i>Reset Mouse and Keyboard</i>	<i><F1></i>
Resets the remote console's keyboard and mouse and then automatically exits Command Mode. You may need to do this if you have hot-plugged a keyboard or mouse and it has not initialized correctly.	
<i>Mouse Recovery</i>	<i><F3></i>
Use this command if you experience erratic movement of the mouse pointer or you have lost mouse movement after hot plugging the Local Unit into the CPU. In the case of erratic mouse movement, you may need to enter the command a number of times to re-synchronize the mouse signal. Alternatively, stop moving the mouse for a few seconds and the operating system's mouse drivers may automatically re-synchronize the signal. If the Local Unit has been hot-plugged, this command will issue a request to the OS to initialize the mouse. <i>Use this command with care.</i>	
<i>Reset EQ Values</i>	<i><Left Control> + <End></i>
You can use this command to zero HF & LF EQ values for the selected video channel(s). Current color delay values are not affected.	
<i>Reset EQ & Delay Values</i>	<i><Left Control> + <Home></i>
Set all video EQ (HF & LF) and color delay values to zero for the currently selected video channel(s).	
You can use this command to reset EQ and delay values for all video channels by selecting <i>Channel 0</i> prior to issuing this command.	
<i>Set Extender To Default State</i>	<i><Left Control> + <F9></i>
Sets ALL extender settings (video & configuration) back to the factory defaults and then exits Command Mode.	

Private Mode Commands

On dual-access SDBX systems, the remote user can lock out the local console by triggering a 'Private Mode' function. This prevents the local console from being used even if the two-second inactivity timeout period expires.

To lock out the Local Unit:

1. Enter Command Mode:

<Left Control> + <Left Shift> + <F10>

2. Press the **<Scroll Lock>** key on the Remote Unit keyboard.

To indicate that the Private Mode session is active, the extender system:

- Slowly flashes the Scroll Lock LED on the remote keyboard.
- Illuminates all three LEDs on the local keyboard.
- Displays a blank image on the local console's monitor.
- Locks the local console's keyboard and mouse.

To cancel the Private Mode, press **<Scroll Lock>** again while in Command Mode. This command also closes Command Mode.



*This command only applies to operation with Local Units (standalone and rack) which have firmware versions 'S50' and above. The firmware-revision level is printed on the base of the extender unit (see **Appendix F: Obtaining Technical Support**, page 56).*

Local Unit Configuration Commands

On dual-access SDBX systems, a local console user can lock out the remote console (see **Local Console Commands**, page 37). The SDBX system has two commands for configuring this feature from the remote console:

<i>Command</i>	<i>Key Sequence</i>
<i>Local Unit Initial Hot Key</i>	<i><F7></i>
<p>For Local Unit firmware versions ‘S50’ and above only (all SDBX range and SDLink with Audio/Serial)</p> <p>To disable the remote console (and start a Private mode session) a local console user must press an initial ‘hot’ key followed by <Scroll Lock>. By default, the initial ‘hot’ key is <Right Control> but this can be changed to <Left Control> from within Command Mode. The setting is stored in EEPROM.</p> <p>To toggle the Local Unit initial ‘hot’ key, enter Command Mode and then press <F7>. The console automatically exits from Command Mode after you use this command.</p>	
<i>Local Unit Scroll Lock Key Mode</i>	<i><F5></i>
<p>For Local Unit firmware versions below ‘S50’ only (for example, SDLink2, SDRK/6D, and SDLink/DM)</p> <p>In firmware versions earlier than ‘S50’, a local console user can disable the remote console (and start a Private mode session) simply by pressing <Scroll Lock>. An initial ‘hot’ key is not required. In these cases, the Scroll Lock key is not passed to the CPU. From within Command Mode, you can restore normal Scroll Lock operation. This disables the Private mode feature on the local console.</p> <p>To toggle between Private mode and normal Scroll Lock key operation on the local console, press <F5>. The setting is stored in EEPROM. The console automatically exits from Command Mode after you use this command.</p> <p> <i>On the remote console, the Scroll Lock key will always function as normal. However, the Scroll Lock LED is used to show Private Mode status. If the Scroll Lock key is assigned to Private Mode (default), then the remote console’s Scroll Lock LED will not light when <Scroll Lock> is pressed.</i></p>	

5. Local Unit Operation

Overview

You need to read this section if you have purchased an SDBX extender system kit containing both a Local and Remote Unit.

For more information about serial/audio port operation, see **Appendix E: Audio/Serial Ports: Operation & Multi-Port Configuration**, page 54.

Keyboard and Mouse Emulation

SDBX Local Units have keyboard and mouse emulation. The attached PC operates normally without requiring a keyboard or mouse to be attached to either the Remote or Local Units (in the case of a dual access system). You can therefore replace any keyboard or mouse attached to the extender system without disrupting the operation of the computer.

Power



NEVER CONNECT THE REMOTE UNIT 9V POWER SUPPLY TO A LOCAL UNIT: YOU WILL DAMAGE THE EXTENDER SYSTEM.

Single Head Video

Local Units normally take power from the keyboard connection to the computer. For video only applications, you must apply external power through this port. Use an external 5V PSU with PS/2 connector (Model: SDLink/PSL).

Dual Head Video

Local Units (SDBX/S2 and SDBX/SA2) may require an external 5V PSU (Model: SDLink/PSK):

- For video only applications.
- If the PC cannot provide sufficient power through the keyboard connection. If this is the case, the power LED on the front of the Local Unit will be dim (See Figure 9).

Contact Technical Support for further information.

Dual Access Systems

SDBX/D1 and SDBX/DA1 models offer dual access from consoles at both Remote and Local Units. This operates on a first-come, first-served basis. When one console is in use, the system blocks out the other console until there is no keyboard or mouse use at the active console for two seconds. Both monitors show the current activity on the computer irrespective of which console is in use.

Certain commands are available at the Local Unit.

To enter these commands:

1. Press and release the initial 'hot' key.
By default, the initial 'hot' key is <**Right Control**>
2. Press and release the command key.

Changing the Initial Hot Key

The Local Unit's initial 'hot' key may be toggled between <**Right Control**> and <**Left Control**> by entering a configuration command on the remote keyboard (See **Local Unit Configuration Commands**, page 34).

Local Console Commands

After pressing the initial ‘hot’ key on the local keyboard, you can issue a number of commands by pressing additional keys. These commands allow you to start a private mode session on the local console or to reset the keyboard and mouse.



These commands only apply to Local Units and Rack hubs having firmware versions ‘S50’ and above.

Command	Key Sequence
<p><i>Private Mode</i></p> <p>SDBX Local Units that feature dual access (SDBX/D1, SDBX/DA1) allow the local user to lock out the remote console by triggering a ‘Private Mode’ function. This prevents the remote console from being used even if the two second inactivity timeout period expires.</p> <p>During a Private Mode session, the extender system:</p> <ul style="list-style-type: none"> • Flashes the Scroll Lock LED on the local keyboard. • Illuminates all three LEDs on the remote keyboard. • Displays a blank image on the remote console’s monitor. • Locks the remote console’s keyboard and mouse. 	<p><i><Scroll Lock></i></p>
<p><i>Reset Local Keyboard and Mouse</i></p> <p>Reset the local console’s keyboard and mouse. You may need to do this if you have hot-plugged a keyboard or mouse and it has not initialized correctly.</p>	<p><i><Num-Pad Up Arrow></i></p>
<p><i>Mouse Recovery</i></p> <p>Use this command if you experience erratic movement of the mouse pointer or you have lost mouse movement after hot plugging the Local Unit into the CPU. In the case of erratic mouse movement, you may need to enter the command a number of times to re-synchronize the mouse signal. Alternatively, stop moving the mouse for a few seconds and the operating system’s mouse drivers may automatically re-synchronize the signal. If the Local Unit has been hot-plugged, this command will issue a request to the OS to initialize the mouse. <i>Use this command with care.</i></p>	<p><i><Num-Pad Left Arrow></i></p>

6. Troubleshooting

Video

The image is not sharp, or is badly smeared.

Have you adjusted the video equalization? Follow the instructions on page 24.

Check the Interconnect cable between the Remote and Local Units. Is it of the recommended type (see page 14)? Is it intact along its entire length and securely connected at both ends? Is it wired correctly (see page 52)?

Ensure that all video connections throughout the system are attached securely.

Are you using an LCD panel? You need to adjust its clock and/or phase.

Colors appear to be separated and there are colored borders on text and icons.

Have you tuned the video signal and set delays to correct skew? Follow the instructions on page 24. See Appendix D for advanced cabling information.

Check the Interconnect cable between the Remote and Local Units. Is it of the recommended type (see page 14)? Is it intact along its entire length and securely connected at both ends? Is it wired correctly (see page 52)?

I can't get enough color delay to correct skew

See **Appendix D: Advanced Cabling Issues (Skew)**, page 51.

I can't get rid of bright 'ringing' after characters

See **Appendix D: Advanced Cabling Issues (Skew)**, page 51.

I only need video extension – not keyboard or mouse - but I can't get a picture

Have you powered the Local Unit? The Local Unit gets its power from the CPU through the keyboard connection and it will not operate without it. Use an external 5V PSU as described on page 35.

The monitor sometimes goes blank for a second or two.

Check that the interconnect cable is not routed near power lines or other sources of electrical interference. Use shielded STP/FTP cable instead of UTP cable ensuring that the shield connection is maintained between the extender units.

Check system grounding. The Remote Unit has an isolated power supply and relies on obtaining a ground reference through the connected monitor. Some monitors on the market have an external PSU which itself may be isolated from power ground. If this is the case, and you are experiencing monitor blanking, you may need to consider grounding the Remote Unit chassis (to power ground) or replacing the monitor's power supply with a non-isolated model.

If this is a persistent problem, contact Technical Support.

The PC won't boot into the correct graphics mode

The extender includes DDC emulation for all standard resolutions and there should not normally be any issues.

For non-standard resolutions, you will need to explicitly set the resolution in your operating system configuration ignoring the DDC data read from the Local Unit.

Contact Technical Support if you have problems selecting your required graphics mode.

Jitter is evident on video.

Adjust the clock and/or phase on your flat-panel. Contact Technical Support if this fails to improve the situation.

Are you testing a system using a coiled drum of CATx cable? Try uncoiling the cable. If this solves the video jitter, you should not have a problem after full installation.

The image is not stable and is blanking regularly.

Re-power the Remote Unit.

Can the extender be used with RGB video?

Yes.

There is a slight color change when I increase delays to correct skew.

With certain monitors, there may be a *slight* color change when you increase the color delay. This is due to a contrast change on that particular color and may easily be compensated for by adjusting the monitor's color balance.

Keyboard & Mouse

When I am typing, I get wrong or missing characters on the screen.

Your keyboard may be in the wrong mode. Use the appropriate commands to reset the keyboard and mouse as described in the sections covering local and remote operation.

The PC comes up with 'keyboard error'.

Press <F1> or <ESC>. If the keyboard now operates correctly, you need to adjust the BIOS setup to disable keyboard testing during booting.

The system does not detect a PS/2 mouse.

If connecting the Local Unit to a live system, connect the mouse cable to the CPU *before* keyboard connection to ensure the mouse is enabled correctly. Try issuing the Mouse Recovery command. Check that the mouse cable is connected properly and securely. Reboot the system.

The mouse pointer moves erratically.

Reset the keyboard and mouse.
Issue the Mouse Recovery command up to three times.
Ensure that you have the latest driver for your mouse.
If you are using the extender with a KVM switch, command the switch to reset the mouse.
Quit and restart the application. Reboot the PC.

When I 'hot-plug' the Local Unit, the mouse no longer moves.

When connecting the Local Unit to a live system, connect the mouse cable to the CPU before keyboard connection to ensure the mouse is enabled.
Try issuing the Mouse Recovery command.

Some of the mouse buttons don't work.

The SDBX range supports standard 2/3-button mice (with or without a wheel). Additional buttons will not operate.

I have an enhanced keyboard with extra keys and indicators. Everything works apart from these additional features.

The extender emulates a generic PS/2 keyboard. To support other keyboards (or cascaded KVM switches), special firmware offering a *transparent mode* may be required. Please contact Technical Support to discuss your application.

Audio

The audio is very quiet.

The audio I/O is line-level and requires amplified speakers and connection to devices providing line-level I/O.

The audio is loud but distorted.

Check that the audio input is not greater than line level (4V peak-to-peak). The KVM extender accepts line-level audio input only.

The microphone output is barely audible.

See **Appendix E: Audio/Serial Ports: Operation & Multi-Port Configuration**, page 54.

Serial

My serial device does not function.

The extender supports serial devices at data rates not exceeding 19.2K Baud (although 38.4K operation might be possible with certain equipment).

Check the type of flow control used by the device and CPU. The extender supports RTS, CTS, DTR, and DSR. Some systems may require a wiring adapter to transfer RI and DCD.

Attach the device directly to the serial port on the PC and test whether the problem is a PC or extender problem.

Some serial devices cannot be hot-plugged. Try connecting the device to a powered Remote Unit prior to booting the system.

General Questions

Is it possible to use a cable longer than 300m?

It might be possible to use a cable of up to 500m at lower resolutions. However, we do not recommend this and cannot guarantee that it will work.

Can the extender be daisy chained?

In certain circumstances, it is possible to cascade extenders, though we do not recommend doing so. Careful consideration needs to be given to extender setup, and the electrical environment. If you plan to cascade extenders, please contact Technical Support.

Which interconnection cable is best?

The extender will operate with either shielded (STP/FTP) or unshielded (UTP) CATx cable. However, correctly installed shielded cable is preferred, especially in electrically noisy environments, because it resists interference more strongly, limits ground potential differences, and reduces emissions. To benefit from shielded cable the shield connection *must* be maintained from end to end through any intervening patch cables, panels and RJ45 connectors.

Please note that shielded cable is advised in order to maintain regulatory EMC compliance.

Can the extender system be used between buildings?

No. Ground loops could damage the extender system and attached equipment.

Can multiple Local/Remote Units be used by swapping the interconnection cable?

Local Units provide full keyboard and mouse emulation, so it is possible to swap or switch the local-remote interconnection to create a KVM matrix-switch system. Sometimes you may need to reset the keyboard and mouse (by entering the appropriate command) after a swap or switch. Please call Technical Support before deploying such a system.

Can the extender be connected into our network?

Absolutely not. Regardless of the cable similarities, the data signals and voltages used by the extender are different from those used by Ethernet and other types of networks. Connecting the extender to a LAN hub, switch, repeater, or other network device, or exposing it to the signal levels present on network data lines may damage the extender and other devices.

Appendix A: Example Applications

This section illustrates four specific applications using SDBX Extender Units:

- Six dual-monitor consoles with serial and audio (Figure 15).
- Six remote serial touch screens with local access through a KVM switch (Figure 16).
- Information distribution system sharing a single PC at up to six remote locations (Figure 17).
- Extender system with second screen for security monitoring (Figure 18).

For more specific information about these, or any other complex applications, please discuss suitable extension architecture with Technical Support.

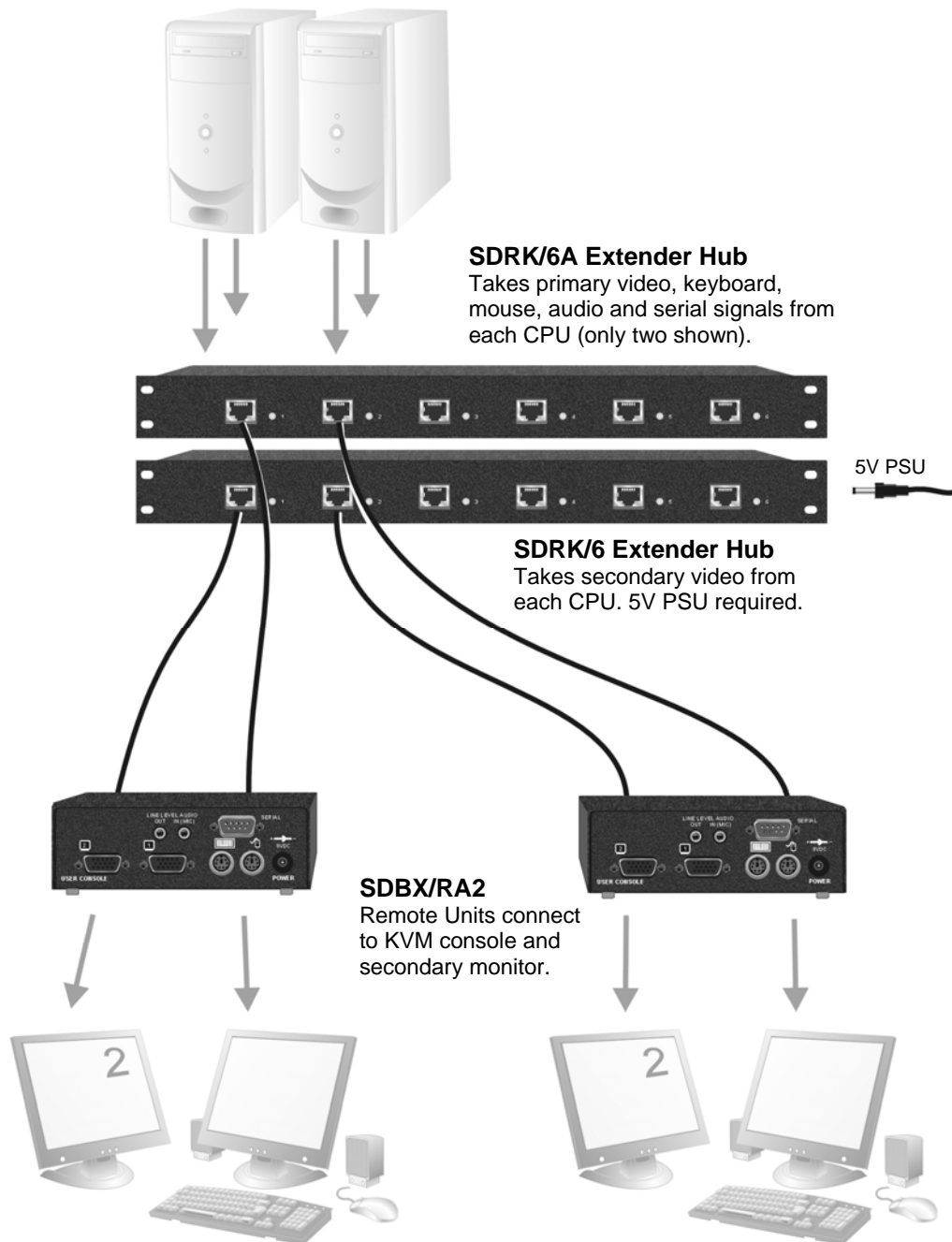

Figure 15 Dual-monitor consoles with serial and audio extension

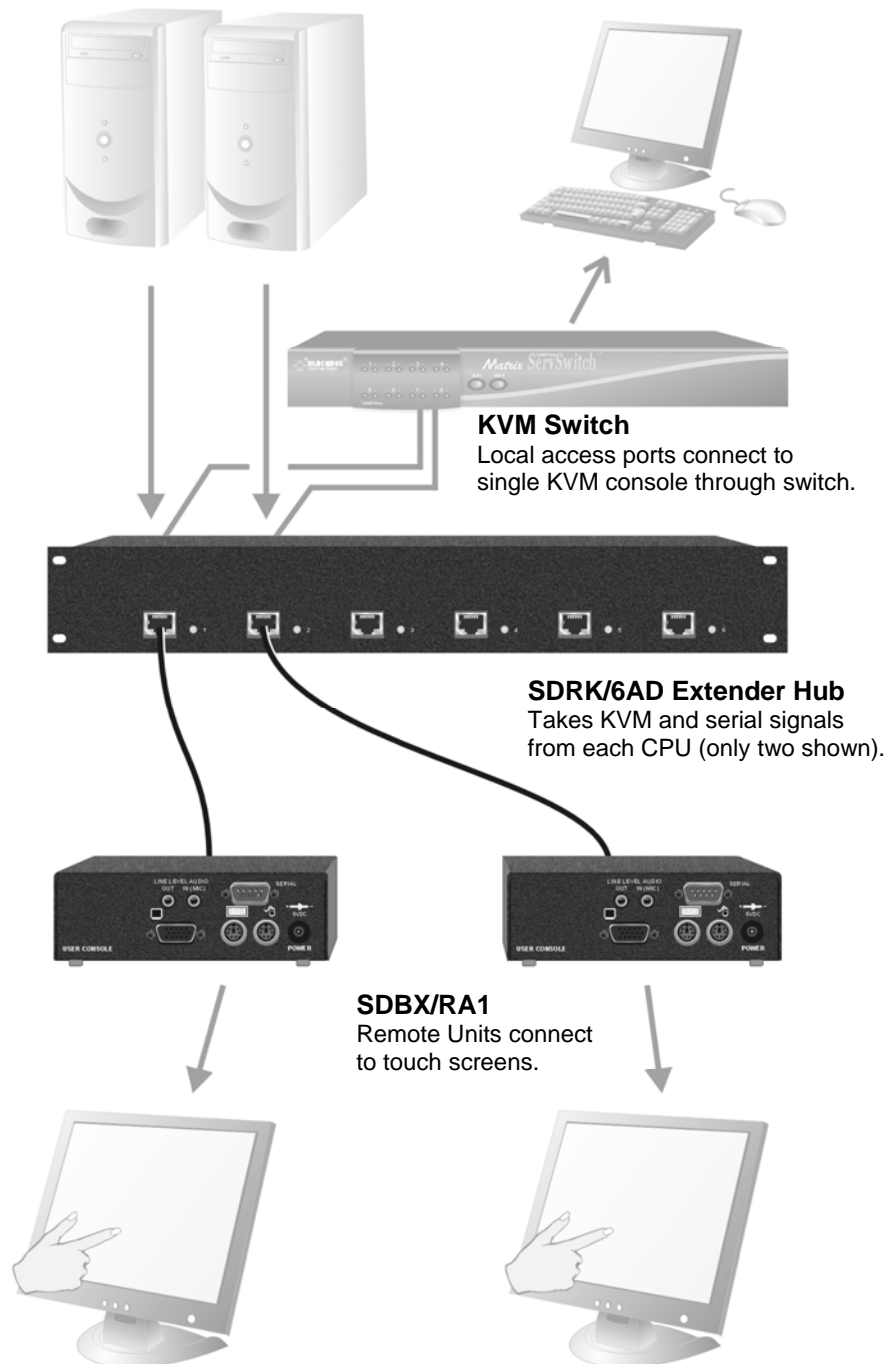

Figure 16 Touch screen network with local access to CPU through KVM switch

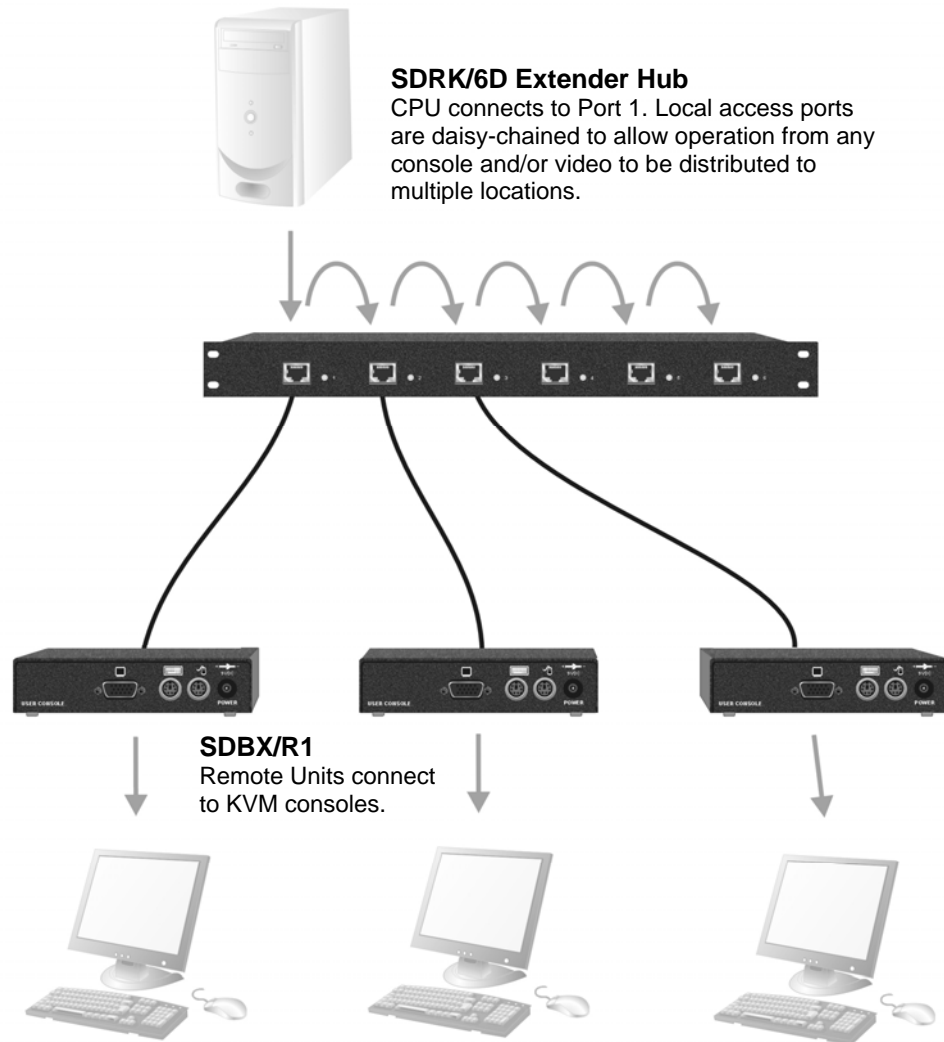

Figure 17 Information distribution system sharing a single PC

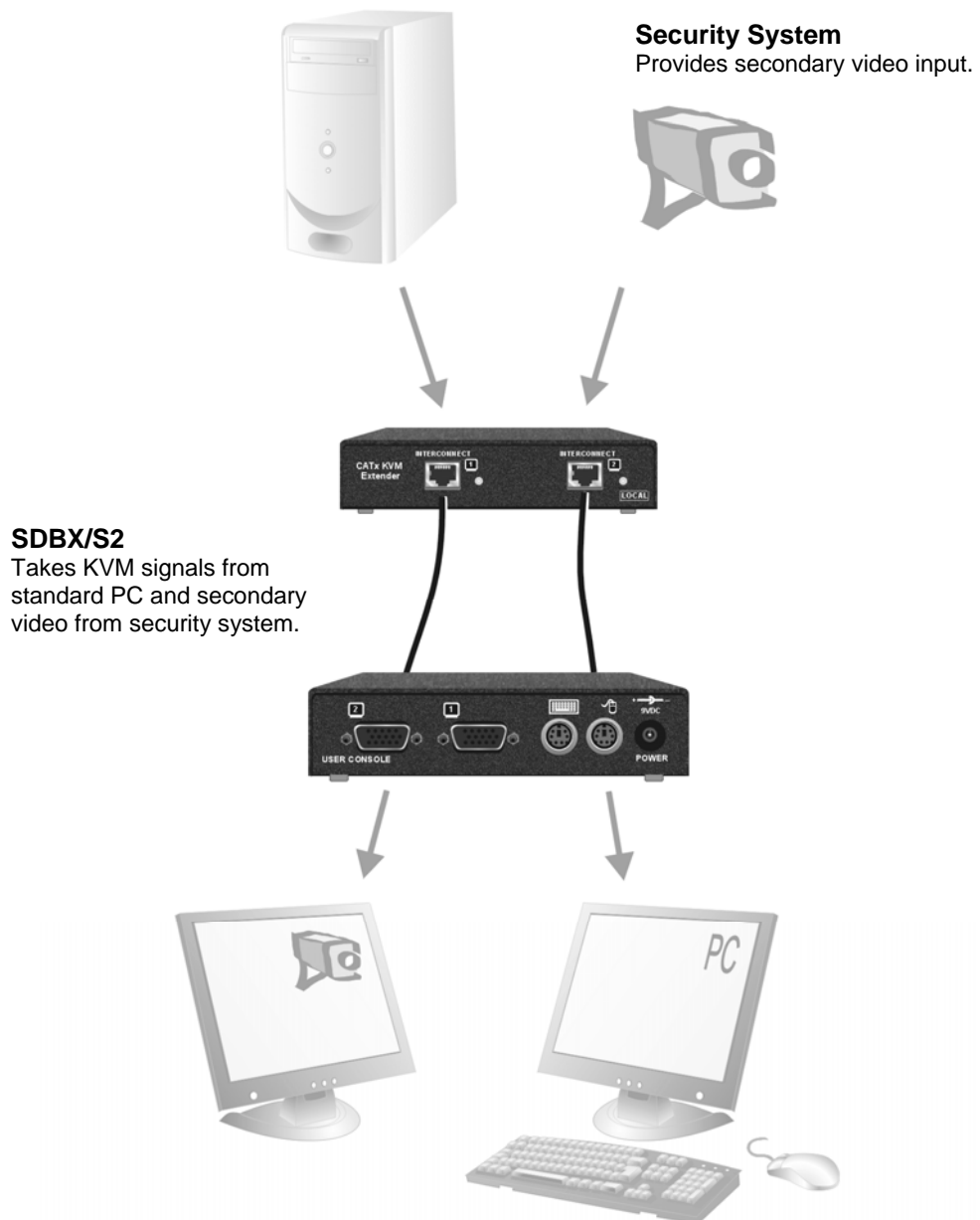

Figure 18 Extender system with second screen for security monitoring

Appendix B: Rack Mount Options

Most of the extender units can be mounted in a 19" rack using one of the two mounting kits:

- SDBR3
- SDBR1

SDBR3 Mounting Kit

SDBR3 allows you to mount up to three of the following units across 1U:

Remote Units:

SDBX/S1	SDBX/D1	SDBX/SA1	SDBX/DA1	SDBX/S2
SDBX/SA2	SDBX/R1	SDBX/R2	SDBX/RA1	SDBX/RA2
SDBX/R4	SDBX/RA4			

Local Units:

SDBX/S2 SDBX/SA2

The kit contains one rack plate and M3 countersunk mounting screws.

To mount a unit:

1. Remove the feet from the extender unit.
2. Align the holes on the base plate with the vacant screw holes on the base of the extender unit.
3. Fasten the base of the unit to the plate of the mounting kit using the supplied screws.

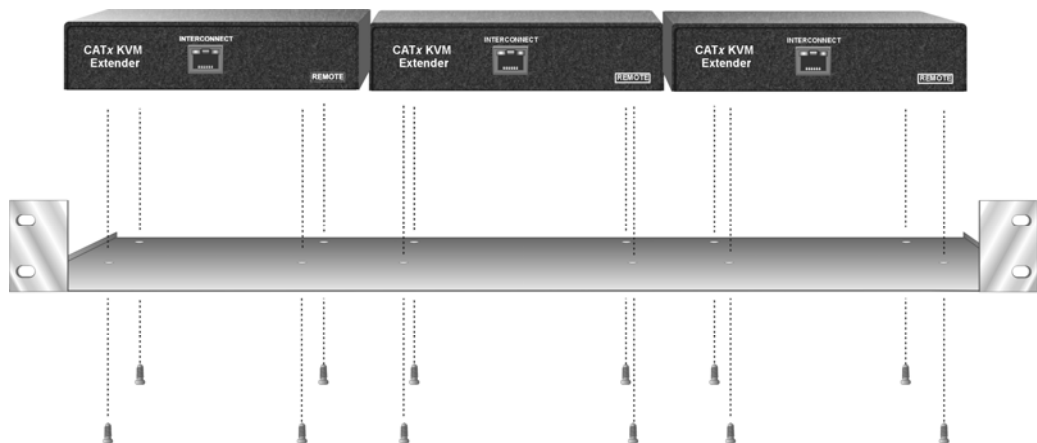

Figure 19 SDBR3 Mounting Kit

SDBR1 Mounting Kit

SDBR1 allows you to mount one of the following Local Units across 1U:

- SDBX/S1
- SDBX/SA1
- SDBX/D1
- SDBX/DA1

The kit consists of two angled brackets.

To mount a unit:

1. Remove the two screws from one side of the unit.
2. Match up the lower pair of holes on a bracket with the vacant screw holes on the side of the unit.
3. Using the original screws, fasten the mounting brackets to the side of the unit.
4. Repeat this procedure on the other side of the unit.
5. Fasten the assembly to the rack unit.

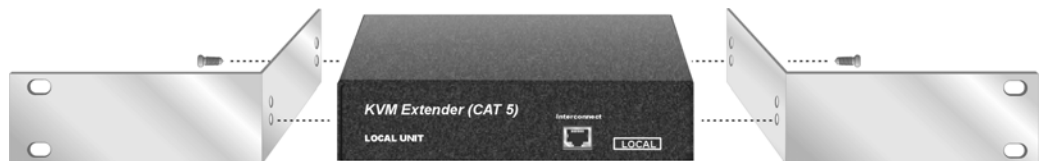

Figure 20 SDBR1 Mounting Kit

Appendix C: Remote Unit: Flash Upgrading & External Configuration

The SDBX Remote Unit contains a service port accessed through the mouse port. By attaching an upgrade cable between this port and the serial port on any PC (or laptop), the Remote Unit's firmware may be upgraded. In addition, all configuration settings may be saved, adjusted and restored. This could be useful in large system roll-outs where similar length cables are used (by avoiding the need to fully set up each Remote Unit individually).

To operate the configuration port, you need:

- A laptop or PC close to the Remote Unit running Windows. The Remote Unit only has to be powered and does not need to be connected to the Local Unit.
- An upgrade cable connected between the mouse port and the laptop or PC's serial port (Part No: SDBX/UC2).
- A software utility called 'ConfigXt'.
- The firmware upgrade file.

The application, detailed instructions and firmware upgrades may be downloaded online. Please consult technical support for details on how to do this.



SDBX Local Units covered by this User Guide are not flash-upgradeable.

Appendix D: Advanced Cabling Issues (Skew)

The suggestions made in this Appendix should only be investigated if you cannot obtain satisfactory image quality after configuring the Remote Unit (as described in Section 3). The techniques described here are usually only necessary when you are operating at the highest screen resolution (1600x1200) with long Interconnect cables.

Dealing with Severe Skew

The SDBX KVM extender provides a maximum skew compensation of 42nS. This is more than adequate for most cables. However, it may not be enough if a particularly long cable is used that exhibits severe delay skew. In this case, some of the procedures described below should be considered. In extreme cases, you should consider using an additional external delay line (Model: SDLY1) or an alternative CATx cable as recommended by Technical Support.

Green Delay

Introducing delays in the video signals inevitably may cause some distortion at the highest screen resolutions (1600x1200). For example, it may result in pixels being sampled twice on TFT screens.

The human eye is extremely sensitive to green distortion. To obtain optimal video performance it is best to ensure that no green delay is required. You can visually check the relative pair delays by viewing the test card (without any delays applied). The two color bars on the left require delaying, but the color bar on the right requires zero delay (slowest) and is the reference. Ideally, green should be the reference signal.

 *If your system requires a large delay on the green signal, try using a crossover patch cable at each end of the link (instead of straight patch cables to connect to wall outlets). In many cases, the crossover should transfer the delay requirement to the blue signal rather than green. The human eye is much less sensitive to blue distortion and so video quality can be improved. Check the result using the test card and adjust the delays accordingly. The main cable should be wired according to EIA-568B as shown below.*

Cable Pinning/Pairing

The following table illustrates which RJ45 connector pins the extenders use for various signals. It also details the standard EIA-568B wiring scheme that is recommended for most installations.

Looking into the RJ45 socket on a *SDBX Remote Unit*, Pin 1 is on the right and Pin 8 on the left.

<i>Pin</i>	<i>Color (EIA-568B)</i>	<i>Signal</i>
1 2	White/Orange Orange/White	Blue Video
3 6	White/Green Green/White	Green Video
4 5	Blue/White White/Blue	Red Video
7 8	White/Brown Brown/White	Data

Using a crossover cable (at each end) will put the green video on the orange colored pair and the blue video on the green colored pair.



EIA-568A wiring can also be used. Contact Technical Support for details.

Optimizing Pairs (General Solution)

Measure pair lengths with a LAN cabling tester (TDR) or view pairs by stripping back a small piece of cable and viewing how tightly pairs are twisted. The most tightly twisted pair is the slowest (longest) and the loosest pair the fastest (shortest). You can also check the relative delays using the test card as described on page 24.

The table below shows the general solution for optimizing CATx cabling for video in order of pair length.

<i>Pins</i>	<i>Pair</i>	<i>Signal</i>
7 & 8	Shortest Pair	Data
1 & 2	3 rd Longest Pair	Blue Video
4 & 5	2 nd Longest Pair	Red Video
3 & 6	Longest Pair	Green Video

Some cables have a '3+1' construction where three pairs closely match. The fourth pair should be used for data and the other pairs sorted as in the above table.

Other cables have a '2+2' construction where there are two sets of dissimilar pairs. Put red and green on one set (tightest) and blue & data on the other.

A suitable pair-swapping scheme is easily made using custom wired patch cables at each end.

Appendix E: Audio/Serial Ports: Operation & Multi-Port Configuration

This appendix details audio & serial interface operation for those models that have this feature:

- SDBX/SA1
- SDBX/DA1
- SDBX/SA2
- SDBX/RA1
- SDBX/RA2
- SDBX/RA4

These extender products contain daughter boards that allow bi-directional stereo audio and a full-duplex serial data link to be sent across the CATx interconnection cable in addition to PS/2 keyboard, mouse and video.

Serial Interface - Set Up and Operation

No setting up or user adjustments are required. Please note that on dual access Local Units, the serial link is always active.

The Remote Unit's serial port is wired as DTE - the same as that on a PC. To connect a serial printer or other DTE (rather than DCE device) to the Remote Unit, you will need a Null-Modem crossover cable between the Remote Unit and the printer. Select Xon/Xoff software flow control on the printer and PC. A serial touch screen may be plugged directly into the Remote Unit.

Serial Interface – Handling Multiple Serial Devices

The extender's serial interface transmits/receives six signals (3 signals in each direction).

Normally, four of these signals are used for hardware handshaking (in addition to TX & RX). However, because each handshaking line can support signals up to 19,200 Baud it is possible to configure the serial interface to handle up to three simple 2-wire (Tx/Rx only) serial links.

To do this, you will need to construct a custom breakout cable. Please contact Technical Support for further information.

Audio Interface - Set Up and Operation

The audio interface is line-level and is designed to take the output from a sound card (or other line-level) source and be connected to a set of powered speakers at the other end of the link.

Stereo audio may be transmitted either way across the link (simultaneously).

No setup is required unless a microphone is connected to the Remote Unit.

Connect the extender as follows:

- Take the line-level output from your sound card (green connector) and connect to 'Line In' on the Local Unit.
- Connect 'Line Out' on the Remote Unit to a set of powered speakers.

Audio Interface – Using a Microphone

A microphone may be plugged into the 'Line In' connector on the Remote Unit.

There are two ways of setting up a microphone:

- The Local Unit's 'Line Out' connection should normally be wired to the microphone input (Pink) on your sound card. The sound card should then be set up to provide additional amplification (+17dB). This is the preferred connection method.
- Alternatively, the Remote Unit itself can provide microphone amplification. To set this, open up the Remote Unit and locate the jumper labeled 'MIC' on the daughter board. Connect this jumper across the pins. The Local Unit's 'Line Out' connection should then be wired to 'Line In' (Blue) on your sound card.

If your microphone is already amplified, follow the second method but **DO NOT** install the amplification jumper in the Remote Unit.

Appendix F: Obtaining Technical Support

If you have any problems or questions, contact your dealer for technical support.

To enable us to provide efficient and effective support, please make a note of the following information before you call:

- The KVM extender's firmware revision level. This is printed on the base of both the Local and Remote Units:

Version Number Format: *xxSyy/zz*

xx is the hardware revision number

yy is the firmware revision number

zz is the auxiliary revision number

- The nature and duration of the problem and when it occurs.
- The components involved in the problem including manufacturer and model numbers.
- Results from any testing you have done.

If you need to return a unit for repair, please package carefully, preferably using the original box. Include everything you received with the unit. Before returning, contact Technical Support to get a Return Authorization (RA) number.



Do not attempt to repair the units. The KVM extender set contains no user-serviceable parts.

Appendix G: Specifications

Video

Maximum Resolution	1600x1200@60Hz over 200m 1280x1024@75Hz over 300m Operation at higher resolutions/refresh rates may be possible at shorter distances
Video Compatibility	VGA to UXGA, RGB
Video I/O	0.7V P-P
Skew Compensation	15-stage. 42nS Max. 2.8nS per step Compensation available on each color
Video Compensation	2-stage. Separate LF & HF Equalizers
Video Coupling	DC
Sync I/O	Separate/Composite TTL Level Sync on green Sync Polarity is preserved
Video Input Connectors	HD15 (Male) on Single-Head Local Units DB25 (Female) on Dual-Head Local Units (KVM)
Video Output Connectors	HD15 (Female)

Keyboard and Mouse

KB Compatibility	PC/AT, PS/2
Mouse Compatibility	Standard PS/2 two/three button Standard wheel mice Logitech 3-button PS/2
KB/Mouse Connectors (CPU)	6-Pin MiniDIN Socket (Single-Head Local) DB25 (Female) on Dual-Head Local Units (KVM)
KB/Mouse Connectors (Device)	6-Pin MiniDIN Socket

Serial Interface

<i>Max Baud Rate Supported</i>	19.2K Baud
<i>Serial Data Format</i>	Transparent
<i>Signals Transferred</i>	TX, RX, RTS, CTS, DTR, DSR
<i>Local Unit Connector</i>	DB9 Female (DCE)
<i>Remote Unit Connector</i>	DB9 Male (DTE)

Audio Interface

<i>Description</i>	Bi-directional stereo audio link
<i>Transmission method</i>	Digitized virtually CD quality audio (16-bit, 38.4kHz)
<i>Signal levels</i>	Line level (4 Volts Pk-Pk maximum)
<i>Input Impedance</i>	47k Ω
<i>Local Unit Connectors</i>	2x3.5mm stereo jack socket (Line In & Line Out)
<i>Remote Unit connectors</i>	2x3.5mm stereo jack socket (Line/Mic In & Line Out)
<i>Microphone Support</i>	Microphone may be connected to Remote Unit Pullup resistor provides bias for condenser microphone Option to set microphone amplification to +17dB

Power Requirements

<i>Local Unit</i>	5V at up to 200mA supplied by PCs PS/2 keyboard port. External PSU may also be connected
<i>Remote Power Supply</i>	9V, 2A (18W) Regulated (certified to all relevant safety standards) Universal IEC Input Isolated Output 2.5mm DC Jack (Center Positive)

Size and Shipping Weight

<i>SDBX/R1, SDBX/R2</i>	Remote Unit: 143x145x29mm Shipping Weight: 1.03 Kg
<i>SDBX/RA1</i>	Remote Unit: 143x145x44mm (1U) Shipping Weight: 1.09 Kg
<i>SDBX/RA2</i>	Remote Unit: 143x145x44mm (1U) Shipping Weight: 1.16 Kg
<i>SDBX/S2</i>	Local Unit: 146x114x29mm Remote Unit: 143x145x29mm Shipping Weight: 2.13 Kg
<i>SDBX/SA2</i>	Local Unit: 146x114x44mm (1U) Remote Unit: 143x145x44mm (1U) Shipping Weight: 2.58 Kg
<i>SDBX/S1</i>	Local Unit: 202x100x36mm Remote Unit: 143x145x29mm Shipping Weight: 2.10 Kg
<i>SDBX/D1</i>	Local Unit: 202x100x36mm Remote Unit: 143x145x29mm Shipping Weight: 2.15 Kg
<i>SDBX/SA1</i>	Local Unit: 202 x100x44mm (1U) Remote Unit: 143x145x44mm (1U) Shipping Weight: 2.48 Kg
<i>SDBX/DA1</i>	Local Unit: 202 x100x44mm (1U) Remote Unit: 143x145x44mm (1U) Shipping Weight: 2.53 Kg
<i>SDBX/R4</i>	Remote Unit: 279x145x29mm Shipping Weight: 1.66 Kg
<i>SDBX/RA4</i>	Remote Unit: 279x145x29mm Shipping Weight: 1.68 Kg

Environmental

<i>Operating Temperature</i>	0 to 40 °C
<i>Storage Temperature</i>	-30 to 65 °C
<i>Relative Humidity</i>	5-90% non-condensing
<i>Chassis Construction</i>	Fully shielded. Black painted steel

Appendix H: EU Regulatory Compliance

WARNING!

This is a class A product. In a domestic environment, this product may cause radio interference in which case the user may be required to take adequate measures.

This product complies with the following harmonized standards for Information Technology Equipment: EN55022:2006 (Class A), EN55024:1998 + A1:2001 + A2:2003.

To maintain compliance the use of correctly installed shielded (STP/FTP) interconnection cable is advised. Only use CPU cables and power supplies provided (or recommended) for use with this product.

When used in environments that have high levels of electromagnetic interference or excessive power ground noise, you may experience disturbances to video and/or data transmission. If this is the case, please refer to the Troubleshooting section of the User Guide for further information, or contact Technical Support. In electrically noisy environments, the use of shielded (STP/FTP) rather than unshielded (UTP) interconnection cable is recommended.



Appendix I: North American Regulatory Compliance

This equipment has been found to comply with the limits for a Class A digital device, pursuant to Part 15 of the FCC Rules. These limits are designed to provide reasonable protection against harmful interference when the equipment is operated in a commercial environment. This equipment generates, uses, and can radiate radio frequency energy and, if not installed and used in accordance with the instruction manual, may cause harmful interference to radio communications. Operation of this equipment in a residential area is likely to cause harmful interference in which case the user will be required to correct the interference at his own expense.

Changes or modifications not expressly approved by the party responsible for compliance could void the user's authority to operate the equipment.

Shielded cables must be used with this equipment to maintain compliance with radio frequency energy emission regulations and ensure a suitably high level of immunity to electromagnetic disturbances.

All power supplies are certified to the relevant major international safety standards.

Appendix J: Disclaimer

While every precaution has been taken in the preparation of this manual, the manufacturer assumes no responsibility for errors or omissions. Neither does the manufacturer assume any liability for damages resulting from the use of the information contained herein. The manufacturer reserves the right to change the specifications, functions, or circuitry of the product without notice.

The manufacturer cannot accept liability for damage due to misuse of the product or due to any other circumstances outside the manufacturer's control (whether environmental or installation related). The manufacturer shall not be responsible for any loss, damage, or injury arising directly, indirectly, or consequently from the use of this product.